



**Marlborough Lines Limited**  
**Asset Management Plan**  
1 April 2015 to 31 March 2025

## Document Control

|            |   |
|------------|---|
| File Path: | X:\Engineering\Asset Management\2015\AMP documents\for KJF edit\AMP 2015 Draft V10.docx |
| Status:    | Issue I   |

## Version Control

| Version | Date          | Comments   |
|---------|---------------|------------|
| Draft   | 18 Feb 2015   | For review |
| I       | 27 March 2015 | Edited     |
|         |               |            |
|         |               |            |

## Summary

Welcome to Marlborough Lines Limited's (MLL) Asset Management Plan (AMP) for the planning period 1<sup>st</sup> April 2015 to 31<sup>st</sup> March 2025.

Electricity is an important component of modern society. The safe, secure, and reliable delivery of electricity is essential to our way of life, our homes and our businesses. Electricity provides energy for heating, lighting, appliances, computers, transport and industry. The effective management of Marlborough Lines distribution system together with staff, contractors and all resources is important to all stakeholders.

This AMP forms the backbone of Marlborough Lines asset management process and documents the assets, their condition, service levels, network development planning, lifecycle planning, risk management, and asset performance.

Key features of this asset management plan are:

- Reliability performance is very good on a comparative basis to other Networks given the type and length of Network.
- Assets with a Regulatory Asset Base value of \$215 million which are generally in good condition.
- Improvements in service targets and performance and the inclusion of targets and performance data on an area basis (urban, rural, and sounds)
- 1.5% load growth used for planning purposes, this assumes that the economy will improve slightly and growth will return to levels consistent with the historical levels.
- Forecast Capital Expenditure of \$12.5 million and Opex of \$11.8 million for 2016. Continued investment in asset renewal, Network automation and a strong focus on vegetation management.
- Risk profile essentially unchanged from the past, however some discussion and commentary on the risks of high impact, low probability events included, i.e. Earthquake/Tsunami, major storm damage, loss of GXP or transmission, major fire events.
- The AMMAT (Asset Management Maturity Assessment ) shows that MLL's asset management process and systems are consistent with the size and type of organisation and helps to identify possible areas for improvement.
- Details of proposed work and expenditure levels are given for the next ten years in sections 5 and 6. These are at levels consistent with current workload and therefore MLL has the capacity to deliver these work programmes.

# Table of Contents

|   |           |
|---|-----------|
| <b>1. BACKGROUND AND OBJECTIVES OF THE AMP</b> .....                    | <b>10</b> |
| 1.1 PURPOSE STATEMENT .....   | 11        |
| 1.2 STRATEGIC PLANNING DOCUMENTS .....                                  | 12        |
| 1.2.1 <i>Vision</i> .....   | 12        |
| 1.2.2 <i>Mission</i> .....  | 12        |
| 1.3 STATEMENT OF CORPORATE INTENT .....                                 | 13        |
| 1.4 INTERACTION BETWEEN PLANNING DOCUMENTS .....                        | 13        |
| 1.5 PLANNING PERIOD .....   | 15        |
| 1.6 DATE APPROVED BY DIRECTORS .....                                    | 15        |
| 1.7 DESCRIPTION OF STAKEHOLDER INTERESTS .....                          | 15        |
| 1.7.1 <i>Managing Conflicting Interests</i> .....                       | 21        |
| 1.8 ACCOUNTABILITIES & RESPONSIBILITIES FOR ASSET MANAGEMENT .....      | 21        |
| 1.8.1 <i>Accountability at Ownership Level</i> .....                    | 22        |
| 1.8.2 <i>Accountability at Governance Level</i> .....                   | 23        |
| 1.8.3 <i>Board Reporting</i> .....                                      | 23        |
| 1.8.4 <i>Accountability at Managing Director Level</i> .....            | 24        |
| 1.8.5 <i>Accountability at Management Level</i> .....                   | 24        |
| 1.8.6 <i>Accountability at Works Implementation Level</i> .....         | 24        |
| 1.9 SIGNIFICANT ASSUMPTIONS .....                                       | 26        |
| 1.10 FACTORS THAT MAY LEAD TO MATERIAL DIFFERENCES .....                | 27        |
| 1.11 OVERARCHING ASSET STRATEGY .....                                   | 28        |
| 1.11.1 <i>Asset Management Policy</i> .....                             | 28        |
| 1.11.2 <i>Service levels</i> .....                                      | 29        |
| 1.11.3 <i>Asset configuration</i> .....                                 | 29        |
| 1.11.4 <i>Resourcing</i> .....  | 30        |
| 1.11.5 <i>Materials</i> .....   | 30        |
| 1.11.6 <i>Risk</i> .....  | 31        |
| 1.12 OVERVIEW OF SYSTEMS AND INFORMATION .....                          | 32        |
| 1.13 LIMITATIONS OF ASSET MANAGEMENT DATA .....                         | 35        |
| 1.14 DESCRIPTION OF KEY PROCESSES .....                                 | 36        |
| 1.14.1 <i>Processes for inspections and maintenance</i> .....           | 36        |
| 1.14.2 <i>Processes for development projects</i> .....                  | 36        |
| 1.14.3 <i>Processes for performance measurement</i> .....               | 37        |
| 1.14.4 <i>Wider processes, information resources and software</i> ..... | 37        |
| 1.14.5 <i>Asset and Works Management Software</i> .....                 | 38        |
| 1.14.6 <i>Key Information Locations</i> .....                           | 39        |
| 1.14.7 <i>Databases</i> .....   | 40        |
| 1.15 OVERVIEW OF DOCUMENTATION, CONTROLS AND REVIEW PROCESS .....       | 41        |
| <b>2. ASSETS COVERED</b> .....  | <b>42</b> |
| 2.1 DETAILS OF ASSETS .....   | 42        |
| 2.1.1 <i>Background</i> .....   | 42        |
| 2.1.2 <i>Load Characteristics</i> .....                                 | 43        |
| 2.1.3 <i>Large Customers</i> .....                                      | 43        |
| 2.1.4 <i>Supply Area Characteristics</i> .....                          | 44        |
| 2.2 DEMOGRAPHICS .....  | 48        |
| 2.3 KEY ECONOMIC ACTIVITIES .....                                       | 48        |
| 2.4 OTHER DRIVERS OF ELECTRICITY USE .....                              | 50        |
| 2.4.1 <i>Disruptive Technologies</i> .....                              | 50        |
| 2.5 DESCRIPTION OF NETWORK CONFIGURATION .....                          | 51        |
| 2.5.1 <i>Overview</i> .....   | 51        |
| 2.5.2 <i>Transpower Point of Supply/Transmission Lines</i> .....        | 51        |
| 2.5.3 <i>Embedded Generation</i> .....                                  | 52        |
| 2.5.4 <i>Sub-transmission System</i> .....                              | 53        |

|           |   |            |
|-----------|---|------------|
| 2.5.5     | Zone Substations .....                                | 55         |
| 2.5.6     | 2014 Zone Substation Loadings.....                    | 56         |
| 2.5.7     | Distribution System .....                             | 57         |
| 2.5.8     | Distribution Substations .....                        | 57         |
| 2.5.9     | Low Voltage Network .....                             | 57         |
| 2.5.10    | Ripple Control, SCADA and Communications .....        | 57         |
| 2.6       | ASSET CATEGORIES.....                                 | 59         |
| 2.6.1     | Major Asset Groups .....                              | 59         |
| 2.6.2     | Asset Lives .....                                     | 59         |
| 2.6.3     | Poles .....   | 60         |
| 2.6.4     | Bulk Supply Points.....                               | 62         |
| 2.6.5     | Sub-transmission Network.....                         | 63         |
| 2.6.6     | 33/11kV Zone Substation Transformers .....            | 64         |
| 2.6.7     | Distribution Network .....                            | 69         |
| 2.6.8     | Distribution Substations .....                        | 72         |
| 2.6.9     | Distribution Switchgear .....                         | 75         |
| 2.6.10    | Low Voltage Network.....                              | 77         |
| 2.6.11    | Ripple Injection.....                                 | 78         |
| 2.6.12    | Automation and Communication Assets .....             | 79         |
| 2.6.13    | Metering.....   | 81         |
| 2.6.14    | Power Factor Correction .....                         | 81         |
| 2.6.15    | Mobile Substations/Generators .....                   | 81         |
| 2.6.16    | Control Room .....                                    | 82         |
| 2.6.17    | Justification for Assets.....                         | 82         |
| <b>3.</b> | <b>SERVICE LEVELS .....</b>                           | <b>84</b>  |
| 3.1       | DEFINED PERFORMANCE INDICATORS .....                  | 84         |
| 3.2       | CUSTOMER-ORIENTED PERFORMANCE INDICATORS .....        | 85         |
| 3.2.1     | Response times .....                                  | 85         |
| 3.3       | DETAILED SERVICE TARGETS .....                        | 86         |
| 3.4       | ASSET PERFORMANCE INDICATORS .....                    | 88         |
| 3.4.1     | Justification for Targets .....                       | 89         |
| 3.5       | BASIS OF PERFORMANCE INDICATORS .....                 | 89         |
| 3.5.1     | Changes to Performance Indicators .....               | 90         |
| <b>4.</b> | <b>NETWORK DEVELOPMENT PLANNING .....</b>             | <b>91</b>  |
| 4.1       | PLANNING CRITERIA AND ASSUMPTIONS .....               | 91         |
| 4.2       | TRIGGER POINTS FOR PLANNING PURPOSES .....            | 92         |
| 4.3       | STRATEGIES FOR STANDARDISING ASSETS AND DESIGNS.....  | 93         |
| 4.4       | STRATEGIES FOR ENERGY EFFICIENCY .....                | 93         |
| 4.5       | DETERMINING CAPACITY.....                             | 93         |
| 4.6       | PRIORITISING NETWORK DEVELOPMENT PROJECTS.....        | 94         |
| 4.7       | DEMAND FORECASTS .....                                | 95         |
| 4.8       | ZONE SUBSTATION DEMAND FORECASTS .....                | 100        |
| 4.9       | SIGNIFICANT DEVELOPMENT OPTIONS AVAILABLE.....        | 101        |
| 4.10      | ISSUES AFFECTING DEVELOPMENT OPTIONS .....            | 103        |
| 4.11      | EMBEDDED GENERATION POLICIES.....                     | 104        |
| 4.12      | NON-NETWORK SOLUTIONS .....                           | 105        |
| <b>5.</b> | <b>CAPITAL EXPENDITURE .....</b>                      | <b>106</b> |
| 5.1       | NETWORK CAPITAL EXPENDITURE BUDGET 2015 TO 2025 ..... | 107        |
| 5.2       | NETWORK CAPITAL EXPENDITURE PROGRAMME 2016 .....      | 108        |
| 5.3       | CONSUMER CONNECTION.....                              | 108        |
| 5.4       | SYSTEM GROWTH .....                                   | 108        |
| 5.5       | ASSET REPLACEMENT AND RENEWAL .....                   | 109        |
| 5.5.1     | Subtransmission .....                                 | 109        |
| 5.5.2     | Distribution and LV Lines .....                       | 110        |

|        |  |            |
|--------|--|------------|
| 5.5.3  | <i>Distribution and LV Cables</i> .....                      | 111        |
| 5.5.4  | <i>Distribution substations and transformers</i> .....       | 112        |
| 5.5.5  | <i>Distribution switchgear</i> .....                         | 112        |
| 5.6    | ASSET RELOCATIONS.....                                       | 112        |
| 5.6.1  | <i>Roading authority relocations</i> .....                   | 112        |
| 5.6.2  | <i>Forestry relocations</i> .....                            | 112        |
| 5.6.3  | <i>Underground Conversions</i> .....                         | 113        |
| 5.7    | QUALITY OF SUPPLY .....                                      | 113        |
| 5.7.1  | <i>SCADA</i> .....   | 114        |
| 5.7.2  | <i>Network Automation</i> .....                              | 115        |
| 5.7.3  | <i>Alternative Supplies</i> .....                            | 116        |
| 5.8    | LEGISLATIVE AND REGULATORY.....                              | 117        |
| 5.9    | OTHER RELIABILITY , SAFETY AND ENVIRONMENT .....             | 117        |
| 5.9.1  | <i>Substation Earthing</i> .....                             | 118        |
| 5.9.2  | <i>SWER Re-insulation</i> .....                              | 118        |
| 5.9.3  | <i>Tee Joint Removal</i> .....                               | 118        |
| 5.10   | NON NETWORK.....   | 118        |
|        | <b>6. LIFECYCLE PLANNING .....</b>                           | <b>119</b> |
| 6.1    | KEY DRIVERS.....   | 119        |
| 6.2    | KEY ASSUMPTIONS.....   | 120        |
| 6.3    | ASSET REPLACEMENT AND RENEWAL POLICIES.....                  | 120        |
| 6.4    | ROUTINE & CORRECTIVE MAINTENANCE & INSPECTION POLICIES ..... | 121        |
| 6.5    | SYSTEMIC FAILURE IDENTIFICATION .....                        | 123        |
| 6.6    | TESTING AND INSPECTION REGIMES.....                          | 123        |
| 6.6.1  | <i>Zone Substation and Regulator Site Inspections</i> .....  | 123        |
| 6.6.2  | <i>Major Distribution and Substation Inspections</i> .....   | 123        |
| 6.6.3  | <i>Ground Mount Switch Inspections</i> .....                 | 124        |
| 6.6.4  | <i>Pole Mounted Circuit Breaker Inspections</i> .....        | 124        |
| 6.6.5  | <i>Earth Testing</i> .....                                   | 124        |
| 6.6.6  | <i>Asset Condition Survey (Overhead Lines)</i> .....         | 125        |
| 6.6.7  | <i>MDI Readings</i> .....                                    | 125        |
| 6.6.8  | <i>Safety Inspections</i> .....                              | 125        |
| 6.6.9  | <i>Public Places Inspections</i> .....                       | 125        |
| 6.6.10 | <i>Road and Rail Crossings</i> .....                         | 125        |
| 6.6.11 | <i>Thermovision Surveys</i> .....                            | 126        |
| 6.6.12 | <i>Partial Discharge (PD) Surveys</i> .....                  | 126        |
| 6.6.13 | <i>DGA Testing</i> .....                                     | 126        |
| 6.6.14 | <i>Trees</i> .....   | 126        |
| 6.6.15 | <i>Diesel Generator Inspections</i> .....                    | 127        |
| 6.7    | OPERATIONAL EXPENDITURE .....                                | 127        |
| 6.8    | RENEWAL EXPENDITURE.....                                     | 130        |
|        | <b>7. RISK MANAGEMENT .....</b>                              | <b>131</b> |
| 7.1    | MLL RISK INTRODUCTION .....                                  | 131        |
| 7.2    | RISK CONTEXT .....   | 132        |
| 7.3    | RISK MANAGEMENT TOOLS .....                                  | 134        |
| 7.3.1  | <i>Central Risk Register</i> .....                           | 134        |
| 7.3.2  | <i>Risk Categories</i> .....                                 | 134        |
| 7.3.3  | <i>Risk Register</i> .....                                   | 135        |
| 7.3.4  | <i>Risk Treatments and Initiatives</i> .....                 | 136        |
| 7.3.5  | <i>Treated Risk Matrix</i> .....                             | 140        |
| 7.3.6  | <i>Highest Rated Risks</i> .....                             | 141        |
| 7.3.7  | <i>General Risk Commentary</i> .....                         | 142        |
| 7.4    | HIGH IMPACT, LOW PROBABILITY EVENTS .....                    | 143        |
| 7.5    | EMERGENCY RESPONSE PLANS .....                               | 144        |

|  |            |
|--|------------|
| <b>8. RISK REGISTER .....</b>                            | <b>145</b> |
| <b>9. PERFORMANCE EVALUATION .....</b>                   | <b>161</b> |
| 9.1 COMPARATIVE ASSESSMENT .....                         | 161        |
| 9.1.1 <i>Operational Expenditure (Opex)</i> .....        | 162        |
| 9.1.2 <i>Capital Expenditure (Capex)</i> .....           | 166        |
| 9.1.3 <i>Regulatory Asset Base (RAB)</i> .....           | 169        |
| 9.1.4 <i>Network Reliability</i> .....                   | 172        |
| 9.1.5 <i>Comparative Technical Performance</i> .....     | 177        |
| 9.2 PERFORMANCE AGAINST SERVICE LEVEL TARGETS.....       | 180        |
| 9.2.1 <i>Customer Satisfaction by Survey</i> .....       | 180        |
| 9.2.2 <i>Network Performance – Planned Outages</i> ..... | 181        |
| 9.2.3 <i>Network Performance – Forced Outages</i> .....  | 183        |
| 9.2.4 <i>Network Outages Analysis</i> .....              | 186        |
| 9.2.5 <i>Technical Efficiency</i> .....                  | 190        |
| 9.3 FINANCIAL PERFORMANCE COMPARED TO PLAN .....         | 191        |
| 9.4 SUMMARY OF AMMAT ASSESSMENT.....                     | 192        |
| 9.5 PERFORMANCE EVALUATION AND INITIATIVES .....         | 192        |
| <b>10. CAPABILITY TO DELIVER.....</b>                    | <b>194</b> |
| 10.1 CONFIRMATION AMP CAN BE DELIVERED .....             | 194        |
| 10.2 ORGANISATIONAL STRUCTURE .....                      | 194        |

## Appendices

|   |            |
|---|------------|
| <b>A- Risk Register.....</b>                          | <b>A2</b>  |
| <b>B - Asset Renewal Performance Evaluation .....</b> | <b>A14</b> |
| <b>C - Disclosure Schedules .....</b>                 | <b>A24</b> |
| <b>D - Zone Substation loadings .....</b>             | <b>A59</b> |
| <b>E - General Network Policies .....</b>             | <b>A74</b> |
| <b>F - Single Line Diagrams .....</b>                 | <b>A83</b> |
| <b>G - Liquefaction and Tsunami Zones .....</b>       | <b>A85</b> |
| <b>H - Glossary of Terms.....</b>                     | <b>A87</b> |
| <b>I - Reader Survey Form .....</b>                   | <b>A89</b> |

## List of Figures

|  |    |
|--|----|
| Figure 1 - Electricity Industry Structure.....                 | 10 |
| Figure 2 – Interaction between Major Planning Documents.....   | 13 |
| Figure 3 – Stakeholders .....                                  | 16 |
| Figure 4 - Accountabilities for Asset Management .....         | 22 |
| Figure 5 – Interaction Between Major Planning Documents .....  | 32 |
| Figure 6 - MLL Network .....                                   | 43 |
| Figure 7 - Central 33kV Sub-transmission .....                 | 54 |
| Figure 8 - 33kV Sub-transmission System.....                   | 54 |
| Figure 9 - Pole Condition .....                                | 62 |
| Figure 10 - Pole Age .....                                     | 62 |
| Figure 11 - 33kV Line Age Profile .....                        | 63 |
| Figure 12 - 33kV Cables Age Profile .....                      | 64 |
| Figure 13 - 11kV Overhead Lines Age Profile .....              | 70 |
| Figure 14 - 11kV Underground Cable Age Profile .....           | 72 |
| Figure 15 – Age Profile for Distribution Transformers.....     | 73 |
| Figure 17 - Number of Transformers Scrapped.....               | 74 |
| Figure 16 – Number of distribution transformers scrapped ..... | 74 |
| Figure 18 - LV Network Age Profile .....                       | 77 |
| Figure 19 – Blenheim Load Duration.....                        | 97 |

|   |     |
|---|-----|
| Figure 20 - Average growth rates for NZ and MLL load .....                        | 98  |
| Figure 21 - Projected Load Growth .....   | 99  |
| <b>Figure 22 – Risk Management Process Overview</b> .....                         | 131 |
| Figure 23 – Summary of risk score reduction .....                                 | 137 |
| Figure 24 - Count of post-treatment risks .....                                   | 140 |
| Figure 25 - Comparison of Opex .....  | 163 |
| Figure 26 - Regression for Direct Opex.....                                       | 164 |
| Figure 27: Regression Expectation for Vegetation Opex .....                       | 165 |
| Figure 28: Expectation for Indirect Opex.....                                     | 166 |
| Figure 29: Expectation for Connections Capex .....                                | 167 |
| Figure 30: Replacement Capex Forecast (blue) and Model (black) .....              | 168 |
| Figure 31: Comparative Composition of RAB.....                                    | 169 |
| Figure 32: Depreciation-based Lives and Consumption of Life .....                 | 170 |
| Figure 33: Regression for Expected RAB .....                                      | 171 |
| Figure 34: Regression for Plan SAIFI.....   | 172 |
| Figure 35: Regression for Normalised Fault SAIFI .....                            | 173 |
| Figure 36: Total Normalised SAIFI Trend .....                                     | 174 |
| Figure 37: Fault Counts by Network Exposure .....                                 | 175 |
| Figure 38: Distribution of CAIDI (all EDBs [bars] + MLL performance [dots]) ..... | 176 |
| Figure 39: CAIDI Trend.....   | 177 |
| Figure 40: Expectation of Network Losses.....                                     | 178 |
| Figure 41: Distribution Transformer Utilisation .....                             | 179 |
| Figure 42 : Planned Outage Performance .....                                      | 182 |
| Figure 43: Unplanned outages performance .....                                    | 185 |
| Figure 44 - Fault Causes.....   | 187 |
| Figure 45: 33kV and 11kV outages split.....                                       | 187 |
| Figure 46: 33 kV outages makeup .....   | 188 |
| Figure 47: 11 kV outages makeup .....   | 189 |
| Figure 48: Asset related faults per annum .....                                   | 190 |

## List of Photographs

|  |            |
|--|------------|
| Photo 1 - Staff undertaking maintenance on 33kV line.....                    | 25         |
| Photo 2 - renewed 33kV Line Lansdowne Park to Riverlands - Steel poles ..... | 27         |
| Photo 3 - Switchgear at Cloudy Bay substation.....                           | 28         |
| Photo 4 - Ward Substation.....   | 31         |
| Photo 5 - testing new recloser, Saddle Hill.....                             | 35         |
| Photo 6 - 11kV line through Trees.....                                       | 41         |
| Photo 7 - Lulworth Wind Generation .....                                     | 52         |
| Photo 8 - Waters Substation, Blenheim .....                                  | 55         |
| Photo 9 SCADA Controlled 11kV recloser.....                                  | 58         |
| Photo 10 – Lineman placing rope from helicopter into pulley line roller..... | 70         |
| Photo 11 – SWER Lines in Tory Channel.....                                   | 71         |
| Photo 12 - - Transformers in Taylor Pass Yard.....                           | 73         |
| Photo 13 - 11kV Transformer at Wind farm site.....                           | 74         |
| Photo 14 - Work on Renewal of Lansdowne to Riverlands 33kV line.....         | 78         |
| Photo 15 – New Control Room at Alfred Street .....                           | 82         |
| Photo 16 – Trimming Vegetation near 11kV line .....                          | 86         |
| Photo 17 – Typical Marlborough Sounds setting .....                          | 87         |
| Photo 18 – Springlands substation, Blenheim .....                            | 91         |
| Photo 19 - Vineyards.....  | 96         |
| <i>Photo 20 – Cloudy Bay Substation.....</i>                                 | <i>106</i> |
| <i>Photo 21 - 33kV line renewal.....</i>                                     | <i>130</i> |

## List of Tables

|   |    |
|---|----|
| Table 1 - Guides to Decision Making.....              | 14 |
| Table 2 – Stakeholder’s Interests .....               | 17 |
| Table 3 - Identification of Expectations.....         | 18 |
| Table 4 - Accommodation of Stakeholder Interests..... | 20 |
| Table 5 – Significant Assumptions .....               | 26 |
| Table 6 – Disclosures/Future Outcomes.....            | 27 |
| Table 7 - Guides to Decision making.....              | 34 |
| Table 8 – Limitations in AMP data .....               | 35 |
| Table 9 - Information Repositories.....               | 40 |



|  |     |
|--|-----|
| Table 10 - AMP Communication .....                               | 41  |
| Table 11 - MLL's Five Largest Customers .....                    | 43  |
| Table 12 - Impact of Key Economic Activities .....               | 49  |
| Table 13 - Blenheim GXP .....                                    | 51  |
| Table 14 - Zone Substation Loadings .....                        | 56  |
| Table 15 - Major Classes of Assets .....                         | 59  |
| Table 16 - Pole Types Used .....                                 | 61  |
| Table 17 - Summary of 2011 DGA Tests .....                       | 68  |
| Table 18 - Fault Levels .....                                    | 68  |
| Table 19 – SCADA Connected Equipment/Communication Type .....    | 79  |
| Table 20 - Justification for Asset Classes .....                 | 83  |
| Table 21 - Key Service Level Targets .....                       | 85  |
| Table 22 - Detailed Service Level Targets .....                  | 86  |
| Table 23 - Targets for maximum number of interruptions .....     | 87  |
| Table 24 - Summary of Efficiency Measures .....                  | 89  |
| Table 25 - Summary of Planning Trigger Points .....              | 92  |
| Table 26 – Development Work Prioritisation Criteria .....        | 95  |
| Table 27 - Overall Growth Rates .....                            | 97  |
| Table 28 - Zone Substation Loadings and Growth .....             | 100 |
| Table 29 - Summary of Approaches to Trigger Points .....         | 102 |
| Table 30 – Network Capital Expenditure Budget .....              | 107 |
| Table 31 - Capital Expenditure Budget 2016 .....                 | 108 |
| Table 32 – Renewal requirements for major asset categories ..... | 121 |
| Table 33 - Key Preventative Maintenance Regimes .....            | 122 |
| Table 34 – Estimated Operational Expenditure 2015 to 2025 .....  | 129 |
| Table 35 - Renewal Expenditure .....                             | 130 |
| Table 36 – Risk Category Types .....                             | 133 |
| Table 37 - Risk Categories .....                                 | 135 |
| Table 38 - Risk Division Across Types .....                      | 136 |
| Table 39 - Risk Treatments implemented by MLL .....              | 140 |
| Table 40 - Highest Risks .....                                   | 142 |
| Table 41 - High Impact Low Probability Risks .....               | 143 |
| Table 42 - Efficiency Measures Results .....                     | 190 |
| Table 43 – Budget and Actual Expenditure 2013/2014 .....         | 191 |

# 1. Background and Objectives of the AMP

Marlborough Lines Ltd's (MLL) Asset Management Plan (AMP) is the key document that translates MLL's data, analysis, procedures, policies and strategic aims into action and defines performance criteria and timeframes. It is also used as a means of communicating MLL's intentions to stakeholders.

MLL is the electricity lines business that conveys electricity throughout Marlborough to 24,500 customer connections (ICPs) on behalf of a number of energy retailers. The diagram below indicates MLL's position in the electricity industry supply chain.

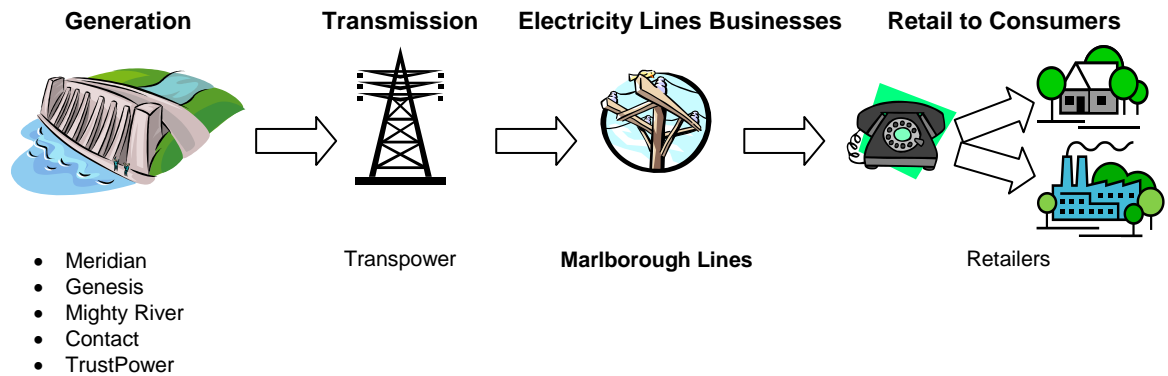

Figure 1 - Electricity Industry Structure

The wider MLL group also includes the following entities:

- A 50% stake in Nelson Electricity, which has its own AMP and is independently disclosed.
- A 13.9% shareholding in Horizon Energy Distribution Ltd, which has its own AMP and is independently disclosed.

The interrelationship of these entities with the various holding companies and shareholders, along with the accounting treatment of results, is described in MLL's annual reports.

The MLL Statement of Corporate Intent also provides information relevant to the AMP. This AMP deals solely with the electricity assets in the Marlborough area and, along with MLL's other plans and policies, combines to demonstrate that MLL is responsibly managing its electricity Network assets consistent with regulatory requirements and best industry practice.

## 1.1 Purpose Statement

The objectives of this AMP, and of the overall Asset Management activity, is to ensure that MLL:

- Maintains and operates all assets in a safe manner to safeguard the health and welfare of staff, customers, contractors, landowners and the general public consistent with legislative requirements and best industry practice.
- Operates and maintains its assets to safeguard the health and welfare of staff, customers and the general public consistent with best industry practice.
- Sets service levels for its electricity Network that will meet customer, community, stakeholder and regulatory requirements.
- Understands the levels of Network capacity, reliability and security of supply required now and in the future, as well as, the issues that drive these requirements.
- Has robust and transparent processes in place for managing all phases of the Network life cycle from initial concept to disposal.
- Adequately considers the classes of risk relative to its Network business, and ensures there are processes in place to mitigate identified risks.
- Makes adequate provision for funding and resourcing all phases of the life cycle of Network assets.
- Makes decisions within structured frameworks at each level within the business.
- Increases its knowledge of its asset components in terms of location, age, condition and the overall Network's likely future behaviour as it ages.

The Asset Management Plan is the key internal planning document used by MLL. Disclosure of the AMP also assists MLL in complying with the requirements of Section 2.6 and Attachment A of the Electricity Distribution Information Disclosure Determination 2012.

This AMP contains a general description of MLL's assets and descriptions of the thinking, policies, strategies, plans and resources that MLL uses, and will use, to manage its assets.

This plan covers the period 1 April 2015 to 31 March 2025 and was approved by the Board of MLL on 31 March 2015.

The next AMP is expected to be prepared and issued in February 2016.

## 1.2 Strategic Planning Documents

Marlborough Lines Limited's key strategic planning documents are its vision and mission statements:

### 1.2.1 Vision

"Our Vision is to be a leader in all that we do in the distribution of electricity and related businesses for the benefit of our customers, shareholder and community".

### 1.2.2 Mission

To exceed our customers' expectations in all aspects of our operations and furnish our shareholder with a commercial return.

MLL's primary objectives are to:

- Operate as a successful business in the distribution of electricity and other related activities.
- Pursue the most efficient use of energy.

In achieving our objectives, we will:

- Develop and maintain customer-responsive transmission, reticulation and distribution systems.
- Ensure that all resources – financial, physical and human – are utilised efficiently and economically.
- Meet our commercial and productivity targets.
- Fulfil market requirements in terms of quality and price on a competitive, commercial basis.
- Ensure the safety of all systems, plant and equipment under our control and promote electrical safety within Marlborough.
- Care for the environment and ensure that any impact of our activities is minimised or, where possible, eliminated.
- Use all legislative powers fairly and in accord with the principles of natural justice.
- Be a good employer by observing and applying best practice in all areas relating to employment.

### 1.3 Statement of Corporate Intent

MLL's SCI is a requirement under Section 39 of the Energy Companies Act 1992, and forms the principal accountability mechanism between MLL's board and the shareholder. The SCI includes *inter alia* revenue and performance targets, which form the heart of the asset management activity. The SCI will be updated in April 2015.

### 1.4 Interaction between Planning Documents

The interaction between MLL's major planning documents and processes is depicted in Figure 2 below. These plans are compiled annually and are subject to regular review during the financial year.

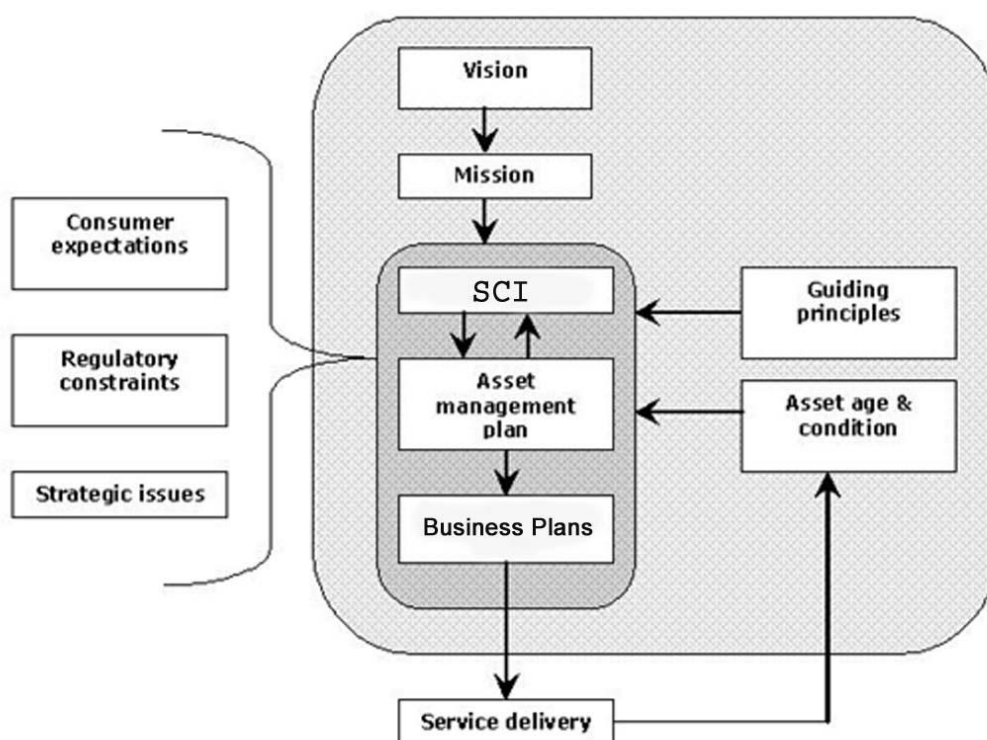

Figure 2 – Interaction between Major Planning Documents

The principal plans resulting from the annual planning process are:

- The Asset Management Plan (AMP), a 10 year plan that documents MLL's thinking, policies, strategies and provides a summary of the expected Asset Management processes and works.
- The annual Business Plan (BP), a one year plan that specifies works in detail.

Table 1 outlines the principal guides to decision making within MLL.

| Category    | Description of Guide                            | Decisions to be Guided   |
|-------------|---|--|
| Policies    | Vision  | All organisation decisions.  |
|             | Mission   | All organisation decisions.  |
|             | Non-asset Solutions                             | Purchasing decisions in terms of whether alternative options can be considered.  |
|             | Distributed Generation                          | Whether distributed generation should be installed and on what terms & conditions.   |
|             | Redeployment & Upgrade of Existing Assets       | Whether and how assets should be either redeployed or upgraded.  |
|             | Purchase of New Assets                          | Whether new assets should be purchased.  |
|             | Adoption of New Technology                      | Whether new technologies should be adopted.  |
|             | Disposal of Assets                              | How assets should be disposed of.  |
| Plans       | Network Standards                               | How Assets are to be constructed   |
|             | Strategic Plan                                  | High level corporate decisions including growth & investment and responses to competitive and regulatory issues.   |
|             | Asset Management Plan                           | Asset maintenance, operational and investment decisions.   |
|             | Risk Management Plan                            | Whether the level of risk implicit in various options falls within MLL approved limits, controls needed to reduce risk.  |
|             | Contingency Plan                                | Responses to defined contingent events.  |
| Standards   | Annual Business Plan                            | Allocation of resources to activities.   |
|             | ISO 9001:2008                                   | Critical business processes.   |
|             | ISO 14001:2004                                  | Minimise effects of activity on environment.   |
|             | OHSAS 18001:2007                                | Maximise safety of staff, contractors and public.  |
|             | AS/NZS 4360                                     | Risk assessment & mitigation.  |
|             | NZS 7901:2014                                   | Public Safety Management System.   |
|             | Technical eg. IEC, BS                           | Technical design & engineering.  |
| Legislation | Financial eg. GAAP, IAS                         | Financial reporting & disclosure.  |
|             | Electricity Act 1992                            |  |
|             | Commerce Act 1986                               | Disclosure of information, restraining anti-competitive behaviour, setting appropriate tariff levels, ensuring supply reliability does not materially decline. |
|             | Companies Act 1993                              | Requirement to file various returns.   |
|             | Health & Safety in Employment Act 1992          | Requirement to provide a safe & healthy workplace.   |
| Regulations | Resource Management Act 1991                    | Requirement to comply with all restrictions on use of natural resources defined in the district and regional plans.  |
|             | Electricity Regulations                         | Most decisions related to Network assets.  |
|             | Electricity Information Disclosure Requirements | What needs to be disclosed and by when.  |

Table 1 - Guides to Decision Making

## **1.5 Planning Period**

A rolling 10 year horizon has been adopted covering the period 1 April 2015 to 31 March 2025. The activities for the first four years of the AMP are more certain, and the activities for the first year form the basis of MLL's 2015/2016 business plan.

The activities described in this AMP are considered appropriate to provide, maintain and operate assets that will meet the projected levels of service. Should there be a change to customer requirements, greater or lesser levels of activity may be required subject to MLL's ability to fund those activities.

## **1.6 Date Approved by Directors**

This plan was approved by the Board of Directors on 31 March 2015.

## **1.7 Description of Stakeholder Interests**

Marlborough Lines Ltd (MLL) defines its stakeholders as any person or class of persons that:

- has a financial interest in MLL (be it equity or debt) and/or;
- pays money to MLL (either directly or through an intermediary) for delivering service levels and/or;
- is physically connected to the Network and/or;
- uses the Network for conveying electricity and/or;
- has an interest in land where MLL assets are located on the land; or has an interest in land that provides access to MLL assets and/or;
- supplies MLL with goods or services and/or;
- is affected by the existence, nature or condition of the Network (especially if it is in an unsafe condition) and/or;
- has a statutory obligation to perform an activity in relation to the Network's existence or operation such as: request disclosure data, regulate prices, investigate accidents, include in a District Plan, archaeological sites, Wahi Tapu sites etc and/or;
- has an interest in the safety of the Network and/or;
- is employed by MLL.

Figure 3 below highlights MLL’s key internal and external stakeholder groups as well as the nature of their relationships with MLL.

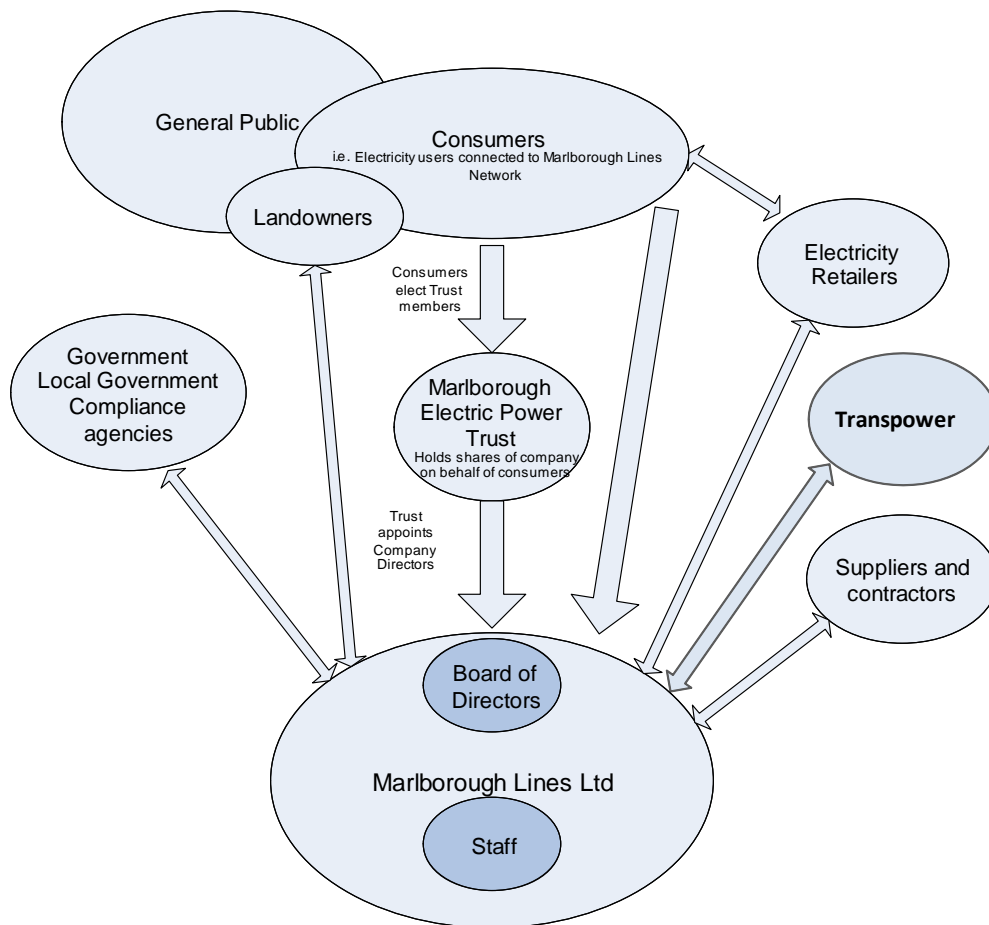

**Figure 3 – Stakeholders**

The suppliers and contractors group includes a wide range of business and service providers including: equipment suppliers, legal and professional advisors, bankers, insurers, Transpower and subcontractors.



Table 2 gives a general indication of the most significant interests of various stakeholders. It is recognised that most stakeholders will generally have an interest in all aspects of the business.

| Stakeholder                               | Interests |       |                |        |            |                   |
|---|-----------|-------|----------------|--------|------------|-------------------|
|   | Viability | Price | Supply Quality | Safety | Compliance | Energy Efficiency |
| Marlborough Electric Power Trust          | ✓         | ✓     | ✓              | ✓      | ✓          | ✓                 |
| Bankers                                   | ✓         | ✓     |                | ✓      | ✓          |                   |
| Connected Customers                       | ✓         | ✓     | ✓              | ✓      | ✓          | ✓                 |
| Energy Retailers                          | ✓         | ✓     | ✓              | ✓      | ✓          | ✓                 |
| Mass-market Representative Groups         | ✓         | ✓     | ✓              | ✓      | ✓          | ✓                 |
| Industry Representative Groups            | ✓         | ✓     | ✓              |        |            |                   |
| Staff and Contractors                     | ✓         | ✓     |                | ✓      | ✓          | ✓                 |
| Suppliers of Goods and Services           | ✓         | ✓     |                |        |            |                   |
| Public (as distinct from customers)       |           |       |                | ✓      | ✓          |                   |
| Landowners                                |           |       |                | ✓      | ✓          |                   |
| Councils (as regulators)                  |           |       |                | ✓      | ✓          | ✓                 |
| NZTA                                      |           |       |                | ✓      | ✓          |                   |
| Ministry of Economic Development          |           | ✓     |                | ✓      | ✓          | ✓                 |
| Energy Safety Service                     |           |       |                | ✓      | ✓          |                   |
| EECA                                      |           |       |                |        | ✓          | ✓                 |
| Commerce Commission                       | ✓         | ✓     | ✓              |        | ✓          |                   |
| Electricity Authority                     |           |       | ✓              |        | ✓          | ✓                 |
| Electricity and Gas Complaints Commission |           |       | ✓              |        | ✓          |                   |
| Ministry of Consumer Affairs              |           | ✓     | ✓              | ✓      | ✓          |                   |

Table 2 – Stakeholder’s Interests

Table 3 indicates how stakeholders' expectations are identified.

| Stakeholder                               | How Expectations are Identified  |
|---|--|
| Marlborough Electric Power Trust          | By their approval or required amendment of the SCI.<br>Regular meetings between the directors and the trustees.  |
| Bankers                                   | Regular meetings between the bankers and MLL staff.<br>By adhering to MLL Treasury procedure.<br>By adhering to banking covenants.   |
| Connected Customers                       | Regular discussions with large industrial customers as part of their ongoing development need assessment.<br>Regular customer surveys.   |
| Energy Retailers                          | Annual consultation with retailers, regular contact and discussion.  |
| Mass-market Representative Groups         | Informal contact with group representatives.   |
| Industry Representative Groups            | Informal contact with group representatives.   |
| Staff and Contractors                     | Regular staff briefings.<br>Regular contractor meetings.   |
| Suppliers of Goods and Services           | Regular supply meetings.<br>Newsletters.   |
| Public (as distinct from customers)       | Informal talk and contact.<br>Feedback from public meetings.   |
| Landowners                                | Individual discussions as required.  |
| Councils (as regulators)                  | Formally, as necessary, to discuss issues such as assets on Council land.  |
| NZTA                                      | Formally, as required.   |
| Ministry of Economic Development          | Regular bulletins on various matters.<br>Release of discussion papers.<br>Analysis of submissions on discussion papers.  |
| Energy Safety Service                     | Promulgated regulations and codes of practice.<br>Audits of MLL's activities.<br>Audit reports from other Lines Companies.   |
| Commerce Commission                       | Regular bulletins on various matters.<br>Release of discussion papers and direct communications.<br>Analysis of submissions on discussion papers.<br>Conferences following submission process.                         |
| Electricity Authority                     | Weekly update.<br>Release of discussion papers.<br>Briefing sessions.<br>Analysis of submissions on discussion papers.<br>Conferences following submission process.<br>Information on Electricity Authority's website. |
| Electricity and Gas Complaints Commission | Reviewing their decisions in regard to other Lines Companies.<br>Assistance with any complaint investigations.   |

**Table 3 - Identification of Expectations**

Table 4 provides a broad indication of how stakeholder interests are accommodated.

| Interest       | Description  | How Interests are Accommodated   | Asset Management Actions   |
|----------------|--|--|--|
| Viability      | <p>Viability is necessary to ensure that shareholders and other providers of finance, such as bankers, have sufficient reason to keep investing in, or providing funding for MLL (and for shareholders to retain ownership).</p>   | <p>MLL will accommodate stakeholders' need for long-term viability by delivering earnings that are sustainable and reflect an appropriate commercial return on employed capital.</p>   | <p>Ensure expenditure is appropriate to maintain or enhance viability of Network, subject to customer requirements.</p>  |
| Price          | <p>Pricing is a means of gathering the revenue required to operate the business and signal underlying costs. Setting prices correctly is important for our customers and MLL. The pricing methodology adopted by MLL sets appropriate total target revenue and then tariff structures for different categories of consumers. As only a portion of network assets are dedicated to individual ICPs, this process involves elements of cost sharing between consumer groups, an approach commonly taken by most electricity network companies.</p> <p>Regulations currently require that increase in cost of supply in rural area should not exceed that of urban areas. This limits the ability of tariff to be cost reflective in some areas. The low fixed charge regulations also require tariffs to be set at a level for some consumers that means that their service is subsidised by other consumers on the Network.</p> | <p>Target revenue is set at a level which ensures the network business is sustainable in the long term and ensures there are sufficient funds to provide reliable assets.</p> <p>MLL takes a medium term view of revenue requirements so as to avoid prices shocks from year to year.</p> <p>The pricing methodology is expected to be cost reflective to and pricing signals reflect the cost of supply where possible. (The low fixed charge regulations mean that this is not able to be achieved for some consumers). MLL has an exception from applying the Low Fixed charge regulations across some areas on its network, ( those classified as "Remote") which reduces the level of cross subsidisation required.</p> | <p>Although not subject to the Price Control mechanism in the DPQ Path MLL revenue is quite consistent from year to year. MLL aims to fund its work through its annual revenues and therefore plans are to have relatively smooth expenditure from one year to the next.</p> |
| Supply Quality | <p>Emphasis on continuity, restoration and reducing</p>  | <p>MLL will accommodate stakeholders' needs for</p>  | <p>MLL has a strong community mandate to maintain/improve</p>  |

| Interest          | Description  | How Interests are Accommodated  | Asset Management Actions  |
|-------------------|--|---|---|
|                   | flicker is essential to minimising interruptions to customers' businesses.   | supply quality by focusing resources on continuity and restoration and ensuring the assets are of a quality and standard to meet customer requirements.   | reliability and to reduce flicker   |
| Safety            | Staff and contractors must be able to work on our Network in total safety. The general public must be able to move safely around Network Assets. | <p>MLL will ensure that the public is kept safe by ensuring that all assets are structurally sound, live conductors are well out of reach, all enclosures are kept locked, all exposed metal is securely earthed and assets are built and maintained in accordance with legislative requirements and best practice.</p> <p>MLL will ensure the safety of staff and contractors by providing all necessary equipment, improving safe working practices, and ensuring that workers are stood down in unsafe conditions.</p> | All work is subject to rigorous safety standards with safety given the highest priority for expenditure. The Public Safety Management System (PSMS) will document MLL's procedures for ensuring safety of the public. |
| Compliance        | MLL must comply with many statutory requirements ranging from safety to disclosing information.  | <p>MLL will ensure that all safety issues are adequately documented and available for inspection by authorised agencies.</p> <p>MLL will disclose performance information in a timely and compliant fashion.</p>  | Undertake sufficient monitoring and inspection to ensure compliance is maintained.  |
| Energy Efficiency | As a good corporate citizen, MLL will encourage energy efficiency within its own business and for customers.                                     | <p>MLL will consider losses within its system and ensure that these are minimised where practical.</p> <p>MLL will assist customers by providing advice and assistance on energy efficiency.</p>  |   |

**Table 4 - Accommodation of Stakeholder Interests**

### 1.7.1 Managing Conflicting Interests

Most activities result in a need to balance a number of different issues, e.g. quality, cost, time. Finding a balance acceptable to all stakeholders requires that various solutions are carefully considered and priorities evaluated according to the specific circumstances and environment. The general priorities, in order of highest to lowest, for managing conflicting stakeholder expectations and interests are given below:

1. **Safety:** MLL will give top priority to safety. Even if budgets are exceeded or non-compliance arises, MLL will not compromise the safety of its staff, contractors or the public. Safety is fundamental to the way MLL will undertake any activity.
2. **Compliance:** MLL will give priority to compliance, noting that compliance which is safety related will be given highest priority.
3. **Viability:** MLL will give high priority to viability, because without it MLL will cease to exist.
4. **Return:** MLL recognises the need to operate as a successful business and provide a commercial rate of return. This ensures that funding will be available for future activities and ongoing supply continues to be available to customers.
5. **Supply Quality:** This is important to customers to allow them to operate their homes and businesses in a reliable and safe manner. An unreliable supply may drive customers to consider alternatives to grid supply.
6. **Environment:** As a socially responsible organisation, MLL will diligently respect the environment and ensure that its operations are based on sustainable practices. MLL will consider environmental issues in all aspects of its operations and whenever practicable seek to eliminate or mitigate the impact of our operations on the environment.
7. **Energy Efficiency:** Consideration will be given to maximising Energy Efficiency.
8. All other considerations will be given lower priority than those listed above.

Aside from safety, the priority given to these issues may vary slightly from those above, according to the issue(s), their respective magnitudes and the affected stakeholders. In practical terms, these issues are not mutually exclusive and all will factor in the decision process.

### 1.8 Accountabilities & Responsibilities for Asset Management

MLL's accountabilities and accountability mechanisms are shown in Figure 4 and are discussed in detail in the following sections.

The ultimate accountability is to connected customers. The Commerce Amendment Act recognises this accountability and accordingly the price path threshold does not apply to beneficially owned Lines Companies such as MLL. Marlborough Lines Limited undertakes independent surveys of customers annually and the overall satisfaction levels have been greater than 90% for a number of years.

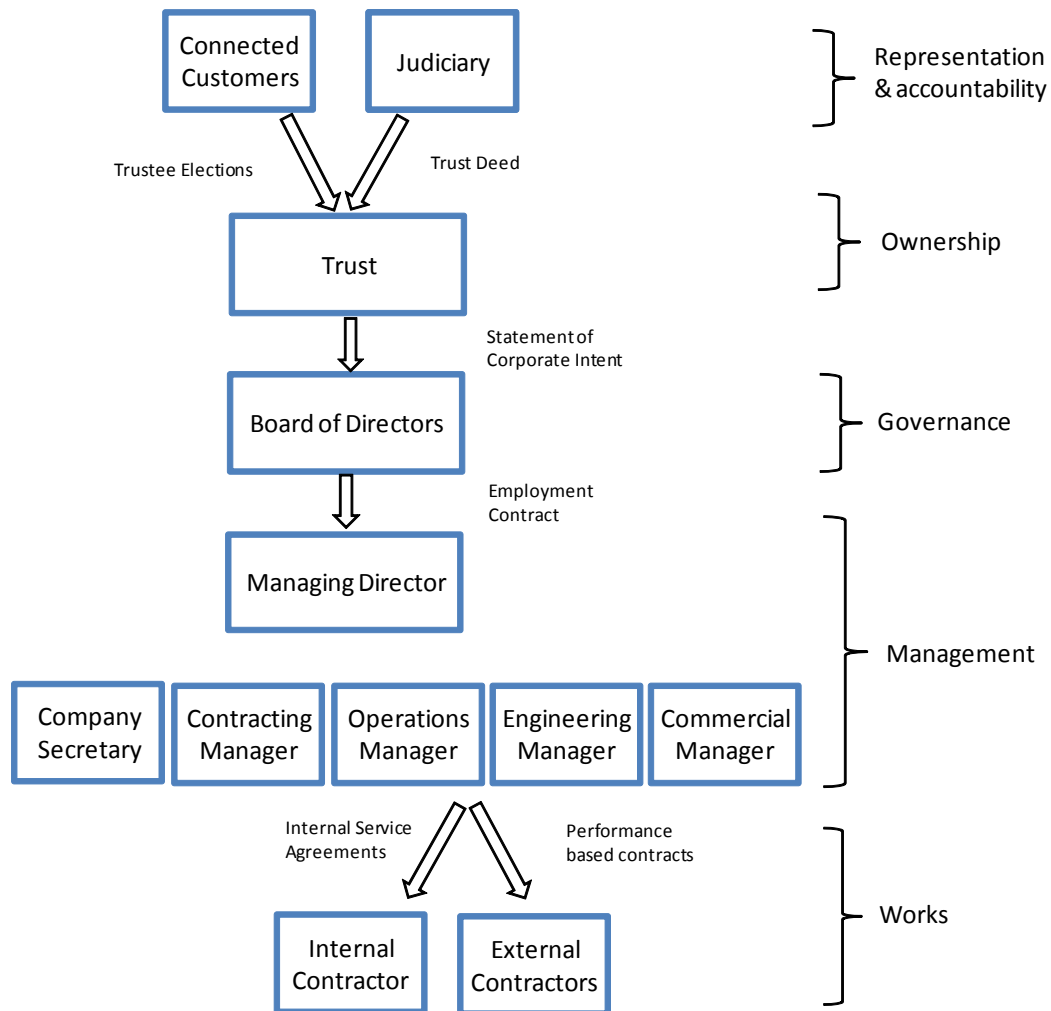

Figure 4 - Accountabilities for Asset Management

### 1.8.1 Accountability at Ownership Level

MLL has a single Shareholder – the Marlborough Electric Power Trust. The Trust currently has six trustees, each of whom holds 4,666,650 shares in MLL on behalf of the Trust. The Trust members are currently:

- Ross Inder (Chair)
- Ian Martella
- Paul Ham
- Malcolm Aitken
- John Cuddon

- Clive Ballett

The Trust is subject to the following three accountability mechanisms:

- an election process.
- the Trust Deed which holds all Trustees collectively accountable to the New Zealand judiciary for compliance with the Trust Deed.
- the provisions of the Trustee Act 1956.

### **1.8.2 Accountability at Governance Level**

Marlborough currently has six directors who are collectively accountable to the Trust through the SCI. The current directors are:

- David Dew (Chair)
- Anthony Beverley
- Ken Forrest (Managing Director)
- James Hay
- Jonathan Ross
- Tim Smit

The Board approves the annual budgets, SCI and this AMP. Each month it receives reports on the overall performance of MLL and key activities undertaken.

### **1.8.3 Board Reporting**

MLL's regular board reports include the following:

- the capital expenditure program (progress and spend against budget).
- the maintenance program (progress and spend against budget).
- incidents and major outages.
- any major changes to asset management processes or practices.

On a quarterly basis the Board receives a report on Legislative Compliance and Risk Management, which includes:

- all health and safety accidents and near-misses.
- all incidents of third party contact with the Network.
- details of major customer works.

#### **1.8.4 Accountability at Managing Director Level**

The Managing Director, Ken Forrest, is accountable for all aspects of MLL's operations to the directors primarily through his employment contract and required objectives of the Board.

#### **1.8.5 Accountability at Management Level**

The second tier of management reports to the Managing Director. Accountability for asset management at the second tier is:

- Accountability for managing the existing assets and planning new assets lies with the Engineering Manager, Wayne Stronach. This role addresses long-term planning issues such as capacity, security and asset configuration.
- Responsibility for minute by minute continuity and restoration of supply lies with the Operations Manager, Brian Tapp, principally through control and dispatch, switching and fault restoration. The Operations Manager also has responsibility for asset maintenance.
- Accountability for the key area of line pricing lies with the commercial manager, Katherine Hume-Pike.
- Accountability for all administrative and financial activities lies with MLL's chief financial officer, Kelvin Deaker.

The key accountabilities of the four second tier managers are to the Managing Director through their respective employment contracts and required performance criteria.

#### **1.8.6 Accountability at Works Implementation Level**

MLL has an in-house contracting department. This operates as a separate division of the company/business. With the implementation of the Electricity Industry Reform Act 1998, many Lines Companies sold their contracting operations. MLL recognised it was very unlikely that active competition would be present in the Marlborough market and therefore chose to retain its contracting staff, rather than being subject to limited competition and consequent price gouging.

MLL Contracting undertakes the majority of the work on the MLL Network. Broadly this is:

- construction of new assets.
- maintenance of existing assets.
- operation of existing assets.

It also undertakes work such as the construction of line extensions for external customers and the operation of hydro electric schemes for Trustpower.



MLL retains relativity with prevailing market rates and undertakes testing from time to time to compare the commercial performance of MLL's Contracting division with other similar businesses in the area and throughout New Zealand.

The Contracting Manager, Stephen McLauchlan, is accountable both to the Operations Manager and Engineering Manager for the quality of work done, and to the Managing Director for the overall performance of the Contracting business unit.



**Photo 1 - Staff undertaking maintenance on 33kV line**

## 1.9 Significant Assumptions

Significant assumptions underpinning this AMP include:

| Assumption   | Sources of Uncertainty of Each Assumption   | Likely Impact of Uncertainty on AMP  |
|--|---|--|
| That customers will continue to want and be willing to pay for a reliable power supply based on the MLL Network.   | Changes in the economy or other factors may lead customers to prefer lower levels of service and reliability  | Constraints on expenditure will lead to reductions in service and reliability.   |
| That the amount of capital expenditure is consistent with the objectives of maintaining a safe and reliable Network which meets the needs of customers and stakeholders. | Uncertainty here is based on the assumptions that there will be no unforeseen events which require an increase in expenditure.                        | May need to revise amount of expenditure if this is not consistent with providing safe and reliable Network.   |
| That the current regulatory framework will continue, albeit with some changes and refinements.   | A change in government may lead to changes in the regulatory framework.   | Plan will need to be revised to comply with regulatory framework.  |
| That MLL will be able to earn an appropriate commercial return on all capital expended.  | MLL is not currently achieving a commercial return, costs need to decrease or prices to increase.   | If unable to achieve an appropriate return on new investment, then renewal, upgrading and/or maintenance activities may need to be reduced.  |
| That load will increase as indicated by other sections of this plan.   | Load increases are based on best estimates, however they are inherently inaccurate and vary according to international, national and local economies. | Changes to activities, in particular, growth - related activities. Expenditure reviewed as it occurs, AMP reviewed at least annually.  |
| That no major disasters or widespread systemic problems will occur.  | While contingency planning and emergency response plans are in place, it is not possible to predict the extent or timing of disasters.                | Significant change possible following major event such as damage from earthquake, tsunami.   |
| That there will not be widespread introduction of distributed generation (DG).   | Lowering of price point on solar (PV) and other generation, increases in cost of generation from wholesale market.                                    | May lead to further investment in locations not identified within report. In general such investment will be funded by generators. May lead to increases in prices for loads as regulations mean that DG does not fund operations and maintenance (or future renewal). |
| That no major new loads or major generation will be installed during the period of this plan.  | Lack of knowledge, all known loads taken into account.  | Changes in AMP activities and investment   |
| That the Marlborough District Council (MDC) will contribute to the cost of overhead to underground conversion programmes.  | MDC expenditure is constrained by a range of factors outside the scope of this AMP.   | May lead to deferral of plans to convert overhead to underground.  |
| Price Inflation Assumptions  | Taken as 1.5% based on financial sector outlooks (Treasury and ANZ Bank).   | May give incorrect nominal dollar amounts. Prices can be worked back into today's dollars.   |

**Table 5 – Significant Assumptions**

The assets which are covered by this Asset Management Plan generally have a very long life, i.e. 45 to 70 years and accordingly by reviewing this plan regularly it is possible to take account of variations or errors in the assumptions listed above.

## 1.10 Factors That May Lead to Material Differences

The following factors may lead to material differences between this disclosure and future outcomes:

| Factor  | Likely Outcome   | Impact on AMP Performance   |
|---|--|---|
| Economic environment, especially in the wine, forestry and aquaculture sectors. | Increased kWh throughput, leading to additional revenue.<br>Increased kW demand, leading to new capacity projects. | Some changes in growth related expenditure within first 3-5 years may need more significant changes thereafter.       |
| Unit cost of key inputs such as copper, steel, glass, plastic, diesel, labour.  | Increased cost of all classes of work.   | Reduced volume of work (leading to declining service and/or reliability)<br>Higher prices to recover increased costs. |
| Unexpected systemic failure of assets.  | Changes to components.<br>Alterations in expenditure.  | Some plans may not be achieved as resources are redeployed, expenditure may need to increase.                         |

Table 6 – Disclosures/Future Outcomes

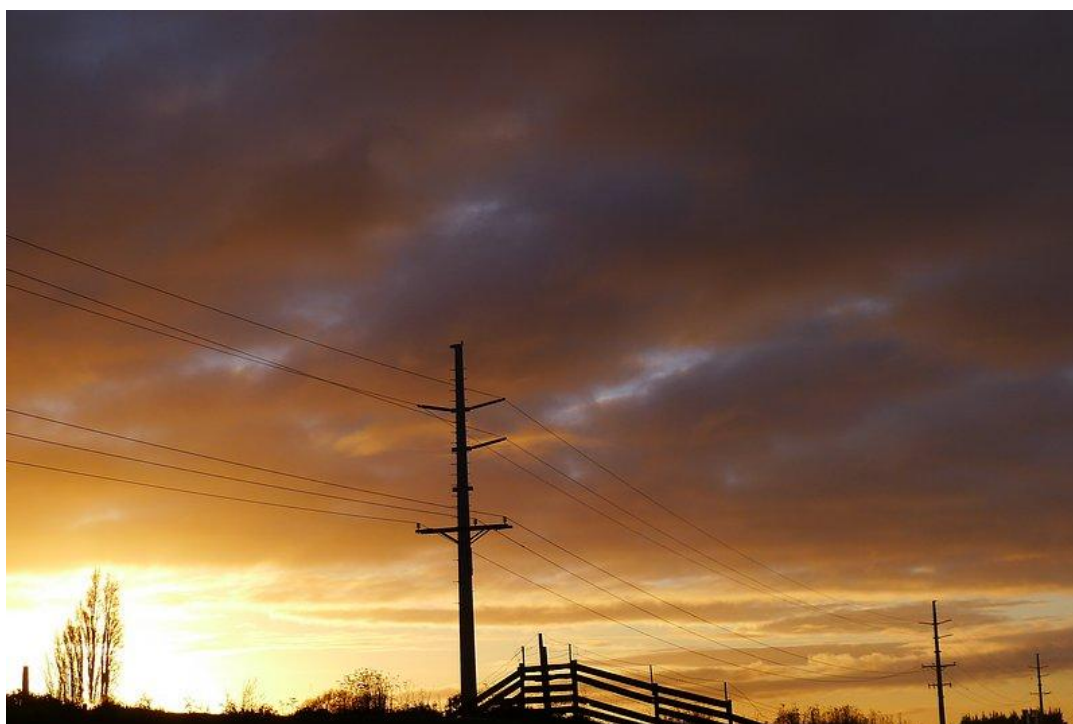

Photo 2 - renewed 33kV Line Lansdowne Park to Riverlands - Steel poles

## 1.11 Overarching Asset Strategy

### 1.11.1 Asset Management Policy

MLL will:

- define its supply quality targets principally by consulting its respective customer classes, but also by considering other strategic, economic and regulatory drivers;
- achieve supply quality targets by maintaining existing asset and building new assets in accordance with MLL's design and construction standards, prevailing engineering standards and best applicable industry practice;
- maintain and build its Network and assets to minimise lifecycle costs, recognising that its' owners are also its customers;
- seek to continuously improve its asset management practices to a level that is appropriate for a medium-sized, customer-owned EDB. Priority will be given to strengthening practices which result in greatest benefit for stakeholders.



Photo 3 - Switchgear at Cloudy Bay substation

### 1.11.2 Service levels

MLL will:

- provide a safe environment for the public and staff by ensuring that its Network is safe;
- continue towards the objective of halving fault SAIDI minutes from the average of the five year period ended 31 March 2010 (i.e. 165 minutes). For this year MLL will target an overall fault SAIDI of 115 minutes and work on reducing this to 90 minutes;
- target to have less than 70 minutes of planned SAIDI.
- meet the minimum of statutory levels or agreed terms for supply voltage;
- follow its security of supply standards unless the required investment levels are inconsistent with good engineering practice and/or commercial criteria;
- endeavour to limit flicker to levels specified by AS/NZS 61000.3.7:1996, by educating and encouraging customers to comply with the standard;
- endeavour to limit harmonics to levels specified in ECP 36:1993, by educating and encouraging customers to comply with the standard;
- target a power factor of greater than 0.95 lagging at times of high load on the Network;
- facilitate connection of embedded generation where it doesn't compromise safety, Network operation, quality of supply to other customers, or power factor. MLL may require an embedded generator to pay the economic costs of connection where these costs are consistent with Part 6 of the Electricity Industry Participation Code;
- interrupt supply to domestic customers in preference to hospitals, industrial and commercial customers for purposes of emergency demand management.

### 1.11.3 Asset configuration

MLL will:

- work with Transpower to minimise the fixed asset requirements commensurate with providing a reliable and secure supply to customers;
- take a long-term view of asset requirements, noting that customers ultimately benefit from well-planned investments;
- build all future sub-transmission lines at 66kV or 110kV;
- ensure that where possible, land purchases for new zone substations provide sufficient land to allow additional future transformer capacity to be installed;
- build all future rural distribution lines at 22kV;

- use fixed generators on long radical feeders such as the those supplying the Marlborough Sounds to improve reliability of supply;
- use portable generators to improve reliability and reduce the effects of faults and planned work on customers.

#### **1.11.4 Resourcing**

MLL will:

- identify the required skill sets on a timeframe equal to the Asset Management Plan, and ensure that recruitment and training plans are consistent with needs and where appropriate use relevant contractors ;
- retain its current field services business for fault restoration, inspections, maintenance and renewal work;
- use contractors/consultants where its staff do not have the required skill sets, where resources are inadequate for works programmes or where it is more cost effective to do so, e.g. specialist work such as civil design, radio equipment installation and maintenance.

#### **1.11.5 Materials:**

MLL will:

- only use materials and equipment approved by its own internal standards and policies;
- reject offers that do not comply with its internal standards and policies, with relevant national standards, and/or with industry practice;
- consider the total lifecycle costs of materials when assessing offers;
- recycle materials where practical, taking into account the total lifecycle costs and overall risk;
- purchase timber products such as cross-arms and poles from sustainable and renewable resources.

### 1.11.6 Risk:

MLL will:

- regularly review its risk position using a prevailing standard such as ISO 31000;
- adopt a risk-averse position, especially with regard to worker and public safety;
- err on the side of over-investment in Network capacity, recognising that under-investment can lead to supply interruption and the overall economic cost suffered by customers can be markedly greater than the cost of prudent investment taken before it is required. Within the network industry invariably to wait until the demand exists is too late.



Photo 4 - Ward Substation

## 1.12 Overview of Systems and Information

The interaction between MLL's major planning documents and processes is depicted in Figure 5 below. These plans are compiled annually and are subject to regular review during the financial year.

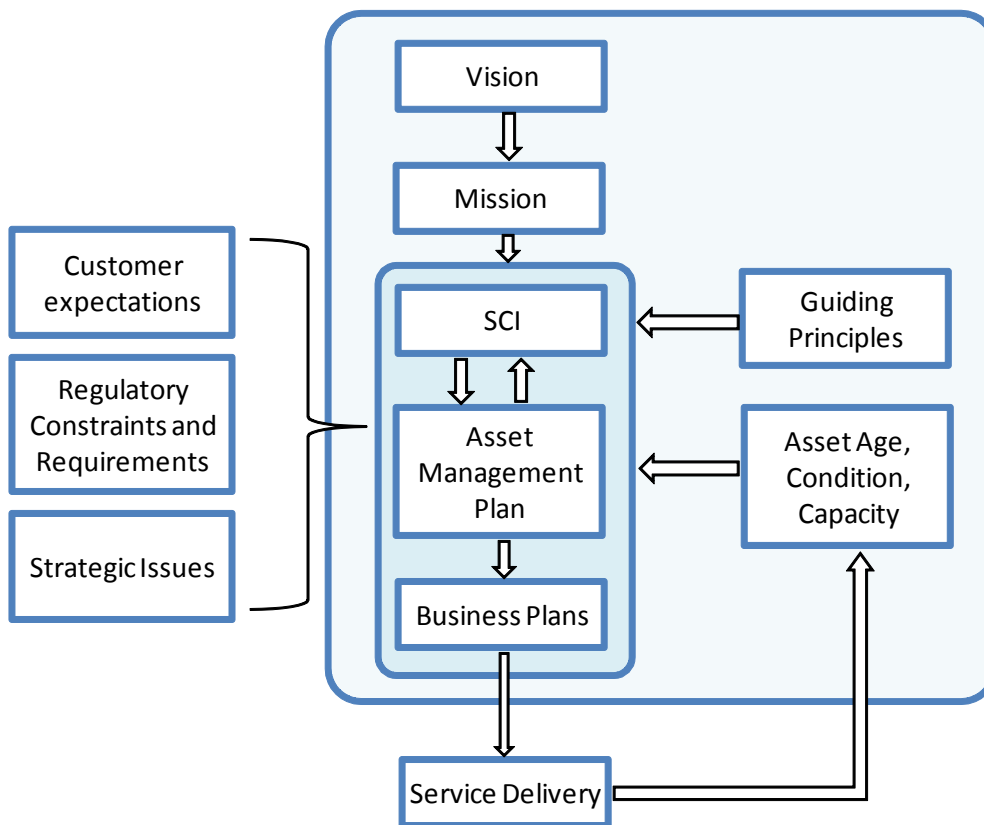

Figure 5 – Interaction Between Major Planning Documents

The vision statement guides Marlborough Lines Ltd's mission statement. These documents provide an overall direction to the company's key planning documents, the Statement of Corporate Intent (SCI) and the AMP (this document). Business plans and annual budgets are developed from the Asset Management Plan.

The SCI is the key accountability mechanism between MLL's board and the Shareholder (the Marlborough Electric Power Trust). The SCI includes *inter alia* revenue and performance targets, which form the heart of the asset management activity. The SCI is updated annually.



Table 7 outlines the principal guides to decision making within MLL.

| Category           | Description of Guide                        | Decisions to be Guided   |
|--------------------|---|--|
| <b>Policies</b>    | Vision                                      | All decisions.   |
|                    | Mission                                     | All decisions.   |
|                    | Non-asset Solutions                         | Purchasing decisions in terms of whether alternative options can be considered.  |
|                    | Distributed Generation                      | Whether distributed generation should be installed and on what terms and conditions.   |
|                    | Redeployment and Upgrade of Existing Assets | Whether, and how, assets should be redeployed or upgraded.   |
|                    | Purchase of New Assets                      | Whether new assets should be purchased.  |
|                    | Adoption of New Technology                  | Whether new technologies should be adopted.  |
|                    | Disposal of Assets                          | How assets should be disposed of.  |
|                    | Network Standards                           | How Network assets are to be constructed.  |
| <b>Plans</b>       | Strategic Plan                              | High level corporate decisions including growth and investment, and responses to competitive and regulatory issues.  |
|                    | Asset Management Plan                       | Asset maintenance, operational and investment decisions.   |
|                    | Risk Management Plan                        | Whether the level of risk implicit in various options falls within MLL approved limits, or controls are needed to reduce risk.                                     |
|                    | Contingency Plan                            | Responses to defined contingent events.  |
|                    | Annual Business Plan                        | Allocation of resources to activities.   |
| <b>Standards</b>   | ISO 9001:2008                               | Critical business processes.   |
|                    | ISO 14001:2004                              | Minimise effects of activity on environment.   |
|                    | OHSAS 18001:2007                            | Maximise safety of staff, contractors and public.  |
|                    | AS/NZS 4360                                 | Risk assessment and mitigation.  |
|                    | NZS 7901:2014                               | Public Safety Management System (certification achieved 2012).   |
|                    | Technical e.g. IEC, BS                      | Technical design and engineering.  |
|                    | Financial e.g. GAAP, FRS                    | Financial reporting and disclosure.  |
| <b>Legislation</b> | Electricity Act 1992                        |  |
|                    | Commerce Act 1986                           | Disclosure of information, restraining anti-competitive behaviour, setting appropriate tariff levels, and ensuring supply reliability does not materially decline. |
|                    | Companies Act 1993                          | Requirement to file various returns.   |
|                    | Health & Safety in Employment Act 1992      | Requirement to provide a safe and healthy workplace.   |
|                    | Resource Management Act                     | Requirement to comply with all restrictions on   |

| Category           | Description of Guide                            | Decisions to be Guided   |
|--------------------|---|--|
|                    | 1991  | use of natural resources defined in the district and regional plans. |
| <b>Regulations</b> | Electricity Regulations                         | Most decisions related to Network assets.                            |
|                    | Electricity Information Disclosure Requirements | What needs to be disclosed and when.                                 |

**Table 7 - Guides to Decision making**

MLL recognises the importance of adopting best practice in its management. It also recognises it is important to provide confidence that its various management practices are consistent with required standards.

MLL has ISO accreditation for:

- Management Systems – ISO 9001:2008;
- Environmental Management – ISO 14001:2004; and
- Occupational Health and Safety – OHSAS 18001:2007.
- Public Safety – NZS 7901:2014.

The ISO 9001 quality management system ensures that MLL’s procedures and work practices meet with recognised industry best practice. Compliance with the system’s procedures is integral to MLL’s operations and, as such, regular audits (both internal and external) are completed.

As part of its accredited ISO 14001:2004 environmental management system one of MLL’s key objectives is that:

*"MLL will take a leadership role in environmental compliance activities and will demonstrate our commitment to caring for the environment."*

This will be achieved through the avoidance or mitigation of any adverse effects of MLL’s activities upon the natural and built environment as well as the local community. All areas of MLL’s operation have documented environmental policies and all staff are required to undertake their work in accordance with these policies.

Where appropriate, consultation will be undertaken to assist in obtaining the best possible outcome for all affected parties.

Because MLL regards safety as an integral part of its business it was one of the first New Zealand companies to achieve OHSAS 18001:2007 accreditation. This is in addition to the company’s ACC Tertiary status, which enables MLL to gain a 20% reduction in ACC premiums.



Photo 5 - testing new recloser, Saddle Hill

### 1.13 Limitations of Asset Management Data

The limitations in Asset Management data and information are:

| Nature of Data                     | Limitation   | Implications of Limitation  | Likely Impact on AMP   |
|------------------------------------|--|---|--|
| Pole condition data                | <ul style="list-style-type: none"> <li>Inability to accurately determine pole condition</li> </ul>   | <ul style="list-style-type: none"> <li>Possibility of premature replacement of sound poles.</li> <li>Possibility of unsound poles remaining in service.</li> </ul>                                    | <ul style="list-style-type: none"> <li>Increased use of high cost monitoring, e.g. radioactive sources</li> <li>Increases in failure, need to renew sections/pole types</li> <li>Increased faults/outages</li> </ul> |
| Underground Cable Condition        | <ul style="list-style-type: none"> <li>Inability to know precise condition or expected life – mainly applies to older XLPE cables</li> </ul>   | <ul style="list-style-type: none"> <li>Unexpected cable faults/failures – cables generally very reliable</li> <li>Cable difficult to replace</li> <li>Extended outages while fault finding</li> </ul> | <ul style="list-style-type: none"> <li>Planning to replace older cables or provide alternative supplies</li> <li>Planning to replace Cable T-joints with RMUs to allow better isolation/fault finding</li> </ul>     |
| Overhead Conductor Condition       | <ul style="list-style-type: none"> <li>Very difficult to assess this accurately and in cost effective manner</li> </ul>  | <ul style="list-style-type: none"> <li>Conductor failure may occur, all such failure recorded and monitored</li> </ul>  | <ul style="list-style-type: none"> <li>Renewal activities may need to be re-prioritised</li> </ul>   |
| Distribution Transformer Condition | <ul style="list-style-type: none"> <li>Small Distribution transformers generally run to failure, no condition assessment aside from 5 yearly visits and external inspections.</li> </ul> | <ul style="list-style-type: none"> <li>Failure rate may increase beyond that expected, although this is monitored and age profile accurately known.</li> </ul>  | <ul style="list-style-type: none"> <li>Need to monitor failure rates and may need to alter expenditure</li> </ul>  |

Table 8 – Limitations in AMP data

## 1.14 Description of Key Processes

### 1.14.1 Processes for inspections and maintenance

Regular inspections are scheduled using the WASP (see section 1.14.5) maintenance module. This allows tasks to be scheduled and grouped into efficient groups and ensures work is completed in a timely manner.

Maintenance tasks, such as replacement of a cross-arm generally result from surveillance by staff and contractors. All work is approved by the Network division, the Contracting division collects the work into efficient groups and undertakes the work according to its location and criticality. Estimates of cost are approved early in the process and the actual costs, tasks completed and tasks outstanding are reviewed on a monthly basis.

All tasks are shown on the Geographical Information System (GIS) and prior to being approved for maintenance, consideration is given to the need for asset renewal, e.g. if most of the poles in a section of line need attention, it may be an indicator that the line is at the end of its life and should be replaced, rather than each pole being replaced individually.

### 1.14.2 Processes for development projects

Network development and renewal work are undertaken as projects. At the beginning of the year an overall programme for work is developed and agreed between the Network and Contracting divisions. Project managers are assigned to each project to:

- consider the brief and reasons for the project
- develop a project plan covering the design and implementation
- produce a design.
- obtain a quotation for the work from MLL's contracting division (or outside contractor)
- obtain all required permissions, such as easements, consents
- approve the quotation
- order any long lead items/large capital items
- liaise with the Contractor's work manager as to actual implementation
- arrange commissioning
- finalise payments and as-built documentation
- complete project review/close-out

As major issues arise they are dealt with by the project manager, or escalated as required. The WASP system and SQL databases provide information on costing

and progress. The complete work programme is reviewed on a monthly basis to consider progress, priorities and any outstanding issues.

### **1.14.3 Processes for performance measurement**

The principal asset management system at MLL is WASP, an asset and works order management system.

Asset Information, such as line lengths and distribution transformer capacity is contained within WASP. Information on connected ICPs is contained in Velocity software and replicated within WASP. The asset relationship is stored within WASP.

Reliability and regulatory reporting uses the asset relationships to determine any ICPs affected by an outage. This module has been configured to suit the information disclosure requirements of the Ministry of Economic Development and the Commerce Commission.

For each fault, the time and operation of assets is recorded and the Network reliability figures (i.e. SAIDI, SAIFI, etc) are calculated based on the connectivity model and customer connection data.

### **1.14.4 Wider processes, information resources and software**

Marlborough Lines Ltd makes use of a wide range of systems, processes and technology assets to capture, utilise, store and present information derived from, and about, its assets. This information is continually updated as the status of the Network changes (e.g. load variations, switching, faults, connection of new customers, new investments). Processed information can range from single items of raw data used by operations staff in making real-time decisions to highly processed and aggregated data used by executives in making long-term decisions.

MLL's IT and information systems are being renewed in 2015 to ensure that the new disclosure information requirements required by the Commerce Commission as well as management information is captured and produced in a cost effective manner.

This is a full replacement of WASP and BASIX (asset management and works order systems) with "infor EAM" and a new implementation of an outage management and call and dispatch system, Milsoft, within Marlborough Lines. The GIS upgrade part of this project has already been completed.

The purpose of this project is to provide the assets and works order element of the business; (i) efficiency through standardisation of key business processes, (ii) effectiveness via information being centralised, and (iii) cost controlled by means of higher visibility of financials throughout the business, thus seeking to continually improve the core competency of managing electrical networks in accordance with the overarching organisational vision.

### 1.14.5 Asset and Works Management Software

The current asset management system at MLL is WASP, an asset and works management program, which has been in use since 2004. WASP consists of a series of modules built around a central asset register of the approximately 100,000 items that make up MLL's Network assets. The functionality covered by these modules includes:

- asset creation, modification and deletion
- asset attribution and attribution history
- project and works management (including work design and estimation)
- inventory integration
- outage and fault management and data recording
- maintenance management
- reliability and regulatory reporting
- GIS (map viewer) integration

Most asset information is contained in the EMS-WASP with the GIS (ESRI) containing the spatial (location) data. These two databases are synchronised, i.e. they contain data in common and new data is entered into each system simultaneously through a database interface.

The Network is inspected every five years and the condition and asset information updated accordingly. MLL is now on the third cycle of asset inspections and accordingly has a high degree of confidence in the accuracy of the asset information and condition assessment.

Video surveillance of the HV network is ongoing where appropriate. This video capture supplements the other data on vegetation. Tablets and other mobile devices are being utilised for data capture in the field, thereby reducing transcription errors and improving efficiency.

### 1.14.6 Key Information Locations

| Repository  | Information   | Key users   | Notes  |
|---|---|---|--|
| Asset Information(EMS-WASP/BASix)<br><br>Being upgraded 2015 to Infor EAM | <ul style="list-style-type: none"> <li>• Zone substation assets</li> <li>• Location</li> <li>• Technical specifications</li> <li>• History</li> <li>• Test records</li> <li>• Network outages</li> <li>• Financial data</li> <li>• Asset Condition</li> </ul> | Most staff  | Main asset data repository uses SQL, also used for maintenance and capital works programs.   |
| GIS (ESRI)  | <ul style="list-style-type: none"> <li>• Line asset type</li> <li>• Line connectivity</li> </ul>  | Most staff  | A map-based view of WASP data, as well as views of maps, and data relating to the environment such as roads, archaeological sites. |
| Design records and project files  | Calculations, analysis of options, protection reviews.  | Engineering staff   |  |
| Easement records  | <ul style="list-style-type: none"> <li>• Landowner details</li> <li>• Agreements</li> </ul>   | Engineering, operations and contracting staff                 | Also shown on GIS.   |
| Various maps  | <ul style="list-style-type: none"> <li>• Asset location</li> </ul>  | All staff as required   | Mainly superseded by GIS.  |
| SCADA   | Network status e.g. loads, switch positions, tapchanger positions <ul style="list-style-type: none"> <li>• Faults and outages</li> <li>• Inspection data</li> </ul>   | Engineering, operations and development staff                 | Current status as well as historical logs and graphs of loading etc.   |
| Milsoft   | <ul style="list-style-type: none"> <li>• Outage management system</li> <li>• Engineering Analysis</li> </ul>  | Operations and administration staff                           | Network status   |
| Fault record sheets   | <ul style="list-style-type: none"> <li>• Description and duration</li> <li>• Likely cause</li> </ul>  | Operations manager, Network management and staff              | Reviewed regularly to look for systemic issues and ways to improve service.  |
| Switching instructions and drawings                                       | <ul style="list-style-type: none"> <li>• Operating instructions</li> </ul>  | Network, operations and contracting staff                     | Used for daily operation of Network.   |
| Finance 1   | <ul style="list-style-type: none"> <li>• Financial data</li> <li>• Inventory</li> <li>• Payroll</li> </ul>  | Administration, Stores  | Keeps accounting records. NB WASP also maintains project- based costings for works.  |
| Velocity  | <ul style="list-style-type: none"> <li>• Connection data</li> <li>• Billing data</li> <li>• ICP management</li> </ul> Load control relays not owned by MLL  | Operations and administration staff<br><br>Commercial Manager | ICP based data, WASP also displays this data.  |
| ISO System Quality  | <ul style="list-style-type: none"> <li>• Policies and procedures</li> </ul>   | All staff   | Procedures, policies and guidelines related to design, operation, health and   |

| Repository                                      | Information   | Key users  | Notes   |
|---|---|--|---|
| Health & Safety<br>Environment<br>Public Safety |   |  | safety, public safety and environmental practice. |
| Network Standards                               | <ul style="list-style-type: none"> <li>Design and policy information for design and construction of Network assets</li> </ul> | Contractors, MLL design staff, operators                               |   |
| Emergency Response Plan                         | <ul style="list-style-type: none"> <li>Information for use in civil emergencies, e.g. earthquake, major storms</li> </ul>     | Engineering, contracting and administration staff during severe events |   |

**Table 9 - Information Repositories**

### 1.14.7 Databases

All of MLL's core systems utilise Microsoft SQL databases, which simplifies reporting across multiple systems. MLL utilises Microsoft Reporting Services to track the performance of a range of asset related activities such as:

- project and work / job number analysis
- circuit breaker technical settings (i.e. protection)
- inspection and testing results
- defect reporting
- logging database changes to signal changes required in Network models (i.e. load flow)
- Network configuration changes

All of these reports are available directly from MLL's intranet. Some are scheduled in the database and are emailed directly to subscribers where the pre-set conditions are met.



### 1.15 Overview of Documentation, controls and review process

Key aspects of the AMP communication and participation include:

| Stakeholder              | Communication method  | Nature of participation   |
|--------------------------|---|---|
| MLL engineering staff    | Assigned tasks to complete  | Review, preparation of technical studies, asset failure reviews, fault and reliability studies. |
| MLL board                | included in board papers  | Signatories   |
| MLL internal contracting | Receives copy from engineering manager                              | Determines forward work load and resourcing requirements  |
| Statutory bodies         | Receives disclosure copy  | Assess for compliance   |
| Community at large       | Download from website, relevant information included in newsletters | Varies – anything from understanding forecast reliability to noting location of planned lines   |

Table 10 - AMP Communication

Key parts of the asset management systems are documented within the ISO quality assurance systems. All of these procedures are subject to regular review and key outcomes are reported to a monthly meeting of senior management.



Photo 6 - 11kV line through Trees

## 2. Assets Covered

### 2.1 Details of Assets

#### 2.1.1 Background

Marlborough Lines Limited's Network originally began as three historically distinct networks:

- The Marlborough Electric Power Board (M.E.P.B.), which was established in 1927 and began to supply the region from its own 1MW Waihopai River scheme.
- The Havelock Town Board electricity department, which commenced in 1917 with a 9kW Pelton Wheel, and was merged into M.E.P.B. in 1926.
- The Picton Borough Council electricity department, which commenced in 1917 with a 10kW Pelton Wheel, and was merged into M.E.P.B. in 1947.

These Networks are now electrically connected and operate as a single integrated system.

MLL is based in Blenheim and takes supply from the Transpower Grid via three 110kV circuits to a single point of supply (Grid Exit Point – GXP) in the Blenheim suburb of Springlands. Supply to the province then radiates out to a number of isolated rural areas including the Marlborough Sounds, Molesworth Station and the southern Marlborough coast; an area bordered by the Pacific Ocean on one side and the inland Kaikoura mountains on the other.

As there is only a single GXP, MLL operates an extensive 33kV Network in order to provide a reliable supply throughout the region.

The Network area is depicted on the following page in Figure 6, with the 33kV zone substations shown as blue triangles and the 11kV lines shown in red.

A key implication of Marlborough's sprawling geography means that access to some areas is difficult, with many Sounds areas only accessible by boat or helicopter. Access can be particularly limited or constrained under civil emergency events such as storms, earthquake and major fires.

Marlborough's electricity network conveys energy to 24,750 customer connections with an after-diversity maximum demand of 73MW. MLL's customers are predominantly domestic and small-to-medium commercial customers, with the largest customer representing approximately 3% of total energy volume.

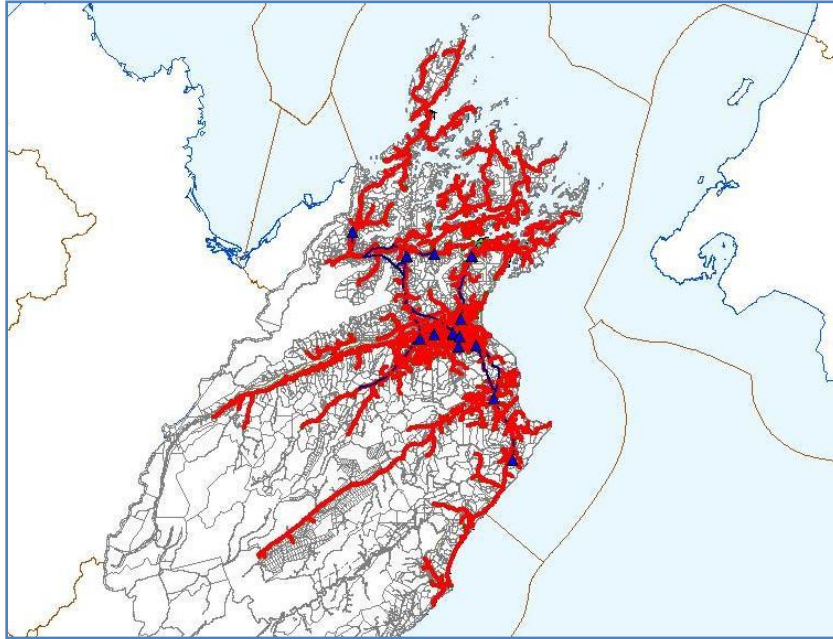

Figure 6 - MLL Network

### 2.1.2 Load Characteristics

During 2014, the Network delivered 370GWh of electricity to 24,750 customers. The peak load was 72.6 MW. The five largest loads collectively used 26.9GWh (7.3% of total) of electricity, while the single largest used 9.2GWh (2.5% of total). These loads are spread across a diverse range of activities from food processing to supermarkets.

### 2.1.3 Large Customers

The nature of Marlborough’s five largest<sup>1</sup> electricity customers are:

| Size | Nature of Business | Nature of Demand           |
|------|--------------------|----------------------------|
| 1    | Primary processing | Constant all year round    |
| 2    | Government agency  | Constant all year round    |
| 3    | Winery             | Cyclic with harvest season |
| 4    | Primary processing | Constant year round        |
| 5    | Winery             | Cyclic with harvest season |

Table 11 - MLL’s Five Largest Customers

Generally the load on the MLL Network consists of a large number of smaller customers and consequently, while the loss of any large load would affect operation of the Network, the affect would be relatively minor compared to the overall effect of changes to the economy, or a decline in one of the significant industries.

<sup>1</sup> Largest by capacity (kW)

For example an overall downturn in the wine industry would have a much greater effect on the operation and development of MLL, than the loss/gain of two or three of the largest customers.

## **2.1.4 Supply Area Characteristics**

MLL provides supply across a diverse area. This can be broken down into the main urban areas of Blenheim and Picton, Marlborough's East Coast, the Marlborough Sounds and the region's inland valleys (Awatere, Waihopai, and Wairau).

### **2.1.4.1 Urban Areas**

Blenheim and Picton contain a mix of residential, commercial and small industrial customers. The maximum demands are predominately a result of winter heating and tend to occur at 7-11 am and 4-8 pm on cold, wet winter nights. In total the towns of Blenheim and Picton represent approximately 60% of the total ICPs and 45% of the load. Note the reason for a lower percentage of the load is that there is a concentration of industrial and larger commercial customers located in the Riverlands industrial estate outside Blenheim.

Residential Load growth is static or falling slightly due to a range of factors including increased use of energy efficient lighting, use of heat pumps rather than conventional heaters etc.

The maximum load on the Riverlands substation is generally a result of wine processing between late March and early May.

### **2.1.4.2 Wairau Plains**

This area includes Woodbourne airbase and airport, the Riverlands industrial estate and a significant horticultural/agricultural area with extensive vineyards. The load tends to be driven by wine processing (late March to early May) and the need for irrigation in the vineyards (December to March).

### **2.1.4.3 Inland Valleys**

While vineyards and, to a lesser degree, dairy farms have moved into these areas, they are still largely pastoral (beef/sheep) with low ICP density. The inland valleys tend to be sheltered from storms and this combined with pastoral land use and MLL's lines being relatively clear of vegetation, makes supply in these valleys fairly reliable, especially given the long lengths of radial feeders.

Pastoral land use combined with some irrigation means that the load tends to peak in the winter months.

#### **2.1.4.4 Marlborough Sounds**

Reticulation in the Marlborough Sounds poses many unique construction and operational challenges. Most of the lines are constructed over rugged terrain, with access to many areas for construction and maintenance limited to foot, tracked vehicles or helicopter. Some areas do not have any road access and can only be accessed by boat and/or on foot. The Marlborough Sounds has a high rainfall and a climate that encourages rapid vegetation growth, leading to the need for tree trimming and vegetation control on a short return basis.

Lines located near the sea coast are subject to salt spray. These lines require higher levels of maintenance, with special provisions required to minimise corrosion damage to conductors, salt build-up on insulators, and spalling on concrete poles. The reticulation includes significant spans across waterways utilised by shipping and these spans are subject to annual surveillance.

MLL has approximately 600km of 11kV distribution lines in the Sounds area, supplying approximately 1,850 customers by way of 15,000kVA of distribution transformer capacity. In the Sounds, there are on average 3.1 customers/km of HV line compared with 10.6 customers/km for the entire Network. Many of the installations are holiday homes with intermittent occupation - approximately 50% of customers use less than 2,000kWh per annum.

These lines have low population density resulting in low load factor and therefore low distribution transformer capacity utilisation. The maximum demands on the various lines supplying the Marlborough Sounds generally occur over long weekends or public holiday periods – Easter, Christmas, Queens Birthday or Labour Weekend. This holiday occupation also leads to much lower diversity of demand than would usually be expected from most areas. In effect, the nature of the load drives demand in the opposite direction to what is desirable i.e. to a poorer load factor.

These various factors increase both the cost of construction and operation/maintenance of the distribution system. They also reduce the overall operating efficiency of the network relative to installed capacity. The situation is exacerbated by the fact that revenue from these customers does not meet the costs incurred and subsidies are required from other customers.

A significant issue facing MLL regarding reticulation in this area is associated with load growth or supply enhancement. Many of the existing lines are built on private or Government-owned land and constructed in the 1960s and 1970s, with access protected by the “existing works” provisions of the Electricity Act. MLL has limited easements over line routes. Therefore, upgrades which necessitate changes to the existing layout or create an injurious affect on the land require new easements to be created. This is a difficult and time-

consuming process. Any future major developments in the Marlborough Sounds area will require very careful analysis and design of both asset and non-asset (e.g. demand control) alternatives to ensure the optimal solutions are found.

In addition, environmental regulations and considerations were generally much less stringent when the lines were built. This is likely to affect the construction of tracks and access to lines, thereby increasing cost.

A further issue with respect to lines in the Marlborough Sounds is that of supply reliability. The various lines supplying sections of the Marlborough Sounds are all radial/spur lines, with no interconnection to other parts of the Network. Invariably because of the undulating nature of the terrain each span is mechanically isolated from the other rather than being on pin insulators. Where binders have failed on pin insulators they have been replaced by clamp tops to improve reliability. Faults on the Network will therefore result in supply being interrupted to customers supplied from that section of the Network until that fault is repaired.

MLL has installed automatic switching devices (sectionalisers, reclosers etc) at various points along each of the radial spurs, to minimise the areas affected by faults to the system. There is however a practical limit to the number of switching devices which can be installed. Over the last year the dedicated SCADA radio system has been expanded and will further increase to enable further remote control of switching closures.

MLL has installed a ground fault neutraliser at its Havelock substation in an endeavour to further reduce loss of supply and has plans for installation of further neutralisers on both the Linkwater and Rai Valley substations which, together with the Havelock substation, supply a significant portion of the Marlborough Sounds.

Many areas in the Sounds are subject to severe windstorms. MLL has an on-going programme of vegetation control in an attempt to minimise interruptions caused by debris such as tree branches being blown across the lines. There are however practical limits to the amount of vegetation control which can be undertaken, particularly given the sensitive environment in which these lines are constructed and the distances that branches can be blown. In some areas the lines have been constructed in environmentally sensitive areas and in others the lines have been surrounded by forestry planted subsequent to the construction of the lines. The company has experienced significant disruption to the network by forestry, especially during harvesting operations or during severe storms when trees are not only blown over but in a number of cases have slid down hillsides. The current tree legislation severely restricts the ability of MLL to proactively remove potential hazards. For example, it only allows trimming of trees in very close proximity to the lines.

It is not realistic to expect that reliability to customers in the Marlborough Sounds area will be the same as that of urban areas. Lines in the Sounds are in a remote location, cannot be duplicated, and are subject to ongoing aging/wear and tear.

Reticulation in the Marlborough Sounds includes the aerial crossings of four navigable waterways with significant spans. Each of these spans has been in service for over 30 years. Because of the arduous environment in which they operate and the frequency of shipping, it was decided to replace the existing conductors and associated hardware. Tory Channel and French Pass crossings were replaced in January/February 2013.

Invariably the reticulation in the Marlborough Sounds has been constructed using treated pine poles because of considerations of weight and resilience to transport, which at the time of installation, were anticipated to have a useful life of 35-40 years. Over recent years, the treated pine poles have been routinely tested and proven to be in good condition. Accordingly MLL now considers their useful lifespan to be 55 years.

During 2011, it was determined that a small batch of poles from a particular manufacturer had failed and approximately 20 poles were replaced to maintain the integrity and reliability of the Network.

Difficult access and the remote location mean that the cost of replacing poles in the Marlborough Sounds is markedly higher than other areas.

In a number of areas the tracks which were utilised for line construction cease to exist and parts of the reticulation can only be serviced by helicopter. The Marlborough Sounds reticulation was constructed to meet the requirements of customers and satisfy government regulation of the day but overall is uneconomic and is subsidised by other customers.

#### **2.1.4.5 East Coast**

The East Coast consists of a narrow strip of coastal land on Marlborough's southern boundary, with some sparsely populated river valleys running into the centre of the South Island. Much of the Network in this area was constructed in the late 1950s using concrete poles and copper conductors. The long radial nature of the area means there are no alternative supplies available during faults or planned outages. The low population density makes it difficult to justify the high levels of expenditure required to provide alternative supplies.

The sheltered nature of the land and pastoral land use, with relatively small areas of trees and vegetation, leads to high reliability of supply in these valleys.

## 2.2 Demographics

At the time of the 2013 Census, MLL's Network area had a normally resident population of about 43,500 people, which was a 2.0% increase from the 2006 Census. Of this population, about 23,000 live within the urban Blenheim area. Key demographic features of MLL's Network area resident population are:

- older than the national average, with a median age seven years greater than the national median, and about 21% of the population aged over 65. (for NZ 14% of the population is aged over 65)
- less educated population than the national average. (13% of people have at least a bachelor's degree, while for NZ 20% have a degree)
- average dwelling occupancy of about 2.5 people per household.
- low deprivation, with phone, mobile phone, internet penetration rates and access the motor vehicles comparable with the national averages.
- significantly lower unemployment than the national average, however the most common occupational class of labouring is almost twice the national average.
- wages slightly lower than the national median across all age groups.
- household spending levels slightly lower than the national median.
- a higher level of home ownership than the national average.
- Lower than average percentage of people born overseas (16% compared to NZ average of 25.2%)
- Less people involved in manufacturing with more people involved in agriculture, forestry and fishing.

The key demographic implications for MLL therefore are: low population growth, lower levels of discretionary spending in the community at large, and an increasing proportion of connected customers shifting to retirement-level incomes.

## 2.3 Key Economic Activities

Marlborough's key economic activities include:

- Food and vegetable processing
- Grape growing and winemaking
- Fishing, shellfish farming and processing
- Pastoral farming
- Dairying
- Forestry
- Timber processing
- Aviation: Woodbourne Air Force base, Safe Air
- Tourism
- Engineering manufacturing



The area's economy is therefore strongly influenced by:

- Markets for customer delicacies such as wine, mussels and salmon
- Changes to the climate that alter grape growth
- Markets for dairy products
- Markets for processed timber
- Government policies on land use, particularly in relation to forestry, climate change and nitrogen-based pastoral farming
- Government policies on major defence installations
- Access to water for crop and stock irrigation
- Algae bloom and rough seas within shellfish farming areas
- The incidence and severity of frosts when grapes are flowering and the extent of rain when grapes are ready for harvest.

The impact of these issues is broadly as follows:

| Issue   | Impact   |
|---|--|
| Shifts in market tastes for wines, mussels and salmon                                       | May lead to an expansion/contraction of demand by these industries. The conversion of pastoral land into vineyards has recommenced after a period of relative inactivity and some significant plantings are scheduled to occur. This has led to increases in demand in areas where electrical load had been static for many years.   |
| Government policy on nitrogen-based farming   | May lead to contraction of dairy shed demand.<br>May lead to contraction of dairy processing demand.   |
| Milk prices   | Higher prices may lead to further conversion of pastoral land to dairying and subsequent increases in demand. Current levels or reduction of prices are unlikely to have much effect unless prices fell to a level where production was uneconomic.  |
| Access to water   | May lead to increased irrigation demand.   |
| Government policy on defence installations.   | Could lead to a significant contraction of demand at a single site, followed by a knock-on decline in disposable income in the community.  |
| Lack of generation and/or electricity supply nationally.                                    | May lead to reductions in demand as alternative energy sources are more widely utilised.   |
| Increase in distributed generation including photovoltaic installation of customer premises | MLL currently has the second highest uptake of photo voltaics on a per customer basis. This trend can be expected to continue especially as the costs reduce. This has the potential to diminish the energy transported over the network and ultimately may well necessitate changes to the company's pricing structure to ensure equity and fairness by greater recovery of costs on a fixed or capacity basis. |

Table 12 - Impact of Key Economic Activities

## 2.4 Other Drivers of Electricity Use

Other drivers of electricity use include:

- Low inland temperatures during winter. Minus five degree frosts are common in many areas beyond the lower Wairau River plain.
- The use of heat pumps as air conditioners in the summer time.
- Increased utilisation of electricity, as polluting sources of energy, such as coal and wood are replaced.

### 2.4.1 Disruptive Technologies

Marlborough Lines is part of a national group considering the impact of disruptive technologies and the manner in which network assets will be operated and managed in the future.

Key disruptive technologies being considered are:

- **Distributed Generation**, e.g. Photo Voltaic/Solar and Wind – The reduction in the cost of PV systems and increased interest in this is resulting in significant increases in the number of PV installations. This is likely to continue. Because of the lack of diversity and the intermittent nature of this type of generation, it is likely this will increase the voltage swings in the Network and lead to the need to reinforce the network, in particular the LV Network.
- **Electric Vehicles** – The Transportation sector utilises a significant amount of energy. A move towards to greater use of electric vehicles will affect both the need for generation and the electrical networks which distribute it. One of the key factors with electric vehicles is the current cost and capacity of batteries.
- **Battery Technology** – This is an important factor in both Electric Vehicles and in the uptake of PV. Low cost batteries will enable some installations to become independent of the Electrical Network, and provide others with a means to store the generation and use it at times which produce maximum benefit.

There are a number of ways that networks can adapt to these technologies. The use of 'smart' networks, i.e. principally gathering more accurate information and therefore getting more and better use out of existing assets is a one option being looked at. It should be noted that doing this provides a number of benefits even in the absence of any disruptive technologies.

It is generally that the factors driving the uptake of the above technologies will not result in need for major change in Asset Management Practices within the period of this AMP, however MLL will continue to look at the technologies and consider how they might affect the ways in which the Network can best be managed to give maximum benefit to all stakeholders. MLL does not anticipate any difficulty meeting requirements of electric vehicles when demand commences.

## 2.5 Description of Network Configuration

### 2.5.1 Overview

Supply to the region is provided by three 110kV Transpower lines. The Blenheim Grid Exit Point (GXP) has three 110kV/33kV capacity of 100 MVA transformers supplying three 33kV buses. This gives a n-1 capacity of 100MVA. From the Transpower 33kV circuit breakers, the 33kV sub-transmission Network distributes supply to the 33/11kV zone substations.

The 33/11kV zone substations transform the voltage level down to 11kV. Each of the 16 zone substations has between two and six 11kV feeders radiating outwards, with some meshing possible in urban areas. These feeders collectively supply 3,830 distribution transformers that range from pole-mounted 5kVA units to ground-mounted 1,000kVA units. In turn, each distribution transformer has a number of 400V feeders radiating outwards, again with some meshing possible in urban areas.

The majority of customers take supply at 230/400V, with eight of our larger customers taking supply at 11kV.

### 2.5.2 Transpower Point of Supply/Transmission Lines

MLL has a single Transpower GXP in Blenheim (on the corner of Murphys and Old Renwick Roads) where supply from the national grid enters MLL's Network. Blenheim's GXP is currently supplied by three separate Transpower-owned 110kV circuits, one from Kikiwa and two from Stoke. The Kikiwa line is an "H" structure hardwood pole line, although a number of structures have been replaced with PSC poles. This line has a summer rating of 56MVA, and winter rating of 68MVA.

There are two Stoke-Blenheim 110kV circuits installed on the same towers. These circuits are rated at 76MVA for the original circuit and 105MVA for the circuit added in 2005.

The 110/33kV transformer capacity at Blenheim GXP consists of two banks of three single phase 50MVA units and a third 60MVA three phase unit. The 60MVA unit was commissioned in January 2011.

The bulk supply characteristics are summarised below:

| GXP      | Demand                              | Voltage  | GXP Rating  |              | Line Rating |              |
|----------|-------------------------------------|----------|-------------|--------------|-------------|--------------|
|          |                                     |          | (n) rating  | (n-1) rating | (n) rating  | (n-1) rating |
| Blenheim | 70 MVA, controllable to about 64MVA | 110/33kV | 160/172 MVA | 100/112 MVA  | 189/202 MVA | 110/136 MVA  |

Table 13 - Blenheim GXP

Changes to the Transpower charging scheme mean that MLL's peak charges are based on its contribution to the 12 highest upper South Island Coincident Peaks. MLL works constructively with other Lines Companies in the upper South Island to

manage the Upper South Peak. Changes were made to MLL's load control system and those of other upper South Island Lines Companies to allow control based on upper South Load. This system has been successfully used from 2010 to the present day. This is especially because MLL's maximum demand is typically in April rather than at the time of most other network companies during winter months.

### 2.5.3 Embedded Generation

TrustPower operates a 2.4MW 'run-of-river' generator at Waihopai which is embedded into MLL's 33kV Network. This plant was originally built in 1927 by the Marlborough Electric Power Board and upgraded by MLL's predecessor, Marlborough Electric in 1999. Output of this generator is dependent on rainfall in the catchment area.

Energy 3 has two wind farms: at Weld Cone, near MLL's Ward substation there are three 250kW turbines, while at Lulworth just north of the Ure River, four 260kW turbines are installed. The units at Weld Cone began generation in February 2010 and the Lulworth units commenced in January 2011. Both schemes are embedded into MLL's Network.

Dominion Salt have installed a 600kW wind turbine which is embedded into their 11kV installation.

The potential wind resource in the Marlborough Sounds and on the East Coast is significant, however the development of substantial wind farms will require construction of new lines to convey the output to load centres.



Photo 7 - Lulworth Wind Generation

TrustPower operates the Branch Power Scheme and has been granted resource consent to extend this scheme. Six new power stations are proposed with one connecting to the existing Branch scheme infrastructure, four connecting to a new substation on the 110 kV Kikiwa to Blenheim line and one connecting to MLL's existing Network in the Wairau Valley. MLL understands that TrustPower does not currently intend to proceed with construction of the scheme.

The Wairau Hospital and a number of wineries and local businesses have small diesel generators which are used for load management and emergency power supply. Some of these units are capable of embedded operation.

The current low cost of photovoltaic cells has seen an increase in interest in small scale solar distributed generation. At the time of writing, there were 133 small solar installations, two installations with solar and wind, 1 small hydro, 3 large solar and 18 installations with embedded diesel generators. In 2012 there were 12 small solar installations.

There has been discussion concerning tidal power generators at the entrance to Tory Channel, however no resource consent has yet been applied for, and this type of generation is relatively unproven. The cost, efficiency and environmental impacts to the seabed and marine environment have yet to be accurately determined.

Utilisation of this resource would require the construction of a new transmission line from Tory Channel to a load centre.

Embedded generation produced 15.3 GWh in the 2012 year, 15.0 GWh in the 2013 and 14.0 GWh in 2014. This is mainly from the Waihopai scheme and larger wind farms. The variations in output are mainly due to changes in rainfall.

In practical terms the current possibility of significant tidal generation in Tory Channel is slim.

#### **2.5.4 Sub-transmission System**

The Transpower substation has three 110kV/33kV transformers supplying three 33kV buses. From the Transpower substation, Marlborough Lines' 33kV sub-transmission Network distributes supply to MLL's 33/11kV zone substations. The 33kV sub-transmission Network uses radial duplicated feeders and provides n-1 security of supply to the 33kV bus at all zone substations, except Rai Valley, Linkwater and Ward. About 4% of the 33kV Network is underground. MLL has 16 zone substations throughout its Network area, with four zone substations supplying Blenheim.

Of a total 301km of 33kV line, 286km is overhead, most of which has been constructed since 1960. Lines constructed earlier than 1960 include galvanised tower lines between Waihopai Power Station and Renwick and part of the line between Riverlands and Seddon.

The Blenheim/Waihopai line was commissioned in 1927 to transfer electricity from the Waihopai hydro-generation station to Blenheim. Much of this line remains unaltered from its original construction, although some sections have been rebuilt to allow road widening and extra mid-span poles have been inserted to allow connection of 11kV spur lines and transformers. The aluminium conductor is mostly original, but with the addition of pre-formed line splices over each insulator to repair any conductor strand breakage. In 2005, below-ground deterioration was detected on a proportion of the towers between Waihopai and Blenheim and these have been replaced. Work is currently planned on the first section of towers in the Waihopai valley.

In the early 1970s, a double circuit 33kV and 11kV line was constructed between Okiwi Bay and Elaine Bay in the Marlborough Sounds, using a high proportion of

larch poles treated with creosote. These poles are at the end of their useful lives and are being progressively replaced.

The two figures below show the overall 33kV sub transmission system (blue lines) together with zone substations and embedded generation (circles with a red centre).

A single line diagram is included in appendix E.

All new 33kV line construction in rural areas is currently being insulated at 66kV or 110kV.

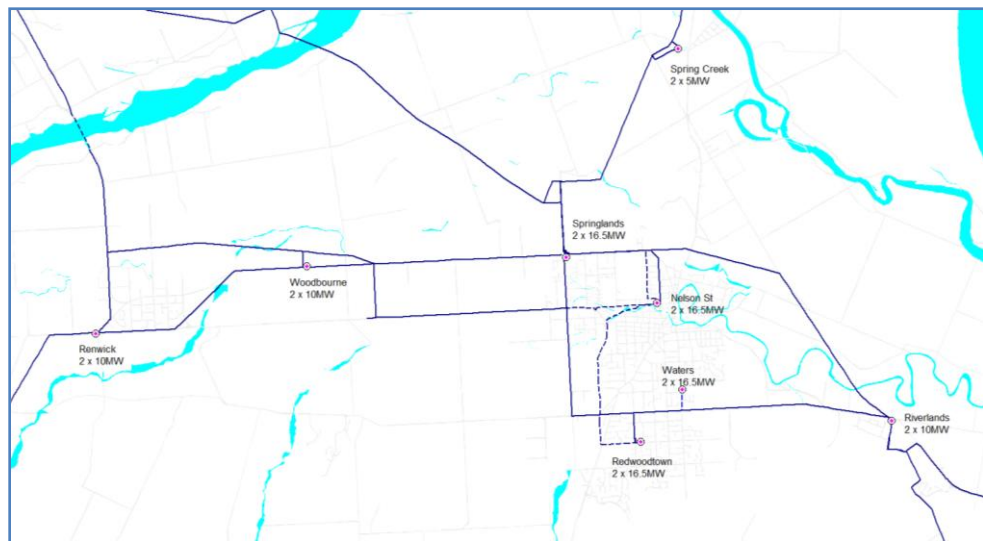

Figure 7 - Central 33kV Sub-transmission

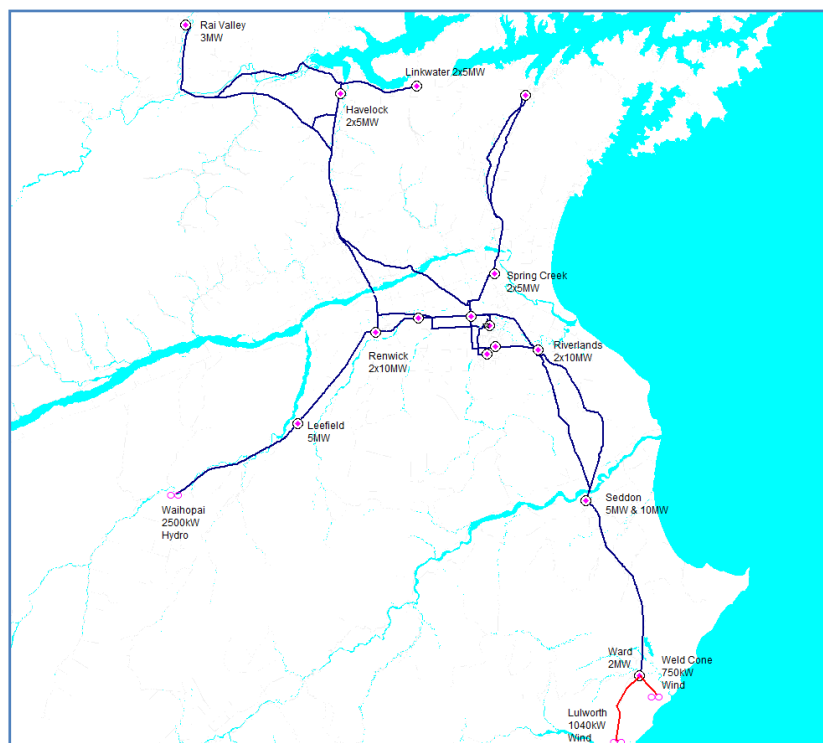

Figure 8 - 33kV Sub-transmission System

### 2.5.5 Zone Substations

Zone substations transform the 33kV down to 11kV for reticulation to 11kV/400V transformers. All of the zone substations are equipped with on-load tap changers and automatic voltage regulators to regulate the 11kV supply and maintain constant voltage.

The major components of the substations are transformers and switchgear.



Photo 8 - Waters Substation, Blenheim

## 2.5.6 2014 Zone Substation Loadings

| Substation    | T1 Capacity (MVA) | T2 Capacity (MVA) | Maximum Demand (MVA) | Average Load (MVA) | Notes   |
|---------------|-------------------|-------------------|----------------------|--------------------|---|
| Leefield      | 5                 |                   | 1.1                  | 0.4                |   |
| Linkwater     | 5                 | 5                 | 3.7                  | 1.1                | Holiday homes with low occupancy over winter  |
| Havelock      | 5                 | 5                 | 4.0                  | 1.4                |   |
| Nelson Street | 15                | 15                | 14.6                 | 6.3                |   |
| Picton        | 15                | 15                | 6.7                  | 3.6                |   |
| Rai Valley    | 3                 | 5                 | 1.9                  | 0.8                |   |
| Redwoodtown   | 15                | 15                | 10.3                 | 4.5                |   |
| Renwick       | 10                | 10                | 9.5                  | 5.0                |   |
| Riverlands    | 10                | 10                | 9.5                  | 3.6                | Still experiencing strong growth during wine making period, load being moved to Cloudy Bay                        |
| Seddon        | 10                | 5                 | 5.3                  | 2.3                |   |
| Spring Creek  | 5                 | 5                 | 4.0                  | 2.2                |   |
| Springlands   | 15                | 15                | 10.4                 | 5.3                |   |
| Ward          | 2                 | 2                 | 1.7                  | 0.6                | The maximum loading on the transformers occurs when the load is low and the wind farms are producing full output. |
| Cloudy Bay    | 15                | 15                | 4.2                  | 1.3                |   |
| Waters        | 15                | 15                | 6.8                  | 2.9                |   |
| Woodbourne    | 10                | 10                | 7.7                  | 3.8                |   |

**Table 14 - Zone Substation Loadings**

Note load graphs are contained in appendix C.

MLL has acquired three sites for three future substations. Their construction will potentially transfer load from substations in the Renwick/Blenheim areas and will be constructed to meet customer demand.

Consistent with its planning horizon MLL has recognised the potential need for the sites and that opportunities to purchase substation sites are limited. Accordingly, the sites have been purchased and typically have significantly escalated in value.



### 2.5.7 Distribution System

Marlborough Lines Ltd operates an 11kV distribution Network which is largely radial with some meshing in urban and higher density rural areas. About 6% of the 11kV (by line length) is underground.

Lightning protection is generally installed on all under-ground to overhead transitions and in areas prone to lightning.

All new 11kV lines in rural areas are being insulated at 22kV to allow for future increases in supply voltage.

### 2.5.8 Distribution Substations

MLL has 3900 distribution substations. Of these, 445 are ground mounted and the remainder are pole mounted. All transformers greater than 300kVA are ground mounted and in general smaller transformers are pole mounted.

Key features of MLL's distribution substations include:

- typically 200kVA or 300kVA in urban areas.
- fused on the HV side.
- LV cables with HRC fuses.
- LV typically runs along both sides of the street i.e. no multiple service lines crossing the street.
- LV runs are typically limited to a maximum of 350m to reduce incidences of low voltage.

In rural areas, 11kV lines are generally built with 80-100m pole spacings on the flat and greater distances depending on terrain. These distances make the installation of LV impractical in many situations and, combined with a low density of customers, necessitate many rural customers having their own transformers. This results in a lower coefficient of utilisation than would be achieved with fewer transformers, closer pole spacing and more LV conductor run, however it is the most cost effective solution to supply voltage at regulatory levels.

### 2.5.9 Low Voltage Network

MLL operates a 400V (LV) reticulation Network with significant meshing in urban areas. About 41% of the LV is underground. As noted above, in general in many rural areas, pole spacing and customer locations result in customers having individual transformers and correspondingly, less use of LV conductor.

MLL has 775 km of low voltage Network.

### 2.5.10 Ripple Control, SCADA and Communications

MLL operates 217Hz and 1050Hz ripple injection systems. These both inject at 33kV with the injection equipment installed at the Springlands substation site. All

ripple relays are owned by the energy retailers. The 1050Hz equipment was originally installed in 1967. All new ripple relays are at 217Hz.

SCADA covers all of the zone substations, voltage regulators and 33kV reclosers. This system allows staff to monitor and control the Network.

Communication for the SCADA consists of dedicated radio equipment, as well as use of internet and cellphones. To ensure greater reliability in the event of major civil emergencies or wide spread power outages, the SCADA radio network is being extended.

MLL also operates a voice radio network which covers the whole region. This is used for operational control of the Network.



**Photo 9 SCADA Controlled 11kV recloser**

## 2.6 Asset Categories

### 2.6.1 Major Asset Groups

| Type                                      | Number   | Average Age (years) 31/3/2014 | Regulated asset Base \$000 |
|---|----------|-------------------------------|----------------------------|
| Subtransmission Lines                     | 284 km   | 34.5                          | 17,376                     |
| Subtransmission Cables                    | 17.5 km  | 7.9                           | 7,477                      |
| Zone Substations                          |          |                               | 34,923                     |
| Buildings                                 | 16       | 15.5                          |                            |
| Switchgear                                | 296      | 9.8                           |                            |
| Transformers                              | 30       | 20.3                          |                            |
| Distribution and LV Lines                 | 2570 km  | 34.2                          | 48,081                     |
| Distribution and LV Cables                | 173.1 km | 12.5                          | 46,083                     |
| Distribution substations and transformers | 3827     | 23.1                          | 23,663                     |
| Distribution Switchgear                   | 2424     | 12.0                          | 16,613                     |
| Other Network assets                      |          |                               | 5,847                      |
| Non Network assets                        |          |                               | 14,962                     |
|   |          |                               | <b>215,025</b>             |

Table 15 - Major Classes of Assets

The values shown above are based on the Regulated Asset Base as at 31/3/2014 and the data contained in the Information Disclosure for 2014.

### 2.6.2 Asset Lives

The ODV handbook assigns maximum lives of 45 years for wooden poles and 60 years for concrete poles. The experience in Marlborough is that poles (in particular treated pine and concrete) last much longer than this. However, hardwood poles, including larch, are starting to deteriorate, and 45 years seems a reasonable estimate of useful life for these poles.

Concrete poles are showing little, if any, signs of aging. In the last ten years, there have been fewer than 10 concrete pole failures and/or replacement due to signs of aging out of a total population of approximately 15,000. Most of the failures have been due to adverse environment, e.g. salt spray on concrete poles or external damage.

For concrete poles, 70 years is a conservative estimate, which may be extended as poles age and more data on actual failures is obtained.

Until recently, treated pine poles have shown few signs of aging. Continuous monitoring has revealed that one batch of poles (approximately 100) installed in

1969 has reached the end of its life. It is considered that this is due to a failure of treatment process rather than a systemic problem.

Accordingly it is considered that a life of 55 years for treated pine poles is still realistic.

Lines built in 1927 on steel towers are still in service, however some sections of the original lines have now been upgraded to steel poles. Further renewal will occur within the period of this AMP.

### **2.6.3 Poles**

Poles are a major component of overhead lines. To a large extent, the condition of the poles determines whether a line needs to be replaced or can be maintained or upgraded unless in some instances additional capacity is required.

The Network has been constructed on a variety of different pole types. Current practice is to utilise pre-stressed concrete poles where good access is available, and treated pine in other areas. Where large spans of heavy conductors are required tubular steel poles are utilised. Since 1969 almost all of the lines constructed in the Marlborough Sounds have been on treated pine poles due to the difficult access tracks or the need to fly the poles to site by helicopter. Creosote-treated larch poles were used in the period 1971 to 1983. Iron rails have been used for minor works throughout the Network. In total MLL owns 30,487 poles.

The breakdown of pole types used today is shown in the table below. Note some poles carry a mixture of voltage lines e.g. 33kV and 11kV. Poles have been classified according to the highest voltage carried.

| Type                   | Voltage | Number       | Age (years) | Average Condition<br>(4=new, 1=close to failure) | Fair/poor condition | Red tags   | Notes  |
|------------------------|---------|--------------|-------------|--|---------------------|------------|--|
| Galv Steel Column      | 33000   | 312          | 5.1         | 3.7  | 17                  |            | new, excellent condition   |
| Hardwood               | 33000   | 28           | 55.9        | 2.8  | 4                   | 1          | need renewal, program for replacement .  |
| Larch                  | 33000   | 4            | 41.3        | 1.5  | 3                   | 3          | need renewal, program for replacement .  |
| Pre-Stressed Concrete  | 33000   | 1190         | 30.9        | 3.2  | 2                   |            | good condition   |
| Reinforced Concrete    | 33000   | 823          | 48.4        | 3.0  | 12                  |            | older but good condition   |
| Tanalised Pine         | 33000   | 185          | 36.7        | 3.0  | 4                   |            | good condition, being actively monitored                                       |
| Tower Galvanised Steel | 33000   | 205          | 69.1        | 3.0  | 2                   |            | some renewal   |
| Galv Steel Column      | 11000   | 23           | 3.2         | 3.8  |                     |            | new, excellent condition   |
| Hardwood               | 11000   | 47           | 46.3        | 2.8  | 11                  | 3          | fair/good condition  |
| Iron Rail              | 11000   | 1566         | 50.1        | 3.0  | 48                  | 3          | EEA guide recommends no climbing. Will need renewal                            |
| Larch                  | 11000   | 161          | 35.8        | 2.3  | 111                 | 7          | At end of life. Need renewal   |
| Pre-Stressed Concrete  | 11000   | 5425         | 19.6        | 3.2  | 8                   |            | good condition   |
| Reinforced Concrete    | 11000   | 6038         | 52.2        | 3.0  | 80                  |            | older but good condition   |
| Tanalised Pine         | 11000   | 7497         | 30.1        | 3.0  | 61                  | 3          | good condition, being actively monitored                                       |
| Tower Galvanised Steel | 11000   | 8            | 42.8        | 3.4  |                     |            | some renewal   |
| Hardwood               | 0415    | 198          | 53.0        | 2.7  | 65                  | 3          | need renewal   |
| Iron Rail              | 0415    | 294          | 57.1        | 2.9  | 16                  |            | EEA guide recommends no climbing. Will need renewal, program for replacement . |
| Larch                  | 0415    | 67           | 42.9        | 2.8  | 16                  |            | need renewal   |
| Pre-Stressed Concrete  | 0415    | 846          | 24.4        | 3.2  | 1                   |            | good condition   |
| Reinforced Concrete    | 0415    | 1910         | 48.3        | 3.0  | 9                   |            | older but good condition   |
| Tanalised Pine         | 0415    | 2573         | 39.5        | 3.0  | 13                  |            | good condition, being actively monitored                                       |
| <b>Total</b>           |         | <b>29400</b> | <b>39.7</b> | <b>3.0</b>                                       | <b>483</b>          | <b>*23</b> |  |

**Table 16 - Pole Types Used**

*\*This total is that which prevails at the time of the production of this report but will have been revised by the time of the report's publication.*

Any poles assessed as a hazard are red tagged and dealt with as soon as practical.

Regular monitoring of the condition of all poles is undertaken. Wooden poles which are older than 5 years are having their condition assessed using non-destructive testing. More information on this is given in the section on Lifecycle Planning,

Poles which are of the greatest concern are hardwood poles and iron rails and, in particular, those carrying 11kV or 33kV lines, as these affect the greatest number

of customers. All poles identified as potential problems/safety hazards will be replaced irrespective of type and location.

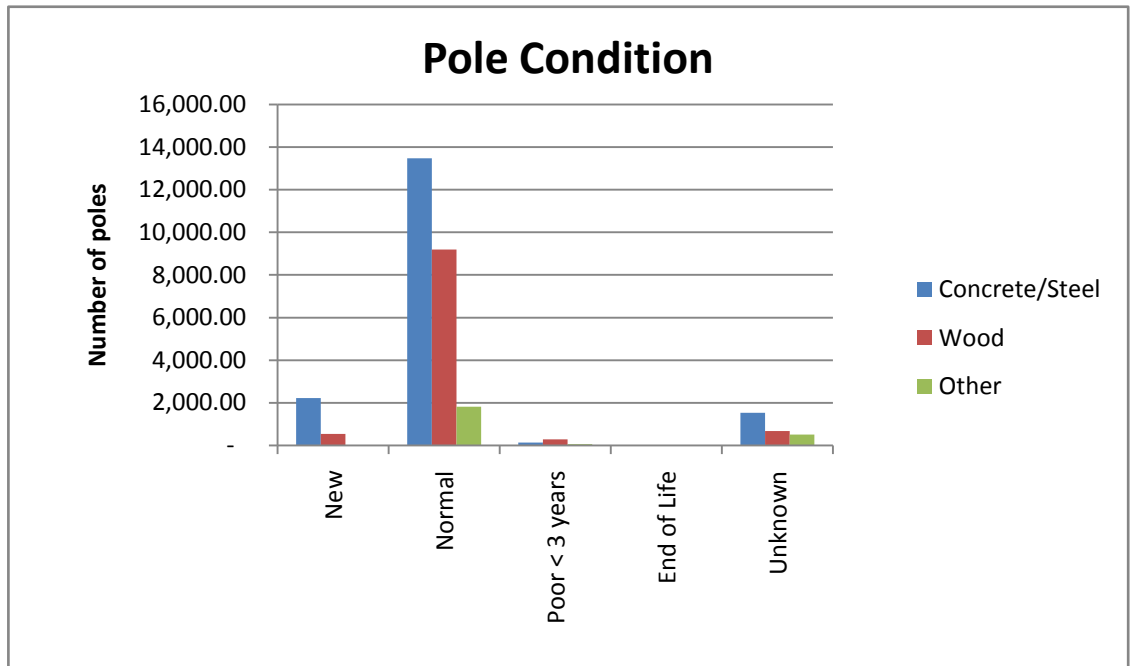

Figure 9 - Pole Condition

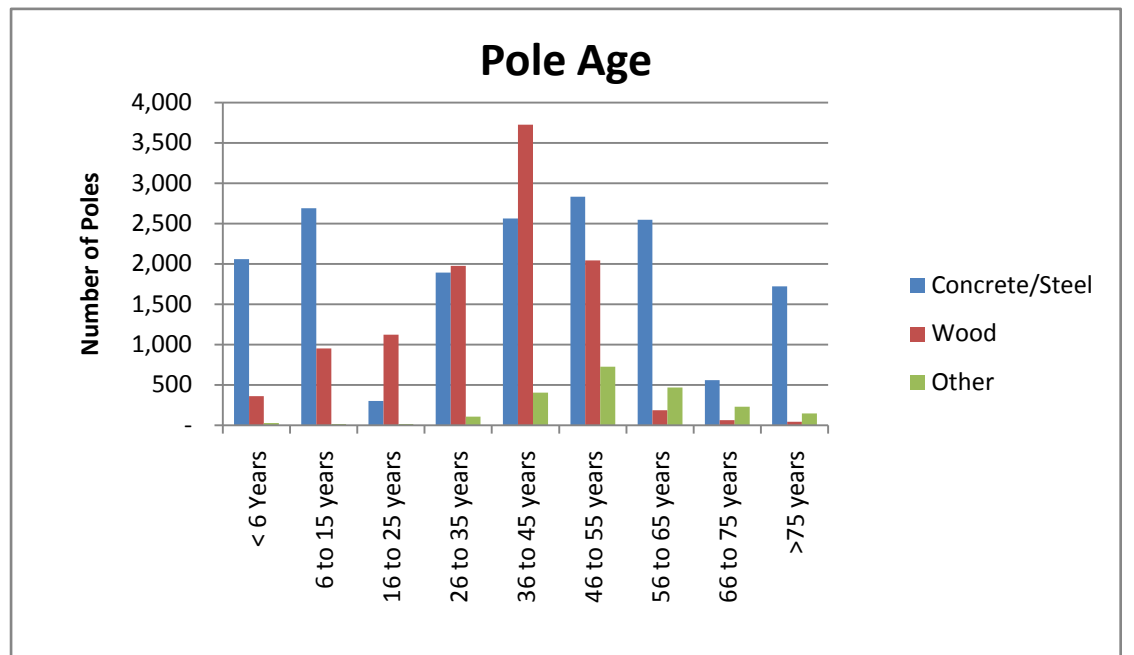

Figure 10 - Pole Age

### 2.6.4 Bulk Supply Points

MLL has very few assets located within the Blenheim GXP. The demarcation point between the MLL Network and the Transpower-owned equipment is the outgoing terminals on the circuit breakers, hence the outgoing cables are part of the MLL Network. In addition MLL has two control panels located within the GXP. These

house check -metering equipment and a SCADA RTU which allows monitoring and ultimately operational control of the 33kV circuit breakers. A second cabinet allows for the future provision of differential protection on the 33kV cable supplies.

This equipment is all less than four years old.

## 2.6.5 Sub-transmission Network

### 2.6.5.1 33kV Lines Overhead

There are 280 km of 33kV overhead lines, with an average age of 34.5 years compared with an expected average useful life of 69 years. The RAB of the 33kV overhead is \$17.4 million.

The age profile of the 33kV overhead lines is shown below.

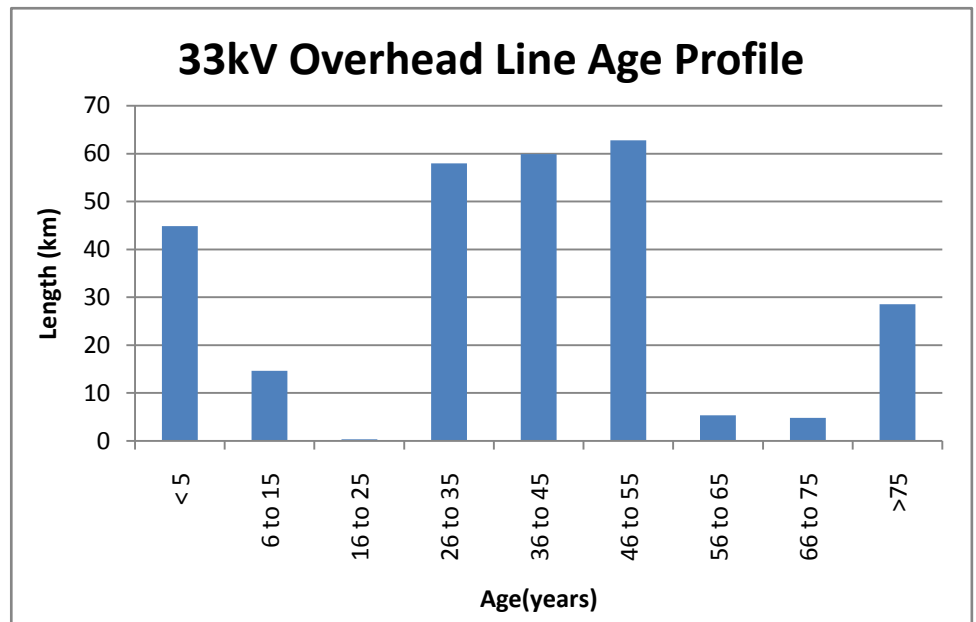

Figure 11 - 33kV Line Age Profile

Around 20% of the existing 33kV Network is currently older than the maximum life provided in the ODV handbook.

Extensive monitoring is carried out on the 33kV lines and in general, the condition of the 33kV lines is very good. In total there are 29km of the original 1926 33kV line still in service. Investigation has shown that the original 1926 33kV towers near bitumen roadways have significant corrosion just below ground level. These have been strengthened and/or replaced.

The 14.5km section of 1926 33kV line from Leefield substation to the Waihopai Dam services the embedded generation station. Redwood Pass contains 6.5km of the original 33kV 1926 tower line, and the remaining 8km is located between Renwick substation and Leefield substation.

The 1956 hardwood 'Cobb' 33kV line has now been renewed.

Data on the pole types and pole condition for the 33kV lines is contained in section 2.6.3.

### 2.6.5.2 **33kV Underground**

The 33kV sub-transmission cable underground assets are relatively new, as shown below. The total length of cable is 17.5km and the average age is eight years compared with an expected life of 45 years. The RAB value of the cable is \$7.5 million.

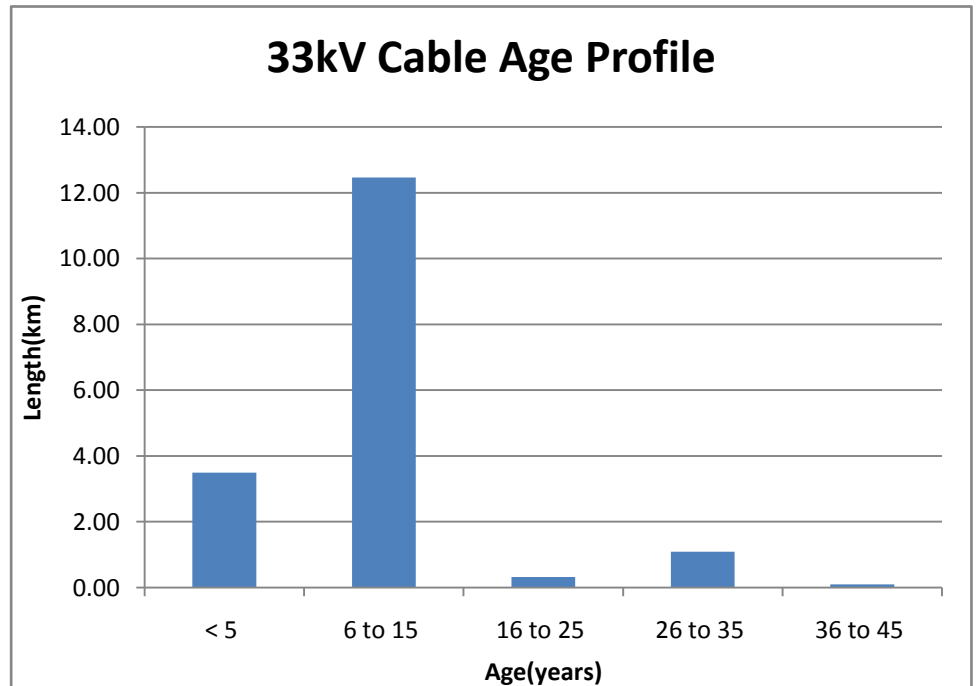

Figure 12 - 33kV Cables Age Profile

All of this cable will be less than 45 years old in 2025, and hence will not need renewal within the period of this AMP.

### 2.6.6 **33/11kV Zone Substation Transformers**

The RAB value of the Zone substations is \$34.9 million of which approximately half is the value of the 33/11kV transformers.

Based on the expected life of 55 years, five transformers are due for renewal within the next ten years. The cost of replacing these transformers is relatively small yet will reduce overall transformer's age and reduce risk of failure. Because of the importance of the transformers they are carefully monitored and inspected and have regular maintenance and testing. The Woodbourne T1 transformer failed in 2011 at an age of 45 years, however this is considered to be an anomaly.



Zone substations are all monitored by SCADA. Monthly inspections are undertaken to ensure the integrity of the site and equipment. DGA testing is undertaken every 12-18 months. A summary of the 2014 DGA tests is shown below. The next round of testing will occur in mid-2015. Note that items in ***bold italics*** are those which require maintenance and/or re-inspection within the next year.

| Location      | Year | MVA  | TCA | Transformer Condition  | TASA | Tap Changer Condition  |
|---------------|------|------|-----|--|------|--|
| Cloudy Bay T1 | 2012 | 16.5 | 1   | No abnormal gas generation is indicated. Fluid condition is within acceptable in-service parameters. Paper condition is "as new" (based on furan levels)                                   | 1    | LTC is operating satisfactorily. No special actions are recommended.   |
| Cloudy Bay T2 | 2012 | 16.5 | 1   | No abnormal gas generation is indicated. Fluid condition is within acceptable in-service parameters. Paper condition is "as new" (based on furan levels)                                   | 1    | LTC is operating satisfactorily. No special actions are recommended.   |
| Havelock T1   | 1974 | 5    | 1   | <b><i>Arcing is indicated. Tap-changer communication likely cause. Fluid Oxidation is advancing. Paper condition is reduced to 80% tensile strength.</i></b>                               | 2    | <b><i>Slightly abnormal dissipation of energy is noted. This is an early indication of fault or wear activity. Recommend retest within 150 days (5 months) for trending.</i></b> |
| Havelock T2   | 1972 | 5    | 1   | No abnormal gas generation is indicated. Fluid condition is within acceptable in-service parameters. Paper condition is reduced to 50% tensile strength                                    | 2    | <b><i>Slightly abnormal dissipation of energy is noted. This is an early indication of fault or wear activity. Recommend retest within 150 days (5 months) for trending.</i></b> |
| Leefield T1   | 1966 | 5    | 1   | <b><i>Arcing is indicated. Tap-changer communication likely cause. Fluid condition is within acceptable in-service parameters. Paper condition is reduced to 70% tensile strength.</i></b> | 2    | <b><i>Slightly abnormal dissipation of energy is noted. This is an early indication of fault or wear activity. Recommend retest within 150 days (5 months) for trending.</i></b> |
| Linkwater T1  | 1984 | 5    | 1   | <b><i>Arcing is indicated. Tap-changer communication likely cause. Fluid condition is within acceptable in-service parameters. Paper condition is "as new" (based on furan levels)</i></b> | 1    | LTC is operating satisfactorily. No special actions are recommended.   |
| Linkwater T2  | 1984 | 5    | 1   | <b><i>Arcing is indicated. Tap-changer communication likely cause. Fluid condition is within acceptable in-service parameters. Paper condition is "as new" (based on furan levels)</i></b> | 1    | LTC is operating satisfactorily. No special actions are recommended.   |
| Nelson St T1  | 2007 | 16.5 | 1   | No abnormal gas generation is indicated. Fluid condition is within acceptable in-service parameters. Paper condition is "as new" (based on furan levels)                                   | 1    | LTC is operating satisfactorily. No special actions are recommended.   |

| Location       | Year | MVA  | TCA | Transformer Condition  | TASA | Tap Changer Condition  |
|----------------|------|------|-----|--|------|--|
| Nelson St T2   | 2007 | 16.5 | 1   | No abnormal gas generation is indicated. Fluid condition is within acceptable in-service parameters. Paper condition is "as new" (based on furan levels) | 1    | LTC is operating satisfactorily. No special actions are recommended.   |
| Picton T1      | 2006 | 16.5 | 1   | No abnormal gas generation is indicated. Fluid condition is within acceptable in-service parameters. Paper condition is "as new" (based on furan levels) | 1    | LTC is operating satisfactorily. No special actions are recommended.   |
| Picton T2      | 2005 | 16.5 | 1   | No abnormal gas generation is indicated. Fluid condition is within acceptable in-service parameters. Paper condition is "as new" (based on furan levels) | 1    | LTC is operating satisfactorily. No special actions are recommended.   |
| Rai Valley T1  | 1961 | 3    | 1   | No abnormal gas generation is indicated. Fluid condition is within acceptable in-service parameters. Paper condition is reduced to 70% tensile strength  | 2    | <b><i>Slightly abnormal dissipation of energy is noted. This is an early indication of fault or wear activity. Recommend retest within 150 days (5 months) for trending.</i></b> |
| Rai Valley T2  | 2013 | 5    | 1   | No abnormal gas generation is indicated. Fluid condition is within acceptable in-service parameters. Paper condition is "as new" (based on furan levels) | 1    | LTC is operating satisfactorily. No special actions are recommended.   |
| Redwoodtown T1 | 2005 | 16.5 | 1   | No abnormal gas generation is indicated. Fluid condition is within acceptable in-service parameters. Paper condition is "as new" (based on furan levels) | 1    | LTC is operating satisfactorily. No special actions are recommended.   |
| Redwoodtown T2 | 2005 | 16.5 | 1   | No abnormal gas generation is indicated. Fluid condition is within acceptable in-service parameters. Paper condition is "as new" (based on furan levels) | 1    | LTC is operating satisfactorily. No special actions are recommended.   |
| Renwick T1     | 1995 | 10   | 1   | No abnormal gas generation is indicated. Fluid condition is within acceptable in-service parameters. Paper condition is "as new" (based on furan levels) | 1    | LTC is operating satisfactorily. No special actions are recommended.   |
| Renwick T2     | 1997 | 10   | 1   | No abnormal gas generation is indicated. Fluid condition is within acceptable in-service parameters. Paper condition is "as new" (based on furan levels) | 1    | LTC is operating satisfactorily. No special actions are recommended.   |
| Riverlands T1  | 1982 | 10   | 1   | No abnormal gas generation is indicated. Fluid condition is within acceptable in-service parameters. Paper condition is                                  | 2    | <b><i>Slightly abnormal dissipation of energy is noted. This is an early indication of fault or wear activity. Recommend retest within 150 days</i></b>                          |

| Location        | Year | MVA  | TCA | Transformer Condition  | TASA | Tap Changer Condition  |
|-----------------|------|------|-----|--|------|--|
|                 |      |      |     | "as new" (based on furan levels)   |      | <i>(5 months) for trending.</i>  |
| Riverlands T2   | 1962 | 10   | 1   | No abnormal gas generation is indicated. Fluid condition is within acceptable in-service parameters. Paper condition is reduced to 80% tensile strength      | 1    | LTC is operating satisfactorily. No special actions are recommended.   |
| Seddon T1       | 2001 | 10   | 1   | No abnormal gas generation is indicated. Fluid condition is within acceptable in-service parameters. Paper condition is "as new" (based on furan levels)     | 2    | <b><i>Slightly abnormal dissipation of energy is noted. This is an early indication of fault or wear activity. Recommend retest within 150 days (5 months) for trending.</i></b> |
| Seddon T2       | 2012 | 10   | 4*  | <b><i>Arcing is Indicated. Retest to confirm</i></b>   | 1    | LTC is operating satisfactorily. No special actions are recommended.   |
| Spring Creek T1 | 1985 | 5    | 1   | No abnormal gas generation is indicated. Fluid condition is within acceptable in-service parameters. Paper condition is "as new" (based on furan levels)     | 1    | LTC is operating satisfactorily. No special actions are recommended.   |
| Spring Creek T2 | 1987 | 5    | 1   | No abnormal gas generation is indicated. Fluid condition is within acceptable in-service parameters. Paper condition is "as new" (based on furan levels)     | 1    | LTC is operating satisfactorily. No special actions are recommended.   |
| Springlands T1  | 2005 | 16.5 | 1   | No abnormal gas generation is indicated. Fluid condition is within acceptable in-service parameters. Paper condition is "as new" (based on furan levels)     | 1    | LTC is operating satisfactorily. No special actions are recommended.   |
| Springlands T2  | 2005 | 16.5 | 1   | No abnormal gas generation is indicated. Fluid condition is within acceptable in-service parameters. Paper condition is "as new" (based on furan levels)     | 1    | LTC is operating satisfactorily. No special actions are recommended.   |
| Ward T1         | 1959 | 2    | 1   | <b><i>Arcing is indicated. Tap-changer communication likely cause. Fluid Oxidation is advancing. Paper condition is "as new" (based on furan levels)</i></b> | 1    | LTC is operating satisfactorily. No special actions are recommended.   |
| Ward T2         | 1960 | 2    | 1   | No abnormal gas generation is indicated. Fluid condition is within acceptable in-service parameters. Paper condition is "as new" (based on furan levels)     | 1    | LTC is operating satisfactorily. No special actions are recommended.   |
| Waters T1       | 2009 | 16.5 | 1   | No abnormal gas generation is indicated. Fluid condition is within acceptable in-service parameters. Paper condition is "as new" (based on furan levels)     | 1    | LTC is operating satisfactorily. No special actions are recommended.   |

| Location      | Year | MVA  | TCA | Transformer Condition  | TASA | Tap Changer Condition  |
|---------------|------|------|-----|--|------|--|
| Waters T2     | 2009 | 16.5 | 1   | No abnormal gas generation is indicated. Fluid condition is within acceptable in-service parameters. Paper condition is "as new" (based on furan levels) | 1    | LTC is operating satisfactorily. No special actions are recommended.   |
| Woodbourne T1 | 2011 | 10   | 1   | No abnormal gas generation is indicated. Fluid condition is within acceptable in-service parameters. Paper condition is "as new" (based on furan levels) | 1    | LTC is operating satisfactorily. No special actions are recommended.   |
| Woodbourne T2 | 1966 | 10   | 1   | No abnormal gas generation is indicated. Fluid condition is within acceptable in-service parameters. Paper condition is reduced to 80% tensile strength  | 2    | <b><i>Slightly abnormal dissipation of energy is noted. This is an early indication of fault or wear activity. Recommend retest within 150 days (5 months) for trending.</i></b> |

Table 17 - Summary of 2011 DGA Tests

Fault levels at the Zone substations are given below:

| Location      | 33KV 3Ø Fault Level (amps) | 33kV 1Ø Fault Level (amps) | 11kV 3Ø Fault Level (amps) | 11kV 1Ø Fault Level (amps) |
|---------------|----------------------------|----------------------------|----------------------------|----------------------------|
| Transpower    | 6,500                      | 1,500                      | n/a                        | n/a                        |
| Springlands   | 6,400                      | 1,500                      | 8,709                      | 10,237                     |
| Nelson Street | 5,601                      | 1,495                      | 8,176                      | 9,742                      |
| Redwoodtown   | 4,600                      | 1,413                      | 7,640                      | 2,958                      |
| Spring Creek  | 4,194                      | 1,363                      | 4,936                      | 2,673                      |
| Woodbourne    | 3,834                      | 1,302                      | 6,943                      | 8,345                      |
| Riverlands    | 2,829                      | 1,159                      | 4,992                      | 5,421                      |
| Renwick       | 2,690                      | 1,077                      | 5,030                      | 6,337                      |
| Picton        | 2,051                      | 808                        | 5,221                      | 2,235                      |
| Seddon        | 1,763                      | 832                        | 3,807                      | 4,985                      |
| Leefield      | 1,632                      | 1,114                      | 2,089                      | 2,476                      |
| Havelock      | 1,165                      | 577                        | 1,921                      | 2,382                      |
| Ward          | 979                        | 507                        | 1,648                      | 2,015                      |
| Linkwater     | 898                        | 467                        | 2,059                      | 2,753                      |
| Rai Valley    | 748                        | 404                        | 1,262                      | 1,537                      |

Table 18 - Fault Levels

All of the existing switchgear and equipment is suitable for the potential fault levels.

Graphs showing the zone substation loadings for the 2014 calendar year are included in appendix B.

## 2.6.7 Distribution Network

### 2.6.7.1 11kV Overhead Lines

The 11kV overhead lines are the most significant asset class both in terms of quantity and value. The RAB value of the 11kV and LV overhead is \$48 million, with an average age of 39.7 years, compared with an average expected life of 63.5 years.

The distribution Network is generally in a very tidy condition. Nearly half of the Network is constructed on concrete poles, and most of the balance on treated pine poles. Most conductors are aluminium, although some copper conductors remain in use on older lines. Additionally, some older spur lines have copper weld and galvanised steel conductors, typically located on short spur line sections of the Network where demand is relatively low and static. Replacement is subject to condition assessment

A programme is in place to identify those areas where changes in demand may require upgrades to the capacity of the Network, generally by way of increases in the conductor size.

The backbone of the Network system is constructed at three phase with some spur lines and lines at the extremities of the Network being single phase including 33 separate areas of single wire earth return. All of the distribution system currently operates at 11kV, New rural construction is generally at 22kV and, within the period of this plan, it is expected that some areas will be upgraded to 22kV.

Most of the Network uses flat construction hardwood cross-arms, although some limited areas have been altered to triangular construction in an endeavour to reduce faults from swan and duck strikes.

Most of the central area of the 11kV Network is capable of being ring-fed with supply available from at least two zone substations. This arrangement provides flexibility in the operation of the system, and enables supply to be maintained to most customers in this area at times of emergencies or planned outages. However a significant portion of MLL's Network is supplied by way of long radial spur lines, which have no alternative supply capabilities.

Most of the overhead reticulation has been constructed since 1960. Significant growth in the number of connections and in demand for electricity occurred in the 1960s and 1970s, and consequently considerable sections of the Network were upgraded at that time.

The age profile of the overhead distribution lines is shown on the following chart:

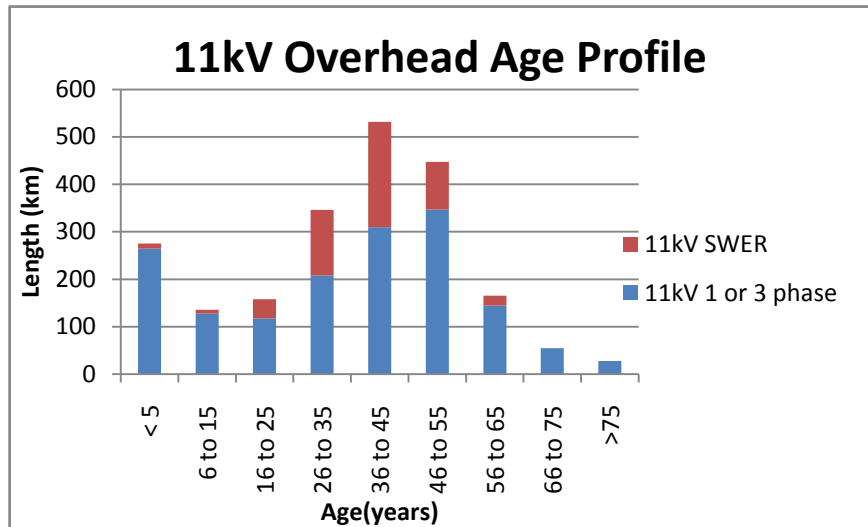

Figure 13 - 11kV Overhead Lines Age Profile

The above figure shows the age profile for 11kV overhead lines. Using useful lives of 45 years for wooden poles and 60 years for concrete and metal poles indicates that during the next 10 years, 1070 km of 11kV overhead lines will reach the end of their useful lives. In the following ten years a further 356 km will reach the end of their useful lives.

In Marlborough the environment is relatively benign and poles and lines do last longer than the useful lives given by the Information Disclosure requirements. Extending the useful lives by 10 years, i.e. using useful lives of 55 years for wooden pole lines and 70 years for concrete poled lines gives 303 km in the next ten years and a further 706 km in the following ten years.

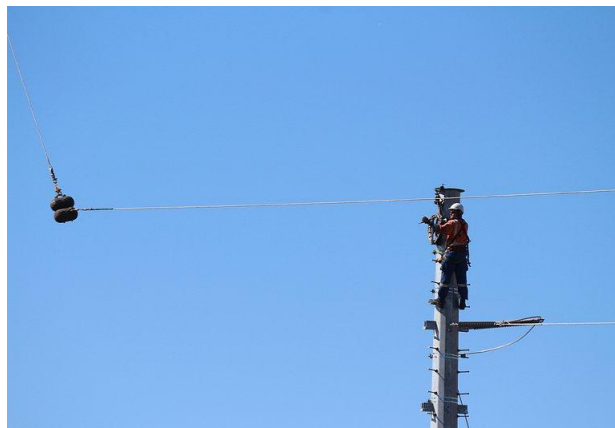

Photo 10 – Lineman placing rope from helicopter into pulley line roller.

Using the extend lives as the basis for renewal, MLL needs to replace 40-50km of the older lines each year. This will avoid lumps in expenditure and resource requirements. The targeting of the lines in poorest condition, and those requiring upgrade for capacity or to improve reliability, will ensure that renewal expenditure is allocated in ways that provides the most value to MLL and the community.

#### **2.6.7.2 11kV SWER Lines**

Single Wire Earth Return (SWER) lines have been used extensively throughout the more remote sections of MLL's Network, with a total of 550km of 11kV SWER lines currently in place. These lines can be constructed at significantly lower cost than the more traditional two and three wire systems, due to the ability to span longer distances without the possibility of mid-span wire clashing. This type of construction is ideally suited to areas of low population density, such as parts of the Marlborough Sounds and the upper Awatere Valley and especially where the terrain is undulating where pole numbers can be minimised.

The primary disadvantage of this type of construction is that it provides a single phase supply which can only deliver relatively low capacity. Stringent conditions related to earthing and interference with telecommunication systems apply to this type of construction.

The Electricity Engineers Association (EEA) has prepared a guide on HV SWER earthing. MLL has reviewed SWER earthing and considers that it is consistent with the EEA guide.

The voltage between the wires and ground for SWER is 1.73 times higher than for a three phase system. This increases the risk of fire and consequently special attention needs to be given to ensuring that vegetation is free of the lines.



**Photo 11 – SWER Lines in Tory Channel**

### 2.6.7.3 11kV Underground Cable

The 11kV underground reticulation is generally much newer than the overhead with an average age of 12 years and an average expected life of 47 years.

The age profile is shown on the following chart:

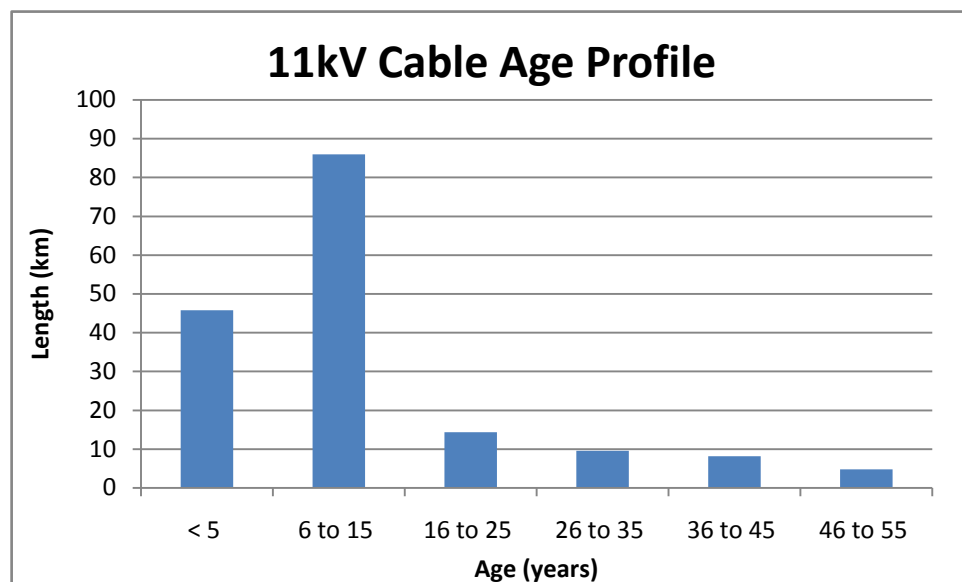

Figure 14 - 11kV Underground Cable Age Profile

The majority of these cables are XLPE (cross-linked polyethylene), the generally accepted useful life of which is 45 years, however there are reports of XLPE cables failing at 35 years. Based on 45 years for XLPE and 70 years for PILC, 5.5 km of cable will reach the end of its useful life within the next 10 years and a further 20km in the subsequent 10 years. Replacement of these cables will be costly, and accordingly it is planned to use partial discharge testing to monitor critical cables and prioritise their replacement.

The earthquakes in Christchurch have shown that cable networks are particularly vulnerable to ground movements. Where practical this will be taken into account in design and new alternate routes constructed.

### 2.6.8 Distribution Substations

Distribution transformers reduce the 11kV down to 415/240V. The majority of installations connected to the Network take supply at 415/240V. The distribution substations, transformers and associated equipment (e.g. fuses) have a total RAB value of \$23.7 million, with an average age of 27.2 years, compared to an estimated average useful life of 44 years. The age profile of MLL's 3798 distribution transformers is shown in the figure below:



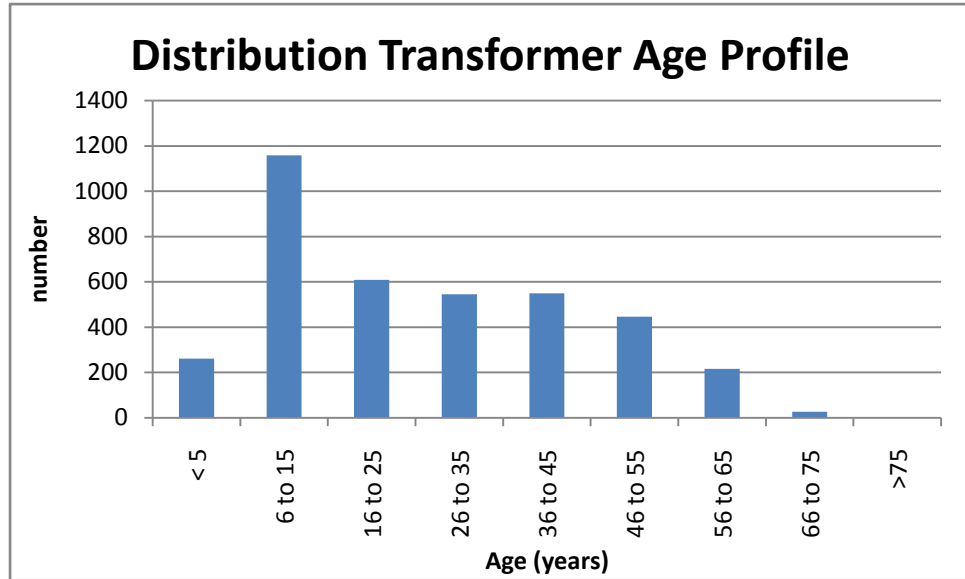

Figure 15 – Age Profile for Distribution Transformers

Using the Information Disclosure standard useful life of 45 years, there are currently 765 transformers due for replacement, with a further 540 due for replacement in the next 10 years. Using an extended life of 55 years, there are 253 due for replacement, with a further 512 due for replacement in the next 10 years. These numbers are consistent with current renewal rates.



Photo 12 -- Transformers in Taylor Pass Yard

The condition of the distribution transformers is generally good. Transformers greater than 200kVA have annual load monitoring/silica gel checks/physical inspections. Earthing is checked on an annual basis for substations in urban areas with high foot traffic or close to schools, three yearly for SWER substations and six yearly for all other substations. During the testing the transformer external condition is assessed. Aside from this inspection/maintenance transformers are generally run to failure unless potential problems are detected from network surveillance. Failure rates are monitored to look for any systemic problems with the transformer stock.

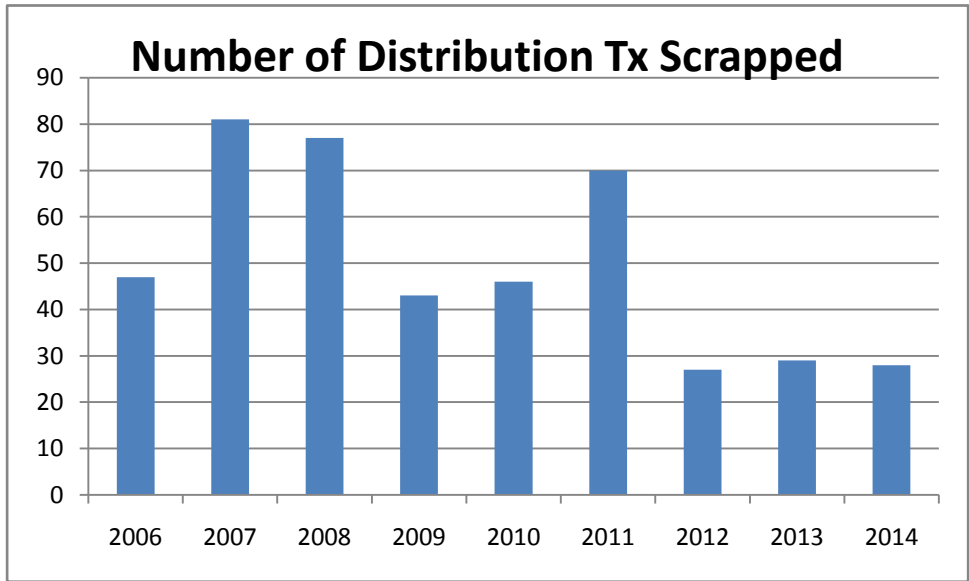

Figure 16 – Number of distribution transformers scrapped



Photo 13 - 11kV Transformer at Wind farm site

## 2.6.9 Distribution Switchgear

Distribution Switchgear covers a range of assets. The RAB value of these assets is \$16.6 million with an average age of 12 years compared to an average expected life of 37 years, i.e. it is generally relatively new. This category can be further split into the various assets classes:

### 2.6.9.1 Reclosers, Sectionalisers and Fusesavers

The use of pole mounted circuit breakers and sectionalisers along feeders helps to minimise the areas affected by faults and to decrease the time required for fault location and supply restoration. A breakdown of these devices is shown in the table below:

| Type           | Manufacturer          | Number | Notes                  |
|----------------|-----------------------|--------|------------------------|
| Reclosers      | Noja                  | 48     | SCADA capable          |
| Reclosers      | Nulec                 | 31     | SCADA capable          |
| Reclosers      | McGraw Edison/Coopers | 18     | Older need renewal     |
| Reclosers      | Reyrolle              | 2      | Older need renewal     |
| Sectionalisers | McGraw Edison/Coopers | 21     | Older need renewal     |
| Fusesavers     | Siemens               | 3      | Reduce fuse operations |

The older reclosers and sectionalisers have a mixture of mechanical and electric actuators. Historically these devices have often been unreliable, i.e. not operating for faults and occasionally operating when it seemed there were no faults present.

Replacement of these by the newer Noja and Nulec reclosers has a number of advantages:

- improvements in reliability
- ability to operate and monitor remotely using SCADA
- ability to use as part of smart grid, e.g. automatic reliving schemes
- ability to remotely change protection setting and schemes, e.g. reclose blocks.

Details of MLL plans for these devices over the next five years are shown in the following table:

| Type           | New Installations | Replace existing devices | Notes  |
|----------------|-------------------|--------------------------|--|
| Reclosers      | 10                | 20                       | Some older technology, some new devices to improve fault response. |
| Sectionalisers | 5                 | 21                       | Older technology   |
| Fusesavers     | 30                | 0                        | Reduce fuse operations and improve reliability                     |

### 2.6.9.2 Oil Switches, Ring Main Units

MLL has eleven 11 kV/400V indoor substations. Some of these substations use Oil Circuit Breakers (OCBs) complete with over-current and earth fault protection. Elsewhere oil switches have been used throughout the underground system as they provide flexibility for switching at a lower cost than circuit breakers.

### 2.6.9.3 Air Break Switches

Air Break Switches are used to provide sectionalising and to allow for changes in configuration within the overhead Network. They are also used to provide visible breaks and enhance safety when undertaking work on the lines.

Where appropriate and where practicable, live line techniques will be used to replace switches when circumstances dictate replacement.

### 2.6.9.4 Fault Locators

These devices are located along overhead feeders and give indication of any observed fault currents. This assists in the location of faults and speeds up the restoration of supply. Advances in this technology have been rapid and a number of fault location devices with attachments, which allow their use on poles with multiple circuits, have been installed. There are currently 144 fault locators installed throughout the Network. A number of fault indicators have been connected to the radio network and when operated by faults, now radio a message back to base for faster, more accurate response by fault staff.

## 2.6.10 Low Voltage Network

MLL has 737 km of LV reticulation, of which, 426km is overhead and 330km is underground. The overhead has a RAB value of \$4.3 million and an average age of 40 years compared to a useful life of 58.7 years, while the underground is newer and has a RAB value of \$10.1 million with an average age of 12.4 years compared to an estimated useful life of 45 years. The age profile for the 400V Network is shown in the table below:

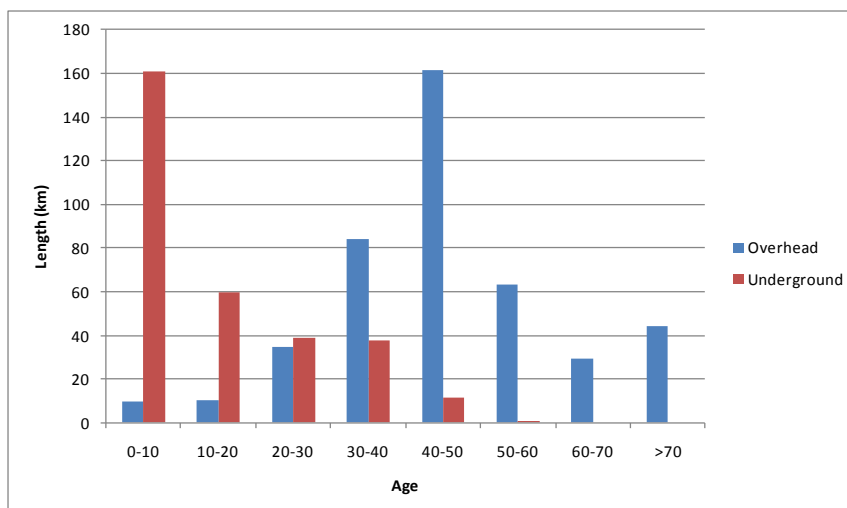

Figure 18 - LV Network Age Profile

One area of concern is the LV cables installed circa 1967 when the practice was to allow T-joints for ICP connections. This results in fault finding and isolation being difficult. Work is underway to install Distribution boxes every 3-4 houses to break the LV cable into manageable sections and remove Tee-Joints.

### 2.6.10.1 Distribution Boxes and Service Fuse Boxes

MLL has approximately 3200 LV distribution boxes and service fuse boxes. These are mainly associated with the LV network and are in good condition. Recent data capture projects have resulted in boxes being labelled and information in WASP/GIS being updated.

### 2.6.10.2 Fusing

Traditionally the overhead system used rewireable LV service fuses. These fuses have a very wide tolerance and tend to fail for mechanical as well as electrical reasons. All new fuses are now HRC to provide better protection and accuracy as well as better mechanical life. MLL is retrofitting HRC fuses when it undertakes work on the LV. The underground LV Network has always used HRC fuses.



Photo 14 - Work on Renewal of Lansdowne to Riverlands 33kV line

### 2.6.11 Ripple Injection

The existing load control system uses Zellweger decabit telegrams. They are injected into the system at 1050 Hz and 217Hz via 33kV coupling cells located in the switching structure alongside Springlands substation. Unfortunately the frequency of 1050 Hz gives rise to a number of problems. Due to the impedance and loading of the system (changed considerably since the plant was originally installed in the 1960s), signal amplification can occur in outlying areas. This can interfere with the operation of electronic equipment and manifest itself as noise in sound equipment, errors in clocks or malfunction of equipment such as microwaves, computers etc. The 217Hz frequency was introduced to overcome these problems. Once all new receivers are on the new frequency, it will be possible to phase out the 1050 Hz signal system.

In the past year, changes to the Transpower South Island configuration have resulted in overloading of the 1050 Hz injection plant on a number of occasions. Investigations by Enermet have shown that the coupling cells are badly overloaded and accordingly the level of output signal has been decreased. ongoing changes to the nature of the network (e.g. load growth and increasing use of electronics ) is likely to cause further decreases in impedance at 1050 Hz and subsequent reductions in the level of signal available. This indicates that the 1050 Hz relays may not be able to operate reliably within the short to medium term and should be phased out as soon as practical.

Compact Fluorescent Lamps (CFLs) produce harmonics. This is particularly the case for the lower cost lamps which have minimal in-built filtering. Testing and analysis has indicated that the harmonics produced are likely to interfere with the 1050 Hz ripple signal, thereby hastening its demise.

Note the 1050Hz and 217Hz relays are owned by the Energy Retailers and accordingly MLL has no control over when this signal can be phased out.

## 2.6.12 Automation and Communication Assets

### 2.6.12.1 SCADA System

Marlborough Lines operates an ODBC based SCADA system that is approximately 10 years old. It has undergone a recent upgrade with both new hardware and the latest version of software installed. The system has been designed to allow monitoring and remote control of devices in the Network, including circuit breakers, transformer tap changers, line reclosers, voltage regulators and the load management system.

The UHF radio network currently covers the Wairau, Kaituna, Awatere and Pelorus Valleys, as well as French Pass and the East Coast. Projects planned for 2015/16 will extend this coverage into Rai Valley, the Kenepuru Sound, Tory Channel, Port Underwood and the CBD. It is intended that by 2017, 88% of Marlborough Lines 11kV Network will have SCADA communications through the UHF network. As of 31 March 2015, approximately 80% of the 11kV Network has SCADA radio coverage. The remaining 20% of our network is generally in very remote areas therefore an increase in SCADA coverage now requires more sites with a smaller result each time. Having more repeater sites also helps to provide additional paths around site specific obstacles such as trees or buildings.

The UHF radios in use are capable of both serial and IP communication, future proofing the Network for developments in power system monitoring and control technology, and any other requirements the Company may have. The radios will not need replacement or upgrading within the planning horizon of this Asset Management Plan.

| Type             | Fibre Optic | Licensed Radio | Public Frequencies | Cellular | ADSL | Not Connected | Not SCADA Capable |
|------------------|-------------|----------------|--------------------|----------|------|---------------|-------------------|
| Zone Substations | 6           | 4              | 5                  |          | 1    |               |                   |
| Town Substations |             |                |                    |          |      | 2             | 4                 |
| 33kV Reclosers   |             | 8              | 3                  | 2        |      |               |                   |
| 11kV Reclosers   | 1           | 20             | 1                  | 7        | 2    | 3             | 8                 |
| SWER Reclosers   |             | 6              |                    | 2        |      | 6             | 9                 |
| 11kV Regulators  |             |                | 1                  | 8        |      |               | 5                 |

Table 19 – SCADA Connected Equipment/Communication Type

All zone substations have SCADA indication and control of their 11kV circuit breakers. Thirteen zone substations have SCADA indication and control of their 33kV circuit breakers.

Cost/benefit analysis is used to determine the priority sequence for SCADA connection of reclosers, and the upgrade of existing reclosers to new SCADA-capable models.

#### **2.6.12.2 Voice Communication Equipment**

Marlborough Lines owns and maintains its own UHF linked VHF radio voice communication system, which is used for switching and operational control of the Network. There are seven repeaters located on various hill tops throughout Marlborough. Each of these sites broadcasts in its local area using one of five VHF E band frequencies. To enable all radio users to hear all conversations and to allow the remote hilltop repeaters to be reached from areas outside the normal coverage area, all repeaters are linked together using a UHF link.

The total system involves:

- seven repeater sites
- vehicle mounted radios
- radios fixed in buildings/depots/offices/staff homes
- handheld mobile radios & backpack mobile radios

Due to the narrowband frequency deadline on 1 November 2015 MLL has upgraded all but two of our existing 25 kHz repeaters with new Tait 12.5 kHz models. The remaining repeaters will be upgraded in the next couple of months. We are on track to have all our analogue channels operating at 12.5 kHz by the end of September 2015.

MLL has also made a commitment to construct a new Digital Mobile Radio (DMR) Tier III voice network in addition to the analogue voice network. Digital radio has a number of advantages over analogue, in particular the ability to easily interpose data, alter the operation of the radio and add encryption. DMR can also be used to connect SCADA equipment to the system with a low bandwidth IP connection. MLL see this as a good option for remote devices where typical SCADA coverage does not reach.

By the end of 2015 we plan to have three DMR repeaters operating in the region, focusing on the central area first. All new vehicle radios are being installed DMR ready and several of the fault vehicles will be upgraded shortly. The staff that will gain the most from DMR will be the first to have access to it. Our radio status as at 31 March 2015:



| Radio          | Analogue Only | Digital Only | Digital & Analogue |
|----------------|---------------|--------------|--------------------|
| Repeater       | 7             |              |                    |
| Handheld Radio | 30            |              | 22                 |
| Vehicle Radio  | 55            |              | 32                 |
| Fixed Radio    | 27            |              |                    |

Table 21 – Voice communication equipment

### 2.6.12.3 Phone-in Devices

To assist in locating faults and to ensure prompt attention to any unusual events in the Network, around 60 ‘phone-in’ devices have been installed. These devices monitor the line voltage and report any brief interruptions (auto-reclosers), any permanent outages (faults or planned outages), and/or any out-of-limit voltages. They also phone in and advise when supply is restored to normal. The notifications are received by a PC which then advises appropriate staff of the event. This notification can be by email and/or cell phone text message. These devices have proved very useful in the early detection of abnormal conditions on the Network.

### 2.6.13 Metering

Metering in customer installations is owned by Energy Retailers. MLL only owns meters in zone substations and Network assets as part of the SCADA system.

### 2.6.14 Power Factor Correction

MLL currently has no power factor correction equipment, however the company is looking at installing some reactive support at Ward substation to compensate for the reactive loading imposed by the wind farms.

### 2.6.15 Mobile Substations/Generators

MLL has several generators used for operational support. The mobile fleet consists of:

- A 900kVA/11kV trailer mounted generator which is in the process of being upgraded to a 1.2 MVA unit.
- Two truck mounted generators, a 300kVA/11kV and 550kVA/11kV.
- One skid mounted 200kVA/415V.

MLL also has three fixed sites:

- A 550kVA generator at Elaine Bay
- Three 550kVA generators at Kenepuru Heads

- The 165kVA backup generator at the Taylor Pass depot has been converted to generate into the network.

The larger units are used to reduce outages when work is required on radial lines. The sites installed at Elaine Bay and Kenepuru Heads, i.e. past the commercial forestry located in these areas allow supply during logging and other forestry operations close to the 11kV distribution line.

These units are used to improve service during faults as well as reduce the effect of planned work. Generators allow the area affected by planned work to be reduced to the minimum area needed for the work. As much of MLL's rural network is radial, without generators it is necessary to shutdown everyone past the point of work, not just those in the immediate area of the work. As a secondary function, the generators are also utilised to reduce Marlborough's contribution to regional peaks in power consumption.

The earthquakes of recent years, as well as recent significant storms have reinforced the need for a Network company to have some mobile generation available for immediate use.

#### 2.6.16 Control Room

MLL has a control room for operation of the Network. This is staffed during normal business hours and after hours as required. Switching of the Network is controlled from the Control Room.

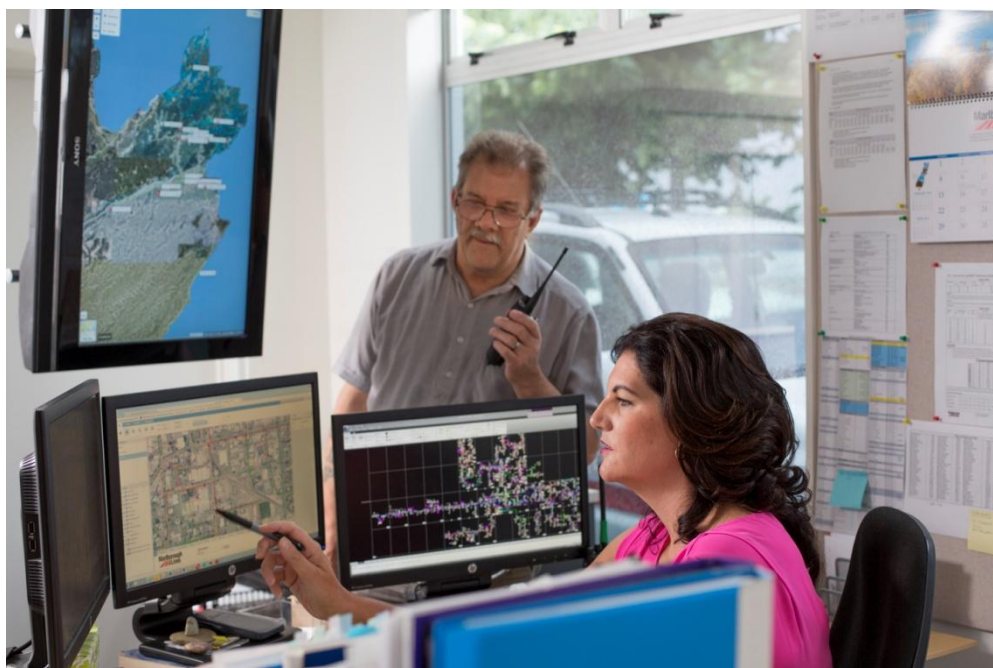

Photo 15 – New Control Room at Alfred Street

#### 2.6.17 Justification for Assets

Delivery of electricity to customers requires MLL to own and operate the classes of assets described in this section of the AMP. Electricity is an essential part of modern life and to a large extent is only noticed when it is not available.

Marlborough Lines Ltd is owned by its customers who require a level of supply and service which, in turn, requires the assets to be in place.

A further indicative measure is the degree of optimisation applied by the ODV valuation methodology, and accordingly the ratio of ODRC to DRC reinforced the need for the MLL asset justification. This ratio is typically in excess of 98.8%, meaning that very little optimisation is necessary and that the assets deployed are justified.

Justifications for key classes of assets are outlined in the table below:

| Asset Class                                   | Justification  |
|---|--|
| 33kV circuit-breakers within GXP              | Provide fault interruption and switching functionality at GXP end of 33kV lines.   |
| 33kV sub-transmission Network                 | Power transfer requirements beyond that of 11kV lines or cables.   |
| 33kV circuit-breakers within zone substations | Provide fault interruption and switching functionality at zone substation end of 33kV lines.   |
| 33/11kV transformers                          | Interface power transfer capability of 33kV Network with flexibility and safety of 11kV Network.   |
| 11kV distribution Network                     | Power transfer requirements beyond that of 400V lines or cables.   |
| 11kV SWER line                                | Low customer density does not justify more expensive configurations such as 2 or 3 phase. The single conductor configuration also eliminates conductor clashing enabling longer spans. |
| 11kV distribution switches                    | Provide additional fault interruption and switching functionality on 11kV Network.   |
| 11/0.4kV transformers                         | Interface power transfer capability of 11kV Network with flexibility and safety of 400V Network.   |
| 400V reticulation Network                     | Most cost effective way of delivering supply to low capacity customers.  |
| Load management equipment                     | Reduces load on Network and helps limit overall load on upper South Island, reducing Transpower charges.   |

**Table 20 - Justification for Asset Classes**

All current and projected levels of service can be justified by current ‘best power engineering’ practice.

### 3. Service Levels

MLL's Mission statement is "To exceed our customers' expectations in all aspects of our operations and furnish our shareholder with a commercial return".

The supply of electricity has become an essential part of modern life and customers expect the electricity supply to deliver sufficient power of a sufficient quality to enable them to undertake their activities with certainty and convenience, i.e. they expect the electricity supply to:

- be available;
- stay on with a minimum number of interruptions including momentary outages;
- have sufficient capacity available to ensure a suitable voltage level is maintained;
- be of a quality which allows equipment to function reliably (i.e. surges, sags, spikes and harmonics do not affect equipment);
- be provided at a reasonable cost.

#### 3.1 Defined Performance Indicators

The principal customer targets set for MLL are SAIDI, SAIFI and customer satisfaction. These are defined as:

**SAIDI** (System Average Interruption Duration Index): SAIDI is the average total duration of interruptions of supply that a customer experiences in the period. In essence, it is the average number of minutes that a customer has no supply for the year. SAIDI is calculated as:

$$SAIDI = \frac{\sum \text{No. of Interrupted Consumers} \times \text{Interruption Duration}}{\text{Total No. of Connected Consumers}}$$

*In minutes/connected consumer/year*

**SAIFI** (System Average Interruption Frequency Index): SAIFI is the average number of interruptions of supply that a customer experiences in the period. In essence it is the average number of times that supply goes off for each customer. SAIFI is calculated as:

$$SAIFI = \frac{\sum \text{No. of Interrupted Consumers}}{\text{Total No. of Connected Consumers}}$$

*In interruptions/connected consumer/year*

**Customer Satisfaction:** The percentage of random surveyed customers who are satisfied or very satisfied with Marlborough Lines' level of service.

The key service level targets are:

| Description                              | Target for YE 2015 | Target for YE 2016 | Target for YE 2017 | Target for YE 2018 to YE 2025 |
|--|--------------------|--------------------|--------------------|-------------------------------|
| Planned SAIDI (minutes/ICP/year)         | <80                | <75                | <70                | <70                           |
| Unplanned SAIDI (minutes/ICP/year)       | <115               | <110               | <105               | <100                          |
| Planned SAIFI (interruptions/ICP/year)   | <0.4               | <0.4               | <0.4               | <0.4                          |
| Unplanned SAIFI (interruptions/ICP/year) | <1.3               | <1.27              | <1.25              | <1.17                         |
| Customer Satisfaction                    | >90%               | >90%               | >90%               | >90%                          |

Table 21 - Key Service Level Targets

More details are contained in the Disclosure Information, which is included in appendix C.

These targets are lower than those used across previous years and reflect both our customer's expectations and the desire to lock-in the performance improvements achieved to date, as identified in the performance evaluation section of this plan. Further reductions in these reliability targets will be dependent on identifying improvement projects that meet economic tests against the community value of lost load or MLL have clear signals from the community identifying higher service level requirements.

## 3.2 Customer-oriented performance indicators

In addition to total network SAIDI and SAIFI, the fault response time is a further customer-orientated performance indicators to assist in monitoring performance from an end-user perspective.

### 3.2.1 Response times

The targets for fault response and power restoration are:

- Blenheim Urban 1.0 hours
- Urban Other 1.5 hours
- Rural 4.0 hours
- Remote Rural 8.0 hours

This will be monitored by recording the percentage of time this is achieved, i.e. the target in each case is 100%. These values represent stretch targets for MLL, particularly the urban response times as identified in the performance evaluation section of this plan.



Photo 16 – Trimming Vegetation near 11kV line

### 3.3 Detailed Service targets

Interruptions to supply can be of two main types: planned work where customers receive advance notice and can make alternative arrangements, and unplanned outages or faults. Since faults are more disruptive to customers, it is useful to break the SAIDI figures down into planned and unplanned outages.

Maintaining the supply of electricity throughout the Marlborough Sounds offers some unique challenges. In particular, low customer densities, long radial feeders, vegetation and difficult access (which dependant upon weather can be take many hours and/or require boat/helicopter). Urban areas have high concentrations of customers and meshed Networks and, accordingly, reliability should be higher in these areas than radial-fed areas such as the Sounds. In order to provide more useful information, SAIDI targets are split into Sounds, Rural and Urban areas. In practice, each feeder will be assigned one of these designations. Some feeders supply mixed areas e.g. the Waikawa feeder supplies part of Picton and an extensive area of the Sounds. These are classified as rural.

The detailed service levels for YE 2015 are:

| Description                      | Target for YE 2015<br>(minutes/ICP/year) on total MLL<br>basis |
|----------------------------------|--|
| <b>SAIDI for planned work</b>    | <80  |
| <b>SAIDI for faults – Total</b>  | <115   |
| <b>SAIDI for faults – Urban</b>  | <14  |
| <b>SAIDI for faults – Rural</b>  | <61  |
| <b>SAIDI for faults - Sounds</b> | <25  |

Table 22 - Detailed Service Level Targets

The targets for unplanned outages in the table above are set, based upon the unplanned SAIDI trend across the last 5 years and MLL’s effort to reduce unplanned outages within the network as far as practicable. Given that faults are highly variable depending on the weather events during the year, they are based on the expectation of an ‘average’ weather year.

The final group of detailed service level targets relate to the number of interruptions per area.

| Description                                 | Target for YE 2015<br>Total Number of interruptions | Target for YE 2016 to 2025 Total<br>Number of interruptions |
|---|---|---|
| Number of Interruptions for Planned Work    | <250  | <250  |
| Number of fault interruptions – Urban Area  | <25   | <25   |
| Number of fault interruptions – Rural Area  | <240  | <240  |
| Number of fault interruptions – Sounds Area | <55   | <55   |

Table 23 - Targets for maximum number of interruptions

Again, the above targets represent a locking-in of the modest performance improvement trend over the last 5 years as identified in the performance evaluation section of this plan.

The targets summarised in the table above are indicative of MLL’s commitment improve performance. This commitment has resulted in continual improvement over the past 5 years and is identified in the performance evaluation section of this plan.



Photo 17 – Typical Marlborough Sounds setting

### 3.4 Asset Performance Indicators

The Asset Performance and Efficiency targets adopted by MLL are:

- **Load factor (ratio of average demand to maximum demand).**

This is influenced by the manner in which load control, primarily hot water cylinders, is used and to a lesser extent peak load generation. Currently, Transpower charges are based on the maximum demand on the Blenheim GXP at the time of maximum total demand of the upper South Island. This means that at other times, there is no financial incentive to cut hot water supply to houses. The result of this is to not limit maximum demand through load shedding, in turn reducing load factor, during high load periods within Marlborough that are not coincident with upper South Island maximum demand. This provides benefit to the customer as service is improved. Over the last 5 years, network load factor has averaged approximately 61% against a target load factor of 65%. In this plan the target of 65% is retained but may be reviewed in future plans.

- **System losses (ratio of energy lost to total energy entering the system).**

The volume of electricity sold, from which the volume lost is derived, is based on data provided by the electricity retailers trading on MLL's system. Because MLL has no control over the reliability of this data, the calculated volume of energy lost in any year may not be accurate. It is also salient not all meters are read simultaneously. In general terms, the losses derived for the MLL Network are consistent with those expected for a Network of this kind i.e. a predominantly radial network supplied from a single point of supply and with fewer customers per transformer than in a purely urban area. Work is being undertaken to improve the reliability and accuracy of this data. As shown in the performance evaluation section, MLL plot just below the regression line expectation on this measure with relatively consistent performance at approximately 5%. In this plan the target of 7% is retained but may be reviewed in future plans.

- **Capacity utilisation (ratio of maximum demand to installed transformer capacity).**

MLL's Capacity of Utilisation (CoU) has declined and is expected to decline further in the coming years, as the classes of seasonal load that utilise capacity for a relatively brief period increase. For example, baches in the Sounds, wineries and irrigation all require transformer capacity, but these loads make little or no contribution to maximum demand set during winter months, thereby reducing capacity utilisation. As shown in the performance evaluation section of this plan, the capacity of utilisation plots close to the expectation line in comparison to other distribution companies, particularly after adjustment for non-standard loads. The current target of 21% is therefore retained in this plan.



MLL's targets for these measures are summarised in Table 24 below:

| Measure              | Target (for entire planning period) |
|----------------------|-------------------------------------|
| Load factor          | 65%                                 |
| System losses        | 7%                                  |
| Capacity utilisation | 21%                                 |

Table 24 - Summary of Efficiency Measures

### 3.4.1 Justification for Targets

The Network performance and efficiency targets are based largely on historical and comparative performance and are likely to only change slowly.

Load factor, system losses and the capacity of utilisation are of less interest to customers than reliability. To a large extent, the performance measures are a direct consequence of customer requirements, design standards and previous decisions on system configuration and network expenditure.

MLL considers these factors in its decisions on network expenditure and how this provides benefits for stakeholders.

### 3.5 Basis of performance indicators

The reasons MLL targets 160 SAIDI minutes instead of some other lesser (or greater) figure are broadly as follows:

- The Network has an inherent reliability that has been shaped by policies and standards dating back many years that impose long-term implications. To make significant changes to reliability, substantial changes in expenditure would be required. Significant increases in expenditure cannot be contemplated given that many lines are presently uneconomic. Irrespective of this, MLL is constantly reviewing its practices and the advance of technology with the objective of maximising reliability of supply where it is economically feasible to do so. In essence, a long radial line for which there is no alternative supply must inherently be subject to outages. A secondary effect of this type of Network is that SAIDI figures can vary significantly from year to year depending on weather events in that year and the location of faults e.g. a fault near the beginning of a radial feeder results in all connected customers on that feeder to lose power.
- A rule of diminishing returns applies whereby each additional dollar of expenditure on reliability delivers a diminishing improvement. Accordingly, it is necessary to balance the expenditure on reliability with customer expectations of service and cost, together with network requirements such as minimising fire risk. Customer surveys continue to indicate a very high level of satisfaction with MLL's performance and it is considered that the current balance is acceptable. Comparative assessment to other businesses also indicates that MLL is at a balance point between the reliability delivered and the service cost of achieving that.

- Customer surveys indicate that customers generally want to retain or improve the current levels of reliability. There is no desire on the part of customers to see reliability reduced.
- Expenditure on the Network assists in achieving long term reliability; however, in the short term it can reduce total reliability as shutdowns are sometimes required to undertake the work.

Overall, MLL justifies its target SAIDI on customers' expectations of service and what is reasonable with the current funding and the asset characteristics of the Network.

These targets have been developed around the concept of continuous improvement whilst recognising that in the more remote areas it is not realistic to expect large improvements to reliability without significant expenditure, which is unlikely to be justified on a cost/benefit basis. Typically this is recognised by customers in remote areas. Customer surveys and feedback suggest that reliability of supply is important to all customers.

### **3.5.1 Changes to Performance Indicators**

Changes and improvements to the set of performance indicators will mainly be from improvements to data collection and changes to the IT systems which hold the performance data and calculate the performance indicators. Additional performance measures may be introduced which would assist MLL in measuring and managing change initiatives that may arise.

## 4. Network development planning

Marlborough Lines Ltd undertakes expenditure in a timely manner to ensure that appropriate levels of Network service and reliability are provided in accordance with customer expectations.



Photo 18 – Springlands substation, Blenheim

### 4.1 Planning criteria and assumptions

MLL has adopted a range of planning processes and technical and engineering standards to ensure that the assets required to deliver service levels meet the following requirements, that is to:

- Prevent unnecessary investment.
- Minimise risk of long-term stranding.
- Comply with regulatory requirements.
- Maximise operational flexibility.
- Maximise the fit with organisational capabilities such as engineering and operational expertise and vendor support.
- Comply with environmental and public safety requirements.
- Be appropriate to environment, e.g. service in the Sounds fits within the context of low customer density.

For example, the key criteria considered for 11kV/415V transformers is the maximum demand and delivery of required voltage. Transformers of 200kVA, or greater, are monitored and any transformer where the indicated load exceeds the transformer rating is considered for upgrade. Other options such as rebalancing, and or moving load to other transformers are also considered. Other factors taken into account are the load duration, i.e. how often the transformer is close to, or above its ratings, and the time of day and year of the highest loadings.

Increases in load are then reflected upstream through the various classes of MLL assets back to the Transpower GXP. The load on all 11kV feeders, zone substations and the 33kV feeders is continuously monitored and the data is used for system modelling and project planning purposes. The planning criteria (“trigger points”) for each asset class are described below.

## 4.2 Trigger Points for Planning Purposes

MLL has a broad range of criteria that represent trigger points for triggering remedial action across its varying classes of fixed assets. These are summarised in Table 25.

| Asset Class                      | Capacity Criteria  | Reliability Criteria   | Security of Supply Criteria   | Voltage Criteria  |
|----------------------------------|--|--|---|---|
| 400V reticulation network        | Conductor or fuse rating   | Blenheim CBD – 50% of load restored within 0.5 hours of fault, 100% within 1 hour<br>Elsewhere – restored within repair time | (n) security of supply for standard residential or commercial connection  | Voltage falls below 0.94pu at customer's point of supply based on 1 <sup>st</sup> percentile and 99 percentile. |
| 11/0.4kV distribution substation | Transformer rating (kVA)   | Blenheim CBD – 50% of load restored within 0.5 hours of fault, 100% within 1 hour<br>Elsewhere – restored within repair time | (n-1) security for most urban distribution subs<br><br>N security for most rural subs, with rapid transformer replacement, or use of mobile generator |   |
| 11kV distribution network        | Current exceeds 90% of thermal rating for more than 15 hours per year                  | Meshed Feeder - 50% of load restored within 0.5 hours of fault, 100% within 1 hour<br>Radial Feeder – repair time            | (n-1) security for most of the urban 11kV network<br>(n) security for rural 11kV Network  | Voltage falls below 0.95 pu for more than 100 hours per annum   |
| 11kV distribution hardware       | As appropriate to equipment. Not to exceed maximum rating                              |  |   |   |
| 33/11kV zone substation          | Firm capacity available 98% of the time, i.e. can exceed firm capacity for 2% of time. | 50% of load restored within 2 hours of fault   | (n-1) > 5MVA<br>(n) < 5MVA  | Able to cope with 0.85pu to 1.05 pu on 33kV Network and provide 11.2kV on bus.                                  |
| 33kV sub-transmission network    | Current exceeds 66% of thermal rating for more than 1500 hours per year                |  | (n-1) > 5MVA<br>(n) < 5MVA  | >0.85pu at all zone substations connections with 1.0pu at GXP.  |

Table 25 - Summary of Planning Trigger Points

### 4.3 Strategies for standardising assets and designs

The Network Standards document the design and construction of Network assets. The Network Standards are used for all assets where ownership and/or maintenance responsibility will ultimately rest with MLL.

The Standards contain information and drawings to be used in designing Network assets and detail the procedures for design approval and construction. These standards and policies help to ensure that public safety is considered at the design phase and assist MLL in meeting its obligations under the Electricity (Safety) Regulations 2010. They also assist in providing assets of appropriate quality to ensure that the reliability of supply is maintained or improved, consistent with the requirements of the Commerce Commission.

Marlborough Lines Ltd, along with a number of EDBs within New Zealand has access to, and the use of, the Powerco Contract Works and Network Operations guide. Where it is suitable, material from these standards is used to develop MLL's own standards. This also increases the standardisation across the industry.

MLL is also part of a multi-company buying group for cable, line hardware and store items. This has led to cross-company standardisation and reduction in the number of store items, unit costs and inventory held.

Recently MLL has become a member of the Collective Network Operations Group which includes all south island lines companies. The purpose of the group is to work towards common access processes, documentation, competency training and assessment, consistent operational requirements and emergency plans.

### 4.4 Strategies for energy efficiency

MLL monitors losses and consider losses when looking at system configuration and Network development. In practice, the physical considerations (e.g. conductor size and pole spacing) and the requirement to deliver regulatory voltage tend to take priority at the asset design and construction phases of the lifecycle and this determines the losses.

Energy efficiency initiatives should also include electricity users. MLL has interposed Use of System Agreements (UoSA) with Energy Retailers. This means that MLL does not have direct access to customers and therefore has less ability to influence end-user behaviour than energy retailers.

MLL considers energy efficiency when purchasing and replacing transformers. Lines pricing is designed to incentivise customers to install transformers of an appropriate rating, however in many cases, customers and their consultants prefer to over specify transformer capacity.

### 4.5 Determining capacity

The theoretical starting point for quantifying new capacity is to build "just enough, just in time", and then add a bit more over time. However MLL recognises the following practical issues:

- The standard size of many components, which makes investment lumpy.

- In terms of some items such as power transformers and underground cables, the marginal cost of providing additional capacity for the future is typically relatively small.
- The current regulatory constraints on investment, and the ability of MLL to obtain a commercial return on investment.
- The one-off costs of construction, consenting, traffic management, access to land and reinstatement of sealed surfaces, which may make it preferable to install additional capacity rather than have to return in the short to medium future. This is especially the case when it is considered that Network assets typically have long lives, far in excess of the regulatory period and the 10 year horizon of this Plan.
- The addition of extra capacity can, in some cases, require complete reconstruction, for example where larger conductor requires stronger poles or closer pole spacings, leading to considerable increases in total cost of ownership if an incremental approach is used at the outset.
- The need to avoid over-load risk. Over-load can lead to asset failure, reductions in service and reductions in asset lives.

MLL's guiding principle is therefore to minimise the level of investment ahead of demand while minimising the costs associated with doing the work. In recognition that typically the costs of investment in advance of requirements is far better than investment after failure has occurred or customer supply lost.

#### 4.6 Prioritising Network development projects

In prioritising development work, MLL looks at the estimated cost and the benefits that the expenditure will bring. Consideration is given to why the work is required and accordingly, the benefits which undertaking it would provide. Work with the greatest cost/benefit ratio is undertaken first. In assessing the benefits the various reasons are given a weighting as per the table below:

| Description       | Comments  | Rating (10=highest) |
|-------------------|---|---------------------|
| Safety            | MLL will not compromise the safety of staff, contractors and the public. Safety is fundamental to the way MLL undertakes any activity and accordingly it has top priority on all expenditure. | 10                  |
| Capacity          | Overloading can lead to overheating, reduction in asset life, fire, explosion and cascade tripping (security of supply is implicit within this).  | 9                   |
| Reliability       | Customers want a reliable supply.   | 8                   |
| Voltage           | Customers want equipment to operate well and this requires stable and appropriate voltage levels to be maintained.  | 7                   |
| Environmental     | Minimising the impact on the environment is a key part of MLL's values, especially in highly sensitive areas.   | 5                   |
| Energy Efficiency | Primarily energy efficiency within the network is largely dependent on the network's configuration. The provision of supply at regulatory voltage and at                                      |                     |

| Description                  | Comments  | Rating<br>(10=highest) |
|------------------------------|---|------------------------|
|                              | a cost acceptable to customers means that energy efficiency cannot be the primary determinant of expenditure. Inherent in a low customer density network are an increased number of transformers, all of which incur losses regardless of consumption. Energy efficiency is taken into account during design and purchase of network components such as transformers.<br>MLL also seeks to maximise the efficiency of its network through operations, notwithstanding the limitations imposed by the physical constraints of the network. |                        |
| Renewal (end of useful life) | Lower priority assuming that it is safe, has adequate capacity, good voltage and low maintenance costs.   | 6                      |

Table 26 – Development Work Prioritisation Criteria

In assessing the potential benefits of the work, consideration is also given to the number of affected customers, the total kW/kWh and the impact (if any) on revenue/ costs, e.g. reductions in maintenance/ increased line charges.

Potential projects come from a wide range of work including technical studies of the Network, e.g. load flow analysis, customer requests, consideration of load growth, information on proposed load changes, examination of existing constraints and limitations within the Network and asset monitoring e.g. large concentrations of maintenance work may result in line renewal and fault studies.

Projects are developed and budget pricing is undertaken. The benefits are assessed in terms of the criteria above and projects ranked. This is undertaken by the Engineering Manager in conjunction with engineering staff. From this information a draft plan and budget is developed. This is then discussed with, and approved, by the Managing Director before being submitted to the Board for approval or alteration. Once approved, it is included within MLL's annual budget.

#### 4.7 Demand forecasts

The following base assumptions are used for demand forecasts:

- The resident population will continue to grow at about the average rate of the last five years.
- Existing major loads will remain for the entire planning horizon.
- The Riverlands industrial estate will continue to grow at approximately the current rate for the entire planning horizon.
- Vineyard conversions of land will gradually increase.
- The mussel and salmon industries will continue to grow at the average rate of the last five years for the planning horizon.

- The current level of forest harvest will continue.
- The ferry terminal will remain in Picton.
- Load control measures will continue to be used at the same level.
- Sufficient generation will be available to supply all load, and Transpower will provide and maintain the assets required to deliver supply to MLL.
- If further embedded wind generation proceeds it will not be sufficiently diverse or reliable to allow reductions in investment in the Network or reduce the demand forecast. It is possible this may be a driver for more investment as generation companies require additional capacity for the connection of generation.
- Solar (PV) installations will continue to increase over the next five years with a range of smaller units (0-5kW) installed in residential situations and larger units (25-100kW) at commercial and industrial locations, however the total will still be very small compared to wind and hydro (15GWh per annum). Unless these installations have appropriate storage, backup separate from MLL's network will typically be required.
- Demand-side management is assumed to have no real effect on load growth and Network capacity requirements. Until prices increase substantially, it is considered that load management will have little effect on load growth, which is mainly driven by economic factors.
- We are starting to see an increase in demand as the economy exits the recession seen in previous year's load growth. This increase needs to be monitored closely.

Consideration is also given to the general and regional economic outlook. Resource consent applications to Marlborough District Council are evaluated and recorded. These indicate the level of development in various areas for either subdivisions or specific land use such as irrigation. To date there has been good correlation between consents and short to medium term load growth.



Photo 19 - Vineyards



Nevertheless, forecasting of future demands has a very high degree of uncertainty. Actual demands are the result of the complex interaction of a series of factors, some of which are impossible to predict. Primarily, demand and consumption is related to weather. A cold winter with increased levels of heating or a dry early summer with significant utilisation of irrigation are major factors which significantly alter demand and usage on a year to year basis.

The graph below shows the load duration curve on Transpower’s Blenheim GXP for the calendar years 2009 and 2014.

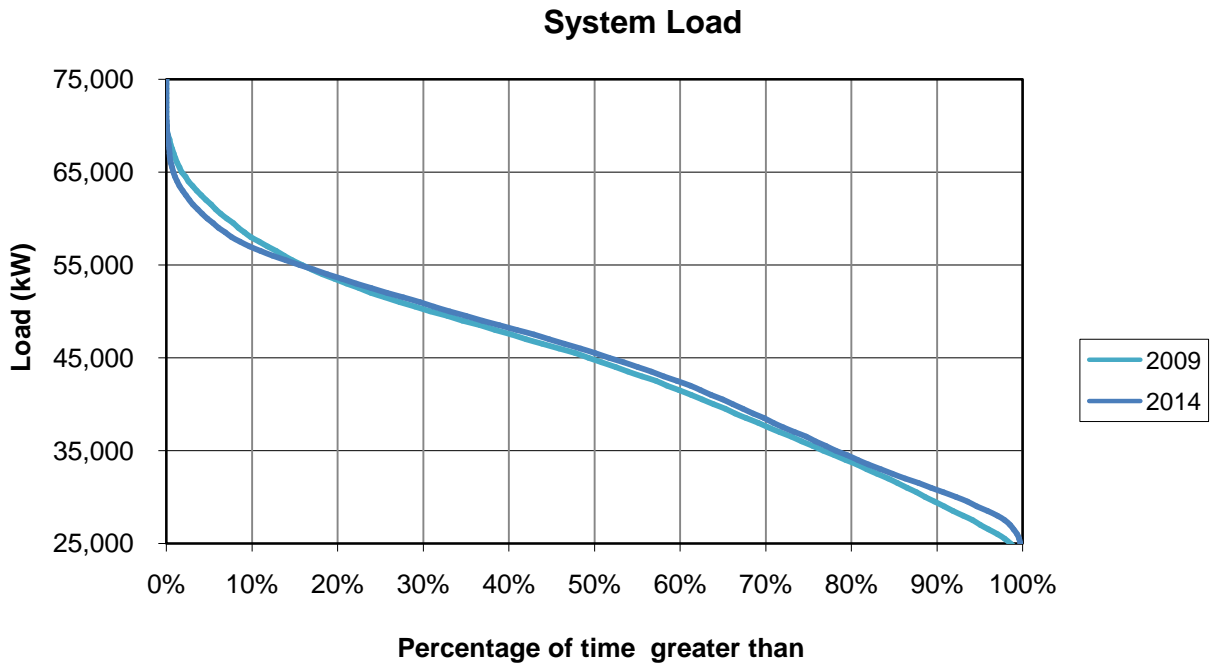

Figure 19 – Blenheim Load Duration

This graph shows the difference in load from 2009 to 2014. Since 2009 the maximum demand and energy has essentially been static, despite additional customers and transformers being connected. This is due in part to greater uptake of more energy efficient loads, such as compact fluorescent lamps and higher efficiency motors and partly a response to the GFC.

The Table below shows historical growth rates and the rate used for planning purposes.

| Description          | Growth over last year | Annual Growth Over Last 5 Years | Annual Growth Over Last 10 Years | Rate Used for Planning Purposes |
|----------------------|-----------------------|---------------------------------|----------------------------------|---------------------------------|
| Maximum Demand       | 1.8%                  | 0.1%                            | 2.6%                             | 1.5%                            |
| Energy               | 2.1%                  | 0.2%                            | 1.5%                             | 1.5%                            |
| Transformer capacity | 2.6%                  | 2%                              | 3.6%                             | 1.5%                            |

Table 27 - Overall Growth Rates

Note that the rate used for planning is less than the average over the last 10 years, but still greater than the last 5 years because of the recent recession. Growth over the last year has increased greatly almost back to where it was before the recession. The planning rate will be left at 1.5% in the interim until a more stable current growth rate is known. In the event that the actual rate is greater than this, the effect will be to bring forward work, i.e. it will generally only affect the timing of projects. MLL's historical demand and projected demand are shown in Figure 21, while Table 28 disaggregates the projected growth over the 16 zone substations.

The overall risk associated with Network investment is asymmetrical. It is better to have invested prior to the need for increased capacity than after customer supply or service has been restricted, i.e. to wait until the demand exists, is too late.

Further factors which may influence actual growth are:

- Energy demand associated with discretionary products such as salmon and wine may decline and impact on Marlborough as a result of the current economic conditions.
- The number of new connections may decline and/or existing installations disconnect as a result of the current economic conditions or utilisation of off grid systems.
- Middle East tensions and varying fuel supplies are causing fluctuations in the price of petrol and diesel, which has a direct impact on the economy. Large increases in oil price may lead to further work and uptake of electric vehicles. However it is considered unlikely that electric vehicle use will increase markedly within the next five years, but should such occur MLL does not expect to incur any difficulty in meeting demand. Likewise a decrease in oil price may defer investment/demand for electricity.

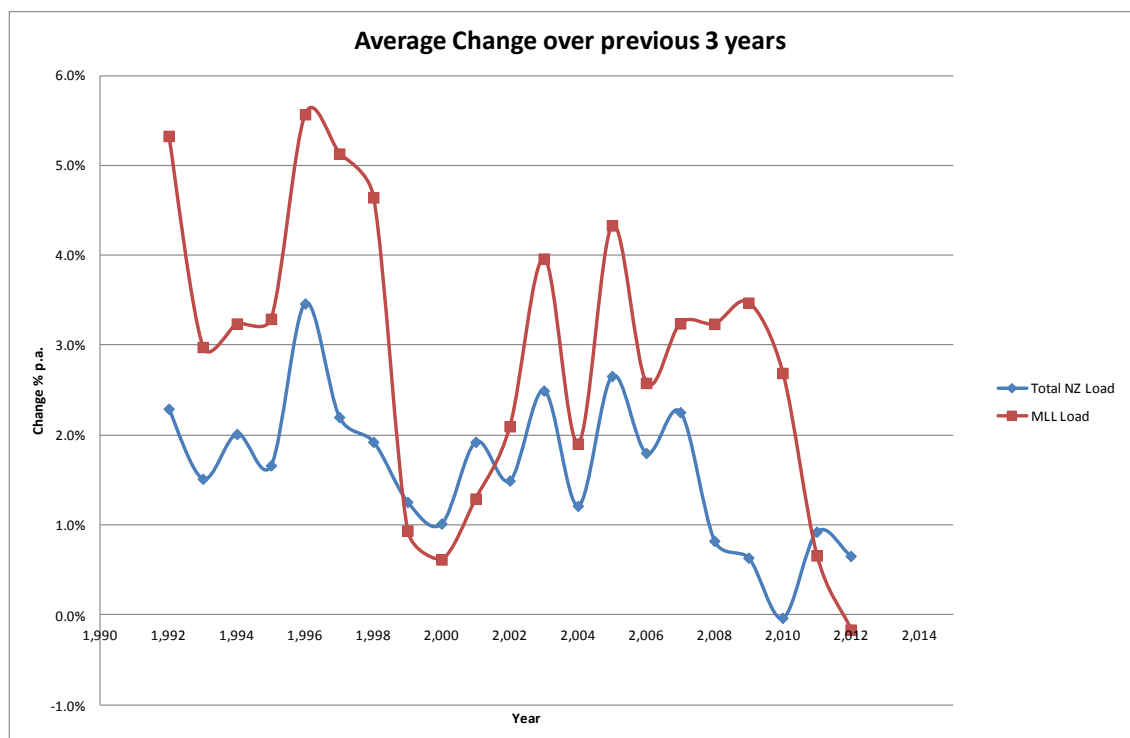

Figure 20 - Average growth rates for NZ and MLL load

Figure 20 shows the average change in the total NZ load and the Marlborough Load. This shows that the MLL load is affected by many of the same factors as the national load, in particular the national/international economy and the weather. But because of Marlborough’s dependence on primary products, its economy can be disproportionate relative to areas such as Auckland, Wellington and Christchurch.

Figure 21 shows the expected load and energy growth for the period of this AMP and relies on MED data of which the most recent is 2012.

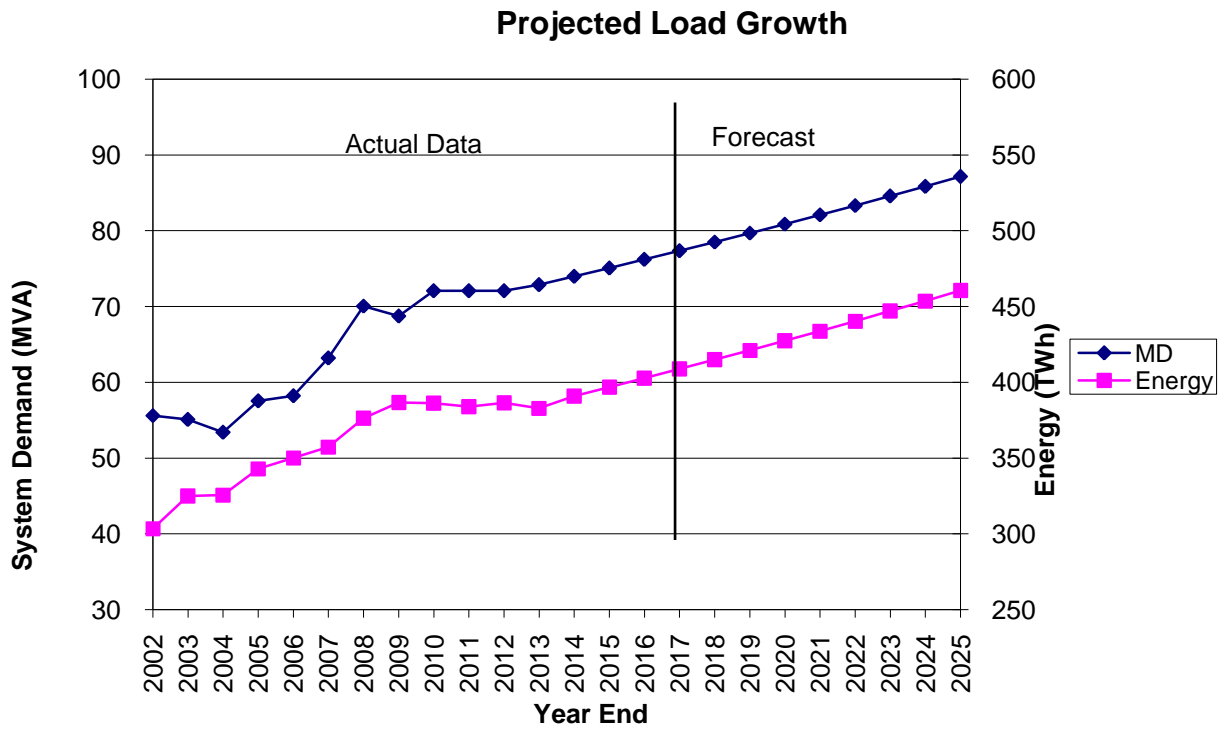

Figure 21 - Projected Load Growth

## 4.8 Zone Substation Demand Forecasts

The table on the following page shows the capacity of the 33kV/11kV zone substations and the effect of load growth on them. This information is also shown in Schedule S12c which is included in appendix B.

| Substation   | T1             | T2             | Maximum Demand | Estimated Demand (MVA) | Notes   |
|--------------|----------------|----------------|----------------|------------------------|---|
|              | Capacity (MVA) | Capacity (MVA) | 2014           | 2019                   |   |
| Cloudy Bay   | 16.5           | 16.5           | 4.2            | 9                      | Some load to be moved from Riverlands.  |
| Leefield     | 5              |                | 1.1            | 1.3                    |   |
| Linkwater    | 5              | 5              | 3.7            | 4.1                    | Maximum loading is for holiday periods only   |
| Havelock     | 5              | 5              | 4.0            | 4.4                    |   |
| Nelson St    | 16.5           | 16.5           | 14.6           | 14.7                   |   |
| Picton       | 16.5           | 16.5           | 6.7            | 6.7                    |   |
| Rai Valley   | 3              | 5              | 1.9            | 1.9                    | (n-1) of 3MVA. New TX installed 2014  |
| Redwoodtown  | 16.5           | 16.5           | 10.3           | 10.3                   |   |
| Renwick      | 10             | 10             | 9.5            | 10.4                   | May be reduced by moving open points, eventually new zone substation capacity required. |
| Riverlands   | 10             | 10             | 9.6            | 11.2                   | Approaching n-1 capacity - some load may be able to be moved to Cloudy Bay              |
| Seddon       | 10             | 10             | 5.3            | 7.2                    |   |
| Spring Creek | 5              | 5              | 4.0            | 4.4                    |   |
| Springlands  | 16.5           | 16.5           | 10.4           | 10.4                   |   |
| Ward         | 2              | 2              | 1.7            | 2.4                    | Transformers are 56 years old and if load grows may need to be renewed.                 |
| Waters       | 16.5           | 16.5           | 6.8            | 6.8                    |   |
| Woodbourne   | 10             | 10             | 7.7            | 8.4                    | Can be reduced by moving open points  |

Table 28 - Zone Substation Loadings and Growth

For planning purposes the growth figures used take into account the factors identified in section 4.7, while looking at changes in load, installed transformer capacity and projected demand, together with the type of loads and the local economy, as a basis for assessing future load growth.

All of MLL's substations other than Leefield have (n-1) security for the 33/11kV transformers, e.g. for a substation to have a firm (n-1) 16.5MVA rating it must have two transformers of 16.5MVA. Note Linkwater, Rai Valley, Leefield and Ward substations only have a single 33kV line supplying them, and consequently have an overall security of supply of (n).

A key implication of increasing demand is that the percentage of time for which a stated level of security is available will decline (assessed from load duration curves). When this percentage declines to a level that is considered unacceptable, security reinforcement will occur. What is regarded as unacceptable will depend on the precise circumstances, in particular customer requirements and the proximity of other assets from which additional security can be obtained.

From the table above Renwick and Riverlands will be loaded beyond their (n-1) level by 2019. Using the current growth rate of load at Renwick and allowing the (n-1) rating to be exceeded 5% of the time, then additional capacity is required to be commissioned in five to 10 years time.

Load can be transferred from Riverlands Sub to Cloudy Bay Sub by the installation of a new feeder tie cable into the Liverpool street area. This will defer the need to install more capacity at Riverlands during this AMP period.

Ward substation has 1790 kVA of wind driven induction generators connected, i.e. more than the connected load and close to the n-1 capacity of the substation. MLL does not consider it necessary to maintain (n-1) security for distributed generation unless negotiated by the owner of the wind generator.

MLL currently has land available for future construction of Zone Substations at Hammerichs Road, Waihopai River/SH63, Marlborough Ridge Development and Budge Street.

#### **4.9 Significant development options available**

A range of options are available when trigger points are exceeded:

- 'Do nothing', and simply accept that one or more criteria has exceeded a trigger point. In reality, 'do nothing' options would only be adopted if the benefit/cost ratio of all reasonable options were unacceptably low and if it was considered that the 'do nothing' option did not represent an unacceptable increase in either safety, commercial or regulatory risk to MLL. The low customer density and low kWh consumption in many parts of the Sounds typify such occurrences of low benefit/cost ratios. The cost benefit ratio involved in correcting minor mismatches (e.g. low voltage for a few hours per annum) are simply too low.
- Construct new distribution assets that will move (generally increase) an asset's trigger point to a level at which it is not exceeded. An example would be to construct an additional new 300kVA distribution transformer/substation to reduce loading on an existing 300kVA transformer.

- Modify distribution assets so that the asset’s trigger point will move to a level that is not exceeded. This is essentially a subset of the above approach, but will generally involve less expenditure. An example would be installing additional cooling on a 33/11kV transformer to allow a greater maximum demand at a lower cost than installing a bigger transformer that might be under-utilised a lot of the time.
- Retrofitting high-technology devices that can exploit the features of existing assets through careful monitoring which moves the asset’s trigger point. Examples might be SCADA monitoring of transformer core temperatures to enable higher cyclic loadings instead of installing a higher rated transformer, or using remotely switched air-breaks to improve reliability.
- Operational activities that alter the asset’s activity level relative to the trigger point, in particular switching on the 11kV to shift load from heavily-loaded to lightly-loaded zone substations to avoid new investment. The downside to this approach is that it may increase line losses, reduce security of supply, or compromise protection settings.
- Construct distributed generation so that the performance of neighbouring distribution assets is restored to a level below their trigger points. Distributed generation would be particularly useful where energy is currently going to waste e.g. steam from a process. It should be noted that distributed generation such as wind or solar is unlikely to reduce capacity required on the Network, as it lacks sufficient diversity/storage in this context i.e. on a still, cold winter’s night, the effect of wind/solar on the Network assets’ capacity is likely to be insignificant. The most likely application for distributed generation in MLL’s context is diesel generators in the Sounds.
- Influence customers to alter their consumption patterns so that assets perform at levels below the trigger points. Examples might be to shift demand to different time zones, negotiate interruptible tariffs with certain customers so that overloaded assets can be relieved, or assist a customer to adopt a substitute energy source to avoid new capacity. It is noted that the required separation of lines and energy functions makes demand management very difficult, if not impossible.

Table 29 summarises these approaches.

| Approach                       | Effect on Asset’s Activity Level             | Effect on Asset’s Trigger Point |
|--------------------------------|--|---------------------------------|
| Do-nothing                     | Activity level exceeds trigger point         | Nil                             |
| Construct new assets           | Nil  | Move, typically upwards         |
| Modify assets                  | Nil  | Move, typically upwards         |
| Retrofit hi-tech devices       | Nil  | Move, typically upwards         |
| Operational activities         | Reduce activity level to below trigger point | Nil                             |
| Install distributed generation | Reduce activity level to below trigger point | Nil                             |
| Influence customer behaviour   | Reduce activity level to below trigger point | Nil                             |

Table 29 - Summary of Approaches to Trigger Points

In identifying solutions for meeting future demands for capacity, reliability and security of supply, MLL considers options that cover the above range of categories. The costs and benefits of available options are considered (taking into account the benefits of environmental compliance and workplace/public safety) and the option yielding the greatest cost/benefit ratio will generally be adopted.

#### 4.10 Issues affecting development options

MLL has identified the following issues in regard to its current use of 33kV, 11kV and 11kV SWER configurations:

- The continuing growth of vineyards and dairying into remote areas is likely to exceed the distance over which 11kV lines can adequately supply. To address this and the overall problems associated with load growth in rural areas and the difficulties of constructing new lines, all distribution renewals or extensions outside of urban areas will be at 22kV.
- Load growth in some areas supplied by SWER may merit conversion to single or three phase 11kV or conversion to 22kV. In some cases conversion is also driven by the requirements of regulations.
- The need to rebuild 11kV lines at the end of life or to increase capacity requires consideration of alternative line routes or other options.
- The existing 33kV system is adequate for the life of this plan, however continued load growth beyond this will eventually require an increase in this voltage, or construction of new lines. This is particularly true for longer 33kV lines such as to Rai Valley and Ward. Fortunately these areas are relatively lightly loaded at present. Where appropriate all future 33kV reconstruction overhead or new lines will be built to 66kV. Cabling in central areas will remain at 33kV.
- Further increases in embedded generation are likely to bring some assets to maximum loading, and may require increases in capacity or changes to system configuration.
- Future system development and enhancement is dictated by a number of factors, many of which are outside MLL's control. These include, but are not limited to: changing land use, expansion of the wine and marine farming industries, processing of the significant forestry resource in Marlborough, and general economic growth. It is difficult to predict with any degree of accuracy where and when future system development and capacity enhancements will be required. Accordingly, this plan is revised at least annually and whenever significant change occurs.
- The ten-year capital investment forecasts are based on: in the shorter term, known system expansion requirements, and in the longer term, historic growth in demands.
- Projects will be considered, and options, including non-assets solutions such as distributed generation, will be assessed prior to final budget approval.
- Non-asset solutions, beyond those currently used such as water heating control, are generally easy to implement in the context of a distribution network with a large number of end-users and affected parties. These solutions are generally more

effective at deferring capital expenditure rather than negating the need for expenditure.

- The need for further zone substation capacity is driven directly by the load. Should no further increases occur, then this expenditure will be able to be deferred. There are few easy alternatives to providing more capacity, however where practical, these are taken (e.g. moving load from one substation to another, increasing cooling/capacity of existing transformers). Distributed generation is not sufficiently reliable, diverse or cost effective to be substituted for zone substation transformer capacity. For example, Ward substation has more wind generation connected than load, however its maximum demand is relatively unchanged from before the connection of the wind generation. Further connection of wind generation may require increases in transformer capacity to cope with the generation.
- Most of the capital work detailed below relates to renewal of the existing Network, albeit with lines of higher capacity. In practice, there are few viable alternatives to replacing the line as the need for renewal is primarily a function of aging, rather than capacity. Consideration has been/is given to relocating the line, to deferring the cost where practical, and to changing the voltage. The further development of embedded/distributed generation, is not a viable alternative to renewing the lines as it is not sufficiently diverse (i.e. mainly wind with very small percentage of solar) to provide a reliable alternative to grid supply.
- Line renewal is considerably more expensive than green field construction. Most existing lines were constructed before 1993 and do not have easements. Renewal is only possible with the agreement of the landowner and creation of easements or where it has no adverse effect (greater than existing) on the land.
- The predictions are based on the assumption that the regulatory regime will be such that MLL will be able to earn an appropriate commercial return on all capital expended. If the future regime is such that achieving a commercial return is not possible, then this plan will require revision.

#### **4.11 Embedded generation policies**

Aside from the need to meet increased customer demand in the utilisation of electricity, it also may be necessary for MLL to extend or increase the capacity of its Network to provide for new sources of generation, particularly hydro and wind.

MLL has already extended its Network to enable the connection of wind generation and discussions with further potential generators are on-going.

MLL is committed to facilitating the connection of new generation to its Network subject to generators meeting appropriate technical and commercial criteria. MLL's policies are on the website under "Get Connected".

Embedded or Distributed generation with solar and or wind as the primary energy source is not considered to be sufficiently diverse or reliable enough to reduce or defer capital expenditure. Solar has limited production during the winter months, where MLL's peak loads and highest energy flows occur, while the production from wind is very variable.



Dark (no sun), windless days occur despite Marlborough being one the sunniest regions of NZ and accordingly it is necessary to have sufficient capacity within the Network to cope with days where solar and wind generation is limited.

#### **4.12 Non-network solutions**

MLL has historically implemented a range of non-network solutions including ripple control of water heating, night-store heaters, peak demand tariffs and reactive power tariffs. These legacy solutions have become less applicable as the line and energy segments of the electricity supply chain have been vertically disaggregated. Price signals are sometimes masked by retailers or distorted by government policies on supply and pricing.

MLL recognises the very limited applicability of non-network solutions to growth in constrained areas of the Network. This can be a double-edged sword in that, any reduction of demand (to avoid network Capex and reduce Transpower charges) also reduces MLL's revenue.

In the 2014 year, MLL introduced a demand component charge which is focused on the periods which generally result in chargeable peaks on the Transpower system.

The Transpower charges to MLL are based on MLL loads during the 12 highest Upper South Island loads. In an ideal world, this signal would be passed on to customers "as is", in practice it is difficult to follow changes due to factors beyond MLL's control and consequently a more averaged form is being used to encourage customers to move their load from the periods most likely to result in peak charges.

This type of non-network solution is a longer term solution and if effective generally results in deferral of expenditure rather than removing the need for capital expenditure.

## 5. Capital Expenditure

This section contains details of proposed capital expenditure and the projects and expenditure being considered. Note all values given in this section are shown in today's dollars, i.e. they do not allow for inflation. Figures showing the values in nominal dollars are shown in the disclosure information included in appendix C.



Photo 20 – Cloudy Bay Substation

## 5.1 Network Capital Expenditure Budget 2015 to 2025

The capital budget, based on the information in this Plan and the projects identified above for FYE 2016 to 2025 is shown in Table 30 – Network Capital Expenditure Budget Table 30 below. More detailed information on the 2016 financial year is shown in section 5.2 and in the disclosure information included in appendix C. The values are shown in today’s dollars.

Note that while all projects have been grouped under the main driver in accordance with the disclosure requirements, in practice most projects have a number of drivers and considerations. For example when looking at renewals, priority is given to lines that have poor reliability or where additional capacity offers advantages, such as increased transfer capacity between zone substations.

| Financial Year Ending               | 2016<br>(\$000) | 2017<br>(\$000) | 2018<br>(\$000) | 2019<br>(\$000) | 2020<br>(\$000) | 2021<br>(\$000) | 2022<br>(\$000) | 2023<br>(\$000) | 2024<br>(\$000) | 2025<br>(\$000) |
|-------------------------------------|-----------------|-----------------|-----------------|-----------------|-----------------|-----------------|-----------------|-----------------|-----------------|-----------------|
| Customer Connection                 | 200             | 200             | 200             | 200             | 200             | 200             | 200             | 200             | 200             | 200             |
| System Growth                       | -               | -               | -               | -               | -               | 150             | 150             | 150             | 150             | 150             |
| Reliability, Safety and Environment | 3,468           | 3,330           | 2,945           | 2,795           | 2,095           | 2,480           | 2,100           | 1,600           | 1,600           | 1,600           |
| Asset Renewal                       | 6,155           | 6,030           | 4,250           | 5,800           | 6,125           | 5,600           | 6,600           | 7,100           | 7,100           | 7,100           |
| Asset Relocation                    | 185             | 200             | 2200            | 950             | 1400            | 1400            | 600             | 200             | 200             | 200             |
| <b>Total</b>                        | <b>10,008</b>   | <b>9,760</b>    | <b>9,595</b>    | <b>9,745</b>    | <b>9,820</b>    | <b>9,830</b>    | <b>9,650</b>    | <b>9,250</b>    | <b>9,250</b>    | <b>9,250</b>    |

Table 30 – Network Capital Expenditure Budget

## 5.2 Network Capital Expenditure Programme 2016

The network capital expenditure budget for 2016 is:

| Type                                | Name  | Budget (\$K)  |
|-------------------------------------|---|---------------|
| Consumer connection                 | Transformer and subdivision contributions   | 200           |
| Asset Replacement and Renewal       | 11kV Overhead lines, Distribution substations, Distribution Switchgear, 33kV network.         | 6,155         |
| Asset Relocations                   | Underground Conversions, Roothing Authority relocations, Forestry relocations                 | 185           |
| Reliability, Safety and Environment | Network Automation, SCADA, Tee-joint removal, SWER re-insulation, SCADA Communication Network | 3,468         |
| <b>Total</b>                        |   | <b>10,008</b> |

Table 31 - Capital Expenditure Budget 2016

## 5.3 Consumer Connection

The expenditure for customer connection is mainly that associated with the supply of new transformers and increasing transformer capacity in urban settings.

The possible development of central Blenheim may require alterations to existing 11kV/400V substations. This has been discussed with developers, however no firm plans have been agreed on.

The budget for expenditure related to Consumer Connection is approximately \$200,000 per annum.

## 5.4 System Growth

MLL has invested in its 33kV system and 33/11kV zone substations over the past 10 years. This investment has placed the Network in a strong position to accept further load and development. Because of this, there is no expenditure directly caused by system growth anticipated until 2021. Note prior to that point renewal expenditure or quality of supply expenditure may also provide further scope for system growth and/or remove any constraints in the Network.

Should substantial load beyond that allowed for in this plan unexpectedly arise, MLL will move to meet the demand and accordingly MLL has made provision for new 33/11kV zone substations at locations including Fairhall, Hammerichs Road and Wairau Valley.

## 5.5 Asset Replacement and Renewal

Asset replacement and renewal is the area of greatest capital expenditure. One alternative to renewal is to defer the expenditure, i.e. adopt a 'do-nothing' approach. This type of approach can lead to loss of safety and reliability while generating very high future demands for expenditure and resources, and at the same time reducing the ability of the business to provide these resources.

The approach favoured by Marlborough Lines is to target renewal expenditure to the older parts of the Network where maximum benefits can be achieved. Examples of this include:

- Increases in capacity in areas where loads are limited.
- Areas with small or unusual conductor.
- Lines which can be used to provide interconnection between zone substations of 'n' security in particular between Seddon and Ward, Havelock and Linkwater.
- Lines with pole types which are difficult to maintain e.g. iron rails.
- Lines with high numbers of poles at the end of life and/or red tags and/or conductor prone to failure, i.e. lines with higher maintenance costs.
- Lines which affect the greatest numbers of customers, i.e. 33kV and the beginnings of feeders.

Over the ten year period of this Asset management Plan, Marlborough Lines will invest \$65 million (in today's dollars) in renewing the Network. This makes up the bulk of the capital expenditure for the Network.

### 5.5.1 Subtransmission

#### 5.5.1.1 Redwood Pass Line

The 33kV line to Seddon was constructed in 1927. The section of line from Cloudy Bay Substation to past the Vernon Lagoons is close to the sea and prone to faults due to swans impacting the line. To reduce the number of faults, this section will be reconstructed in triangle construction at 110kV which increases the spacing between conductors. This will reduce both the number of swam strikes, as well as the number of faults from strikes. This project commenced in 2014 and should be completed in 2015/2016. The total budget is \$700K. This job will also remove the last of Mink conductor from the Redwood Pass line, thereby increasing its overall current rating.

#### 5.5.1.2 Waihopai Line Renewal

This line was constructed in 1927 on lattice towers. The towers are now at the end of their life. It is planned to renew the first 7.2km of line from Renwick substation in 2015-2016 and 2016-2017 with a total budget of \$1.9 million. Much of the conductor is quail which has shown problems due to wear at the insulators. Amour rods were fitted to overcome this around 30 years ago, however the conductor, like the

towers is now reaching the end of its useful life. Further renewal is required, however this will be contingent on an agreement being reached with Trust Power, regarding their contribution, as owners of the Waihopai Power Scheme.

#### **5.5.1.3 Old Renwick Rd**

This line was originally constructed in 1927 on concrete poles. In the 1970's intermediate poles were installed and additional circuits were added. This section of line now carries two 33kV circuits, and 11kV circuit and 400V lines. Further subdivision and development is occurring in the area. A budget of \$1.2 million has been provided 2018 to 2020 for the renewal and/or relocation of this line.

#### **5.5.1.4 Alabama Rd**

The 33kV along this road provides the second 33kV supply to Riverlands, Cloudy Bay and the East Coast. The line was constructed in the 1960s using reinforced concrete poles and using concrete poles to 'brace' the poles across the deep culvert. Given the importance of the line, its age and its vulnerability to damage from earthquake (and lateral spread), it is intended to renew this line using more resilient construction.

### **5.5.2 Distribution and LV Lines**

This is the largest single area of expenditure which is consistent with Distribution and LV Lines making up the largest part of MLL's Network. The total expenditure for the ten year period is \$45 million, i.e. an average of \$4.5 million per annum. The age of the Network means that MLL is targeting renewal of 35 kilometres of 11kV line per annum. Priority is given to the oldest sections of line, those with weak or unusual conductor (e.g. No 8 galvanised wire), lines with poor reliability, lines with iron rail poles where access for vehicles is limited, or those where other benefits can be obtained (e.g. transfer capacity to zone substations).

This work generally consists of a number of smaller projects. Examples of some of these projects are:

#### **5.5.2.1 Mahakipawa iron rails**

The 11kV line between Havelock and Linkwater was built circa 1940 and was originally constructed on iron rails poles. Since then, roughly one third of the poles have been replaced with tanalised pine. The line traverses hilly terrain and has poor access. It is proposed to renew the section of this line from Linkwater to Moenui Ridge, i.e. approximately 7.5 kilometres. The first third of this work is due for completion shortly with stage II due for construction in 2015-2016 and stage III due for construction the following year. The budget for this work is \$700K.

#### **5.5.2.2 Wairau Valley**

This line was voltage-constrained and originally built in the early 1950s. It originally had a mixture of reinforced concrete poles with some iron rails. The need to maintain supply at regulation voltage, along with the

age and ability to provide additional capacity for dairy farming and vineyard development, made renewal of this line a priority. This line has now been renewed from Renwick to Anderson's floodway, with some remaining work to renew the section to Hillersden and though the Wairau valley Township as well a section of iron rails near Birch Hill. The total budget for the remaining work is approximately \$2million with the work spread out across the next four years.

#### **5.5.2.3 SH1 – Ward to Seddon**

This section of line is exposed to the weather. It was originally constructed in 1928 on reinforced concrete poles and provides the transfer capacity to Ward substation from Seddon. The first stage of this was completed in 2013/2014 with further work planned in the next three years. It is planned to renew a further 17.5km of this line with a budget of this work is \$1.45 million.

#### **5.5.2.4 French Pass Feeder**

This line was originally built in 1970 on tandalised pine poles. The line is on an exposed ridge and subject to extreme weather. The conductor is at the end of its useful life. A budget of \$1.1 million has been provided to reconstruct the line from Okuri Bay to Deep Bay.

#### **5.5.2.5 Havelock to Rai valley**

This line was originally built in the 1970s on a mixture of iron rails, reinforced concretes and tandalised pine poles with light conductor (e.g. galvanised steel). It provides an important backup supply to Rai Valley and Havelock, but is constrained because of its low current capacity. Much of the rest of the route line has now been renewed with a small section of line in the Canvastown area remaining. A budget of \$1.2 million has been provided for the remaining 5km of line. This is expected to be completed over the next two years.

### **5.5.3 Distribution and LV Cables**

In general, the Distribution and LV cables are much younger and have more remaining life than the overhead lines. Assuming 45 years of life for XLPE cables, then less than one kilometre of cable will need replacement within the next 10 years. Some concern has been expressed that some generations of XLPE cable may have a maximum useful life of 35 years. If this proves to be true, then MLL will need to renew 13 kilometres of 11kV line within the next 10 years. LV cable will generally be renewed on failure or when the 11kV cables are renewed.

Part of the work being undertaken to improve quality and reliability of supply will involve removing tee-joints from 11kV cabling and installing RMUs as well as additional cabling to ensure, as much as is practical, that all significant 11kV cables have n-1 security.

The total budget for renewal of distribution and LV cables for the next ten years is \$3.4 million.

#### **5.5.4 Distribution substations and transformers**

In addition to the annual budget for renewing old transformers, this AMP includes provision to renew four of the 11kV/415 substations which supply central Blenheim, i.e. Wynen St, Kinross St, Seymour St and Arthur St substations. These substations have older, less safe technologies such as open bus 415V switchboards and oil filled circuit breakers. They are important in maintaining supply to Blenheim's central business district.

It is intended to upgrade the 11kV switchgear to modern equivalents, the switchboards to metal-clad boards with circuit breakers, and where possible, to install dual 11kV/415V transformers. The total budget for upgrading these substations is \$1.6 million and the expenditure is spread over the first five years of this plan.

The total budget for renewal of distribution substations and transformers for the next ten years is \$3.2 million.

#### **5.5.5 Distribution switchgear**

There is a small allowance for renewal of Distribution switchgear under renewal, however much of this expenditure is included under Quality of Supply, as the main driver for replacement is better reliability (older switchgear is much less reliable) and the ability to remotely monitor and control the switchgear (SCADA).

The total budget for renewal of Distribution and LV switchgear for the 10 year period is \$3.8 million.

### **5.6 Asset Relocations**

There are three main sub-categories within this area of expenditure: roading authority relocations, forestry relocations and conversions from overhead to underground. The total budget allocated to this is \$6.4 million for the period of this AMP.

#### **5.6.1 Roothing authority relocations**

Projects within this group are all driven by outside agencies, such as Marlborough Roads and provision can only be made where MLL is aware of their plans. MLL has only limited influence on the timing of this work.

#### **5.6.2 Forestry relocations**

This stream of work is associated with relocating lines within commercial forestry blocks to reduce vegetation control costs, reduce fire danger and, to allow landowners to better utilise their properties.

In the 2014/2015 year, MLL installed a section of Hendrix spacer cable system. This system provides a semi-insulated overhead cable which it is hoped will reduce the fire risk and improve the reliability of supply in forested area.



### 5.6.3 Underground Conversions

These projects involve the conversion of existing overhead to underground lines. There is a \$100,000 provision for a number of smaller projects each year. Consideration has also been given the following major projects:

#### 5.6.3.1 Undergrounding of Redwood St from Horton Park to Ida Street

Redwood St has one of the highest traffic densities in Blenheim. The estimated cost of undergrounding this section is \$1.0 million. Undergrounding offers improved public safety, a cleaner visual environment, and better reliability. This work is contingent on the participation of the Marlborough District Council.

#### 5.6.3.2 Murphys Rd Undergrounding

Murphys Rd has high traffic volumes and is used by heavy trucks to avoid the Grove Rd Bridge. The street contains a primary school and pre-school. The poles in Murphys Rd carry two 33kV circuits supplying a large portion of MLL's Network, as well as an 11kV feeder and 415V circuits. Damage to any of these poles may severely compromise the ability of the Network to deliver service. In addition undertaking maintenance or work on poles is very difficult. To improve public safety, and reduce the risks to the Network consideration is being given to undergrounding the overhead lines. The estimated cost of this project is \$1.2 million. Note \$1.2 million has also been allocated to the renewal of the 33kV circuits, making the total budget for this project \$2.4 million.

#### 5.6.3.3 SH1 Bridges – Wairau River and Opawa River

A budget of \$0.8 million has been allocated to converting the existing overhead lines to higher capacity underground cables attached to the bridges as part of the bridge redevelopment work proposed by Transit New Zealand.

#### 5.6.3.4 Havelock North and South End

A budget of \$0.7 million has been allocated to converting the existing overhead lines to underground cables at the North and South Ends of Havelock, i.e. extending the area of undergrounding. The lines at the North End are located close to the road and vulnerable to damage from vehicles.

## 5.7 Quality of Supply

MLL places great emphasis on reliability of supply and systematically investigates all interruptions to identify the source of interruption. Trees and vegetation are one of the main causes of faults, in particular plantation forests. An increase in harvesting activities as forests mature has led to loss of supply for two main reasons: trees, ropes etc contacting lines during harvesting and, trees falling over as harvest results in increased exposure to wind loadings. The latter occurrences can typically result in prolonged outages.

The current tree legislation only provides for minimal, and sometimes impractical, distances between lines and trees. In many situations the trees are close to and considerably higher than the lines.

One of the major areas of focus for capital expenditure for 2016 to 2025 is reliability.

With ever increasing customer expectations of improving service against a backdrop of lines and cables with an increasing average age means that expenditure needs to be directed towards, at least, maintaining reliability and preferably improving service.

Expenditure around safety will primarily be associated with operational expenditure (to remove immediate hazards) or line renewal (where line age means that its integrity is compromised and it needs renewal).

Environmental expenditure tends to be associated with projects with other main drivers, e.g. line renewals. Where Marlborough District Council is prepared to contribute towards converting overhead to underground, this work will proceed, however there is currently no agreement to undertake any further work of this type. The last project of this type is the undergrounding from Murphys Road to the new Outer Limits Development, on the main road into Blenheim from Nelson.

### 5.7.1 SCADA

Supervisory Control and Data Acquisition (SCADA) provides the ability to remotely control and monitor equipment. There are three essential parts of a SCADA system:

- central computers which provide the Human Machine Interface (HMI) giving alarms, graphs, data, control etc
- communication system which talks from the central computer to devices
- remote terminal units (RTUs) which interface the communications from the remote equipment to the central computers.

Of the above, the communication system is the highest value and provides the greatest challenges in maintaining a reliable, functional and secure SCADA. Traditionally MLL has used cellphone technology to provide SCADA to remote sites, however in the event of a widespread emergency, the cell network has proven to be vulnerable to overloading. This occurs at precisely the time when a SCADA system has maximum value.

To overcome this, MLL has been developing a high bandwidth reliable licensed radio system. Currently repeaters are operational at Kaituna, Jamies Knob, Takorika, Saddle Hill, Stevens Hill, Weld Cone, Vahalla Ridge and Otukakau. Further extension of the SCADA network requires repeaters to be installed at Whatamonga, Arapawa, Portage, Bulford and Kaiuma. MLL is working to obtain all of the required approvals to allow development of these repeaters.

The total budget for the extensions of the SCADA system to cover the existing and new reclosers is \$3.4 million with \$990,000 included in the 2015/2016 budget.

## 5.7.2 Network Automation

Network automation allows for the supply of electricity to be made more reliable, while reducing the costs of operating and the time to restore faults. Better control and information improves safety and, with accurate information on Network performance, allows improvements in asset management. Note the investment in SCADA is important in gaining maximum value from investment in Network Automation. The total budget allocated to network Automation over the next ten years is \$10.4 million.

### 5.7.2.1 Reclosers

Reclosers are an essential part of an overhead distribution system. They automatically restore power following a transient fault (such as lightning or possum contact). Since approximately 90% of faults are transient, reclosers help maintain a reliable supply.

Renewing older reclosers with more reliable modern equivalents offers a number of advantages such as better reliability, and ability to remotely monitor and control (e.g. applying reclose blocks), better information of faults and the ability to have co-ordinated operation (referred to as “smart networks” or Network Automation). Remote control also offers the ability to alter settings remotely. This is useful when work is being undertaken in the area, e.g. vegetation control and/or if conditions such as fire risk require changes. It also allows settings to be changed when the Network configuration is altered.

Consideration is also being given to new technologies, such as pulse reclosers which check for faults with short duration pulses before reliving lines.

In addition, the ability to remotely operate the reclosers allows them to be installed in better locations as the need to access them for operation was often a determining factor in their location.

In total, \$1.5 million is allocated to new or replacement reclosers, providing 30 reclosers within the period of the AMP. \$400 is allocated to the 2015/2016 year to provide eight reclosers controlled by the SCADA system.

### 5.7.2.2 Switching Structures

Marlborough Lines has 33kV switching structures at Long Valley, Tuamarina, Jacksons Ford, Renwick, Riverlands and Seddon where the equipment is at the end of its useful life. These structures were designed and built when it was relatively easy to arrange extended outages for maintenance. They are constructed in ways which don't allow live line work and/or maintenance on one 33kV circuit with the second circuit alive. It is planned to replace the existing 33kV air break switches with 33kV RMU. This will allow maintenance as well as remote indication and operation. The total budget for replacing Tuamarina,

Riverlands, Seddon, Long Valley, Jacksons Ford and Renwick is \$1.9 million.

#### **5.7.2.3 Spur Line fuses/Fuse-savers**

Additional spur line fuses allow for faults to be more localised, i.e. areas affected to be reduced, while at the same time offering better isolation for fault finding. Fuse-savers limit fuse operation for transient faults, i.e. they save the fuse and reduce visits to install new fuses. In total \$1 million is allocated to spur lines fuses and fuses-savers over the 10 year period of this plan, i.e. \$100,000 per annum.

#### **5.7.2.4 Fault Indicators/Power Alarms/Smart Meters**

Fault indicators indicate fault currents in lines. This allows for better fault finding and sectionalising. Power alarms provide an alarm if the voltage goes out of bounds or fails.

The fault indicators currently installed within MLL's Network are aging. They flash when they detect a fault and are therefore only provide information when visited just after a fault has occurred.

The power alarms rely on the phone to ring a central computer and advise of abnormal voltages. This equipment is also aging. Consideration is being given to replacing these with smart meters which could directly interface with MLL's outage management system.

With the further spread of the SCADA system, it is planned to upgrade these devices to allow communication with the SCADA and the provision of more timely information. A total budget of \$1.0 million is allocated to upgrading these devices.

### **5.7.3 Alternative Supplies**

This item of expenditure is where the main driver is the provision of an alternative supply or improved security of supply. The alternatives to this are to accept a lower security of supply (i.e. do nothing) or provide security of supply in other ways, such as through the provision of reliable distributed generation of sufficient capacity. Major projects in this sub-grouping are:

#### **5.7.3.1 Montana 33kV cable**

This cable provides an alternative 33kV supply to Cloudy Bay substation and the East Coast. It will be built along the main road and give geographical and physical diversity to the 33kV supplies (which are currently on dual circuits alongside each other). The budget for this is \$380K and it is expected to be completed in 2015/2016.

#### **5.7.3.2 Waikawa cable**

The Waikawa feeder from Picton supplies 1985 customers, this is more than any other single feeder. This feeder is radial and relies on a single line. The next largest radial feeder is the Kenepuru feeder, which has a

total of 1105 customers. By way of comparison, the Waikawa feeder has 1447 customers using more than 3000kWh per annum, while the Kenepuru has 471 customers using more than 3000 kWh, i.e. the Kenepuru has more holiday homes.

While the precise use of an installation is irrelevant to the performance figures such as SAIDI, clearly feeders with more people in residence are more affected by faults than those where people are absent. For this reason, development of an alternative supply to Waikawa is important in maintaining overall Network performance as well as reducing disruption to the community.

Consideration has been given to a number of possible routes and also to the installation of diesel generators. The load is such that very large diesel generators would be required and this is not considered to be a good alternative to the installation of cable.

MLL intends to install a 33kV cable to the far end of Waikawa in conjunction with MDC plans to install additional water/wastewater services in Waikawa road. In addition, provision has been allowed for the installation of a 33/11kV substation and 11kV circuit breakers.

The total budget allocated to this is \$1.25 million spread across the 2017 to 2020.

#### **5.7.3.3 Off Grid Supplies**

There are a number of circumstances where long lines, often through difficult and/or forested terrain supply 3 or less customers. One such line is 10km long on iron rails through commercial forestry and it supplies a single installation which only has occasional occupancy. Where practical MLL are looking at moving these customers to a hybrid off-grid supply using PV arrays and diesel backup generators.

There is a budget of \$80K allocated to this type of project in the 2015/2015 financial year.

### **5.8 Legislative and Regulatory**

This area of expenditure is related to the need to comply with legislation and/or regulations and in particular where these change and require expenditure. MLL's Network is compliant with existing legislation and regulations. Safety and the need for compliance is integral to the way we operate and any non-conformances are dealt with as a priority. As the existing network is compliant, expenditure in this area is very low. A nominal budget of \$50K per annum has been allowed for minor activities.

### **5.9 Other Reliability , Safety and Environment**

This area of expenditure is related to safety, environment or reliability and not covered by earlier sections such as supply quality. A total budget of \$4.9 million spread over the next ten years has been provided for this. There are three main activities, Substation earthing, tee-joint removal and SWER re-insulation.

### 5.9.1 Substation Earthing

There are three main projects in this section.

In 2014/2015 MLL commissioned a ground fault neutraliser at Havelock substation.

This type of earthing reduces fault currents and EPRs, while allowing the feeder to remain alive with a single fault. This also reduces EPR and the risk of starting a fire. The Havelock GFN has been successful and accordingly it is planned to install GFNs at Spring Creek, Linkwater and Rai valley substations over the next 6 years. The total budget provided for this is \$1.5 million.

### 5.9.2 SWER Re-insulation

A tragic fault in north Canterbury resulted in the death of a farmer tending to his livestock. The line was damaged due to an earth fault allowing the live SWER conductor to drop. One way to reduce the risk of this occurring is to increase the separation between the live conductor and the wooden poles. MLL are planning to do this, with priority given to areas with higher risk, i.e. those with greater nearby population and/or more intensively farmed. A total budget of \$720K has been provided with \$120K in the 2015/2016 year.

### 5.9.3 Tee Joint Removal

This stream of work is to remove tee-joints from the LV network and to break any subdivisions reticulated in this manner down into more manageable sections.

The budget for this work is a total of \$680K for the next 10 years, with \$250,000 budgeted for years 2016/2017 and 2017/2018.

## 5.10 Non Network

Non Network expenditure consists of expenditure on office buildings, Plant, tools, Test equipment, Vehicles and Information Technology. Over the next ten years \$15 million is allocated to this, i.e. approximately \$1.5 million per year.

The forecast for next 10 years is based on actual spend over the previous 5 years plus allowance for:

- **Software**

Replacement of the Asset Management software. This project is expected to be completed within the next year. \$500,000 has been budgeted for the completion of this project. Beyond that, further allowance has been made for smaller developments of standard software and mobility solutions.

- **Land and Buildings**

MLL is currently undertaking a programme of works to assess key structures and their vulnerability to failure under severe seismic loading. In accordance with current and relevant structural design standards, detailed seismic assessments will be carried out on structures to determine their rating in accordance with the National Building

Standard. Where structures are deemed to be Earthquake Prone (i.e. NBS <34%), seismic strengthening works will likely be undertaken to improve the structural performance and conform to current design levels. Strengthening works may still be undertaken on structures that are rated as Earthquake Risk (i.e. >34% NBS) – this will depend on the actual rating and the function of the structure.

- **Vehicles**

The projection allows for the cyclical replacement of the existing Network Fleet.

- **Plant and Equipment**

The projections allow for the replacement of computer server infrastructure (\$400K) each five years, and the cyclical replacement of other computer hardware. The regular replacement of plant, test and office equipment is also allowed for.

## 6. Lifecycle planning

Deterioration of assets can be caused by a number of factors, some of which include:

- Number of operations (e.g. switchgear, tap changers).
- Loading and duty cycle (e.g. transformers).
- Environment (such as salt laden air), wind, snow, ice.
- Age (typically embodying number of operations, exposure to environment and weathering).
- Lack of prudent maintenance.

Critical assets must be maintained to reverse the effects of this deterioration, and extract maximum benefit from their continued operation. This involves assessing asset condition and performing corrective action based on these assessments.

In addition to work on assets, it is also necessary to maintain access to the assets and the environment around the assets (for example keep trees clear of overhead power lines). For MLL, a part of the maintenance budget is allocated to the maintenance of access tracks and vegetation control.

### 6.1 Key Drivers

MLL undertakes a condition-based maintenance program centred around regular inspection and testing of Network equipment. The programme has the following major aims:

- To ensure the safety of staff and the general public.
- To achieve a reliable, secure system in accordance with service levels and customer expectations.
- To comply with all aspects of our environmental policy.
- To identify required corrective maintenance before failure.
- To minimise the total cost of ownership of assets.

MLL endeavours to achieve these aims, while ensuring that unnecessary maintenance is avoided. It is a process of continuous improvement, and one that will become more effective over time, as more history is collected about equipment and failure modes. MLL also endeavours to buy quality new equipment with minimal maintenance requirements to assist with future reliability.

Typical maintenance tasks include the following classes of activities:

- Checking and replenishment of oil, grease and insulation components such as oil, SF6, vacuum and grease.
- Checking, minor repairs or replacement of semi-consumable components e.g. brushes, contacts, gaskets, seals.
- Checking and minor repairs to breakable components e.g. sight glasses.
- Calibration of components such as thermo-couples, relays.

The key criteria for these tasks are that they restore the original service capacity - they do not increase that capacity.

## 6.2 Key Assumptions

This plan assumes:

- That customers will continue to want and be willing to pay for a reliable power supply based on the MLL Network. The amount of maintenance is consistent with the objectives of maintaining a safe and reliable Network which meets the needs of customers and stakeholders.
- That the current regulatory framework will continue, albeit with some changes and refinements.
- That no major disasters or widespread systemic problems will occur and that load growth will be consistent with values elsewhere in this plan and spread across the region.
- Introduction of distributed generation in the next 10 years will not affect asset deployment.
- That no major new loads or major generation will be installed.

## 6.3 Asset replacement and renewal policies

When assets near the end of their useful lives, the costs of operating and maintaining them increase quickly. The risks associated with the assets also increase as the number of asset failures increase.

MLL policy is to obtain maximum value from each asset, without compromising safety and reliability. Much of the existing Network was developed in the 1960s and 1970s and accordingly would, without prudent maintenance, reach the end of its useful life over a short span of time. Marlborough Lines recognises this and its policy is to spread expenditure so as to minimise the variations year to year. It is possible to defer this type of



expenditure, however that runs the risk of large scale failures with inadequate resources available to correct the problem.

It should also be noted that replacement of assets is not always straightforward, and that consultation with stakeholders is important, e.g. landowners can sometimes make replacements a long and drawn out process. MLL must maintain the capability to replace its assets if it is to remain a viable business into the future.

In general, asset replacement and renewal is targeted towards areas where other drivers exist, for example low capacity or low strength lines, ties between substations without (n-1) reliability, safety concerns, and/or assets that are expensive or difficult to maintain (e.g. iron rails).

Consideration is given to making assets ‘smarter’ on renewal. Developments in smart grid technologies are making new assets easier to monitor and operate remotely. In general, remotely monitored and operated equipment assists in achieving all the aims of the maintenance programme described in section 6.1.

Looking at the remaining useful lives of the assets, the renewal requirements for major asset categories are shown in the table below:

| Asset Category                    | Quantity in next ten years | Quantity for 10 to 20 years | Quantity 20 to 30 years | Notes  |
|-----------------------------------|----------------------------|-----------------------------|-------------------------|--|
| 11kV Distribution Lines           | 370km                      | 770km                       | 460km                   | LV renewed at same time  |
| Distribution transformers         | 200                        | 400                         | 700                     | Done as required   |
| 11kV Distribution Cable           | 1km                        | 12.5km                      | 22.5km                  | LV renewed at same time  |
| Zone substations                  | None                       | none                        | none                    | Historically upgraded due to load, rather than age                           |
| Zone substation transformer stock | 7                          | 2                           | 5                       | Older units are mainly smaller and are at substations with (n-1) reliability |

Table 32 – Renewal requirements for major asset categories

A previously unknown potential catastrophic failure mode has been identified in some Long & Crawford make oil switches. MLL has three of these switches still in service. These have been programmed for replacement with SF<sub>6</sub> switches in 2015. In the interim, a change in operating procedure has been applied in order to mitigate the immediate risk.

#### 6.4 Routine & corrective maintenance & inspection policies

Preventative maintenance is planned annually and scheduled on a monthly basis. The table below outlines the regimes, and the frequencies at which inspections and testing are done.

| Regime   | Frequency |
|--|-----------|
| Zone Substation and Regulator Site Inspections | Monthly   |
| 33kV Lines                                     | Annually  |

| Regime                                     | Frequency   |
|--|---|
| Major Distribution Substation Inspections  | Varying 1-5 years   |
| Ground Mount Switch Inspections            | Varying 1-5 years   |
| Pole Mounted Circuit Breaker Inspections   | Annually  |
| Earth Testing                              | Annually for safety-critical sites, 33kV ABS switches, 33/11kV subs (e.g. near schools) and zone substations, 3 yearly for SWER and 6 yearly everywhere else. |
| Asset Condition Survey (Poles & Lines)     | Approx 5 yearly   |
| MDI Readings                               | Varying 1-12 months   |
| Safety Inspections (Aerial Crossings etc.) | Annually  |
| Thermovision                               | Annually  |
| Partial Discharge (PD) Survey              | 3 yearly for Zone substations, 6 yearly for major distribution substations and ground mount switches  |
| DGA Testing                                | varying 6-18 months   |
| Tree Maintenance                           | As required   |
| Diesel Generator Inspections               | Annually  |

**Table 33 - Key Preventative Maintenance Regimes**

Most of the preventative maintenance is planned using the WASP Maintenance Module. This involves the setup of regimes, and the adding of assets to these regimes. Each month, work packs are generated for maintenance that is due. WASP stores asset “triggers”, effectively storing a date which shows when the next maintenance is due. When the work packs are created, this “trigger” is reset to the next date, based on a frequency stored within the regime.

Corrective maintenance is planned using a risk-based approach. Corrective tasks are identified and are added to the “Task Pool” in the WASP Maintenance Module. Tasks are automatically prioritised using a combination of asset criticality (ACR) and task criticality (TCR).

The ACR for a particular asset encompasses the weighted average of five factors: number of customers, safety, environment, degradation and cost of replacement. This is automatically calculated from parameters stored within the system. TCR is an assessment of “days to fix” for a particular task, based on what the field inspector perceives at the time when the maintenance is identified. The combination of ACR and TCR creates a RPN (Risk Priority Number) which is used to generate a report, showing a prioritised list of corrective maintenance tasks.

The risk based approach gives priority to serious defects, assets serving large numbers of customers, specific high-value customers, or places where public safety is a concern. It also results in low-priority assets effectively being operated on a “run-to-failure” regime. This system ensures that at all times, corrective maintenance is being performed efficiently and the most critical tasks are the ones being focused on.

MLL has also implemented a more efficient outage planning system. For each corrective maintenance task in the “Task Pool”, a maintenance icon appears on the GIS system, directly on top of the defected asset. This enables corrective maintenance to be visually identified and scheduled alongside known planned outages, thereby improving efficiencies.

Over the next two years, this functionality will be shifted into the new asset management system, Infor EAM. The new software will allow field assessments to be recorded on electronic tablets rather than the current paper based system. This shift to ‘go mobile’ will see a decrease in overheads associated with data processing and allow for faster communication of asset health through to management.

A review of maintenance regimes is currently being undertaken. This has been timed to coincide with the upgrade to Infor EAM. As a part of this review, our testing and inspections regimes are being documented in what will become the MLL Maintenance Standard.

## **6.5 Systemic Failure Identification**

MLL records component failures and investigates possible systemic or type faults if recurring patterns are identified. To assist in this, regular meetings are held to review and debrief faults and equipment failures.

## **6.6 Testing and Inspection Regimes**

### **6.6.1 Zone Substation and Regulator Site Inspections**

This regime provides the condition assessment for some of the Network’s most critical assets. Inspectors gather up to 100 different pieces of data per substation, and they also report on the perceived condition of all equipment. The inspections are intended to function as an early warning for potential problems that may occur, as well as a means of capturing data that is currently unavailable via the SCADA system.

No systemic problems have been uncovered in recent history. Various minor defects are often identified, including saturated silica gels, oil leaks and faulty indication. These tasks are given to contractors to investigate and repair.

### **6.6.2 Major Distribution and Substation Inspections**

With a large percentage of revenue coming from major customers, it is important that their electrical assets are kept in good condition. Transformers used for large industrial loads are generally exposed to harsher operating conditions than residential transformers, making it even more critical that they are regularly visited and tested. MLL’s routine inspections involve visual checks and data capture, as well as oil testing for transformers greater than 500kVA. This combined information gives a strong indicator as to the internal health of the transformer, enabling planning to be done for future transformer changes.

Generally the inspections have revealed the population of large transformers to be in relatively good condition. A few transformers have failed crackle tests, and some have had oil leaks which ultimately (if left) could have had significant consequences. These transformers have either been replaced, or are in the

corrective maintenance Task Pool and will be replaced in the near future when they reach the top of the priority list.

### **6.6.3 Ground Mount Switch Inspections**

Being an operable asset, it is important that ground mount switches (sometimes referred to as ring main units) are regularly visited to ensure the safety of the staff who operate them. Small tolerances within ground mount switches mean that oil level or SF<sub>6</sub> gas pressure becomes a critical component to the safety of the operator. MLL recognises this, and as a consequence, has set up a regime to regularly inspect ground mount switches. In locations where an oil switch neighbours a transformer, the two are inspected together.

### **6.6.4 Pole Mounted Circuit Breaker Inspections**

Pole mounted circuit breakers are a difficult asset to inspect, and therefore little more than visual checks can be done. If the circuit breaker can be bypassed, inspection staff by-pass it and perform a trial operation to ensure that the mechanisms are operating correctly. MLL keeps a service history of circuit breakers and this is used alongside visual inspection results and operational information to assess whether circuit breakers need to be replaced.

MLL is currently undertaking a programme to remove all remaining Coopers KF and KFE reclosers from the Network. These circuit breakers are approaching the end of their lives, and, in some instances, are becoming quite unreliable. They are being replaced with newer model circuit breakers with remote operation and monitoring.

### **6.6.5 Earth Testing**

In general earth testing is performed on a six yearly basis. Zone substations and assets in/near public areas, such as shopping centres and schools, are tested every year. SWER substations will be tested every three years. Testing is done by area and environmental conditions are recorded at the time of testing. Results are used to detect unsatisfactory readings and poor earthing areas so that future corrective action may be taken. MLL is rolling out a new testing procedure to better measure the earth resistance at SWER substations.

An engineering review of Zone substation earthing systems is undertaken every eight years, with the next one occurring in 2015. This review identifies earth grid voltage rise, the location of earth potential rise (EPR) contours, touch and step voltages within and around the substation and the effects of EPR on nearby telecommunications systems.

Currently work is being undertaken in response to the new draft EEA guide to power system earthing and new changes in regulations. This work will result in a new MLL Network Standard for earthing, as well as determining the corrective action required on earths based on their historical test results. Currently resources are being applied to collecting testing data, but as the Network standards are finalised, resources will be shifted to correcting earth banks which do not meet the new requirements.

#### **6.6.6 Asset Condition Survey (Overhead Lines)**

All poles in the Network are visited on a regular basis and a visual assessment is done to assess the condition of each pole and the other equipment on it. This data is essential for detecting areas of the Network that are showing the effects of age, and also to detect problems before they become serious. This data has recently begun to be captured in WASP, and the history which will be built up, will provide an essential planning tool for the future.

Poles and equipment are given a condition assessment score of 1-5. This history is being built up over time in WASP, and this historical data will enable thematic maps to be created, highlighting the condition of equipment in various areas of the Network.

Field trials have determined the success and cost effectiveness of helicopter video assessment. As part of this process the video is linked to GPS data so that any remedial work can be readily affected.

MLL has purchased GPS equipment which enables data capture and in-field photo attachment. This equipment has also eliminated the need for paper inspection forms in the field and will eliminate the data entry that has previously been required.

#### **6.6.7 MDI Readings**

Maximum Demand Indicator (MDI) readings are performed on all large distribution transformers to assess capacity usage. The frequency of the readings increases as the transformer capacity margin decreases. Recently MLL has bought some advanced electronic loggers which will provide load profile data rather than peaks only. MDIs are gradually being replaced by these new loggers.

#### **6.6.8 Safety Inspections**

Regular safety inspections of all aerial crossings and boat ramps are done to ensure that signage is visible and that clearances are at safe levels. This is carried out annually prior to the summer boating season.

Similarly, inspections of lines and network equipment near schools are undertaken at least annually.

#### **6.6.9 Public Places Inspections**

MLL has an inspection regime to visit public places where there is high foot traffic, such as shopping areas, to ensure that all electrical equipment in the vicinity of these areas is safe and in good working order. This is part of MLL's Public Safety Management System.

#### **6.6.10 Road and Rail Crossings**

During the last year, all road and rail crossings in the Network have been measured. Crossings which did not meet ECP requirements were identified and corrected. An ongoing program is in place to monitor all crossings.

### 6.6.11 Thermovision Surveys

Annual thermovision surveys are performed on all major lines and zone substations. A full report is created after this survey, identifying all hot spots located in the Network. The identified tasks are prioritised and corrected.

### 6.6.12 Partial Discharge (PD) Surveys

PD is defined as a “localised electrical discharge that only partially bridges the insulation between conductors and cannot occur adjacent to conductors”. PD can manifest itself visually in the form of corona and surface tracking or acoustically both within and outside the realms of human hearing. PD testing methods utilised by MLL are generally non-destructive and non-invasive and can be used to identify faults in electrical insulation at a very early stage.

Partial discharge testing can be undertaken on most electrical assets. MLL focuses routine testing on Zone substation plant and switchyards, major distribution substation plant and ground mounted switches.

PD surveys have often identified issues with cable terminations on ground mount switches. The identified tasks are prioritised and corrected.

### 6.6.13 DGA Testing

Dissolved Gas Analysis (DGA) testing is used to monitor condition of Zone Substation Transformers and Tap-changers. It is one of the tools used to assess the internal health of the equipment and provides a basis for scheduling maintenance. Transformers with poor DGA readings are scheduled for refurbishment or oil filtering, and Tap-changers with poor DGAs are scheduled for overhaul. An increase in the frequency of DGA testing can also be used to trend the aging of a poorly performing transformer.

Note the results of most recent DGA testing are included in section of this plan.

### 6.6.14 Trees

The current tree legislation came into effect on 1 July 2005 and requires all trees to be kept to a certain distance from overhead power lines. The legislation requires lines companies to advertise suitable safety information to tree owners as well as contacting tree owners when their trees are close to power lines.

Each tree owner has the option of taking ongoing responsibility for keeping the tree outside the minimum distance, or granting the line owner approval to keep the tree outside the minimum distance by appropriate pruning or removal. The cost of first pruning is to be met by the lines company, as is the cost of the record keeping, liaison and advertising.

In practice, this legislation is not leading to good outcomes. The growth limit zones are barely adequate for ensuring safety of the public in relation to trees, however in many cases they do not protect the lines from trees and or inhibit the risk of fire. In addition, the complex formulas require detailed and costly survey work to be undertaken if landowners require strict adherence to the legislation.

The inadequacy of the Tree Regulations in rural and forestry areas is of real concern to MLL to the extent that MLL filed proceedings seeking a Declaratory Judgment in relation to various aspects of the Regulations and to protect the Network from interference from trees to maximise reliability and prevent fires.

In 2011 and 2012, MLL inspected all lines annually for tree interference, typically using a video / GPS system from a helicopter together with ground inspections. Since 2012, 33kV lines are inspected annually and other lines are inspected on a rotational basis dependant on priority.

Trees are one of the significant causes of outages on the Network. The current tree legislation only permits minimal clearances and removal of vegetation. In areas of high growth, this means that the limits are quickly exceeded after trimming, thereby requiring frequent return visits and high ongoing costs. These costs are further exacerbated in the remote area of MLL's network where access is difficult and expensive.

Despite the inadequacies of the tree legislation, MLL has directed its efforts to minimising outages and where possible obtaining greater clearances than those provided by the legalisation.

Upon advice from the Rural Fire Authority, MLL inhibits the automatic reclosure of supply at times of specified high fire risk. This action has the potential to result in prolonged outages but such is in the best interest of the public overall if fires in high risk areas can be avoided.

#### **6.6.15 Diesel Generator Inspections**

Two new testing regimes are being set up for MLL's fleet of diesel generators. The first is a monthly visual inspection and brief run test. This inspection is intended to keep the generators in a ready to operate state. The inspection is to be included as part of the usual pre-start checks. This means that the inspection will only be triggered if a generator has not been operated for an entire month.

The second inspection is an annual electrical inspection and loaded test run. The inspection utilises thermal imaging to monitor the wear on electrical connections which present themselves as thermal hotspots when the generator is loaded. Battery tests, winding resistance tests and the replacement of the 11kV terminations are also part of this inspection.

### **6.7 Operational Expenditure**

Maintenance expenditure is planned consistent with prudent and timely maintenance of all elements of the Network. It is MLL's firm view that deferral of prudent maintenance will ultimately incur much greater costs.

Our maintenance programme is determined in conjunction with best industry practice, regulatory requirements, manufacturer's recommendations, and continuous surveillance of the Network. Overall we anticipate similar maintenance levels each year, but because the magnitude and frequency of unforeseen events cannot be predicted, estimation of expenditure is determined relative to previous history and can be subject to significant variation from one year to the next.

The estimated maintenance expenditure for the next five years is shown in the table on the following page, and is based on current estimates. These estimates factor in previous history, growth expectations and known condition of assets.

The values given in Table 34 are in today's NZ dollars, i.e. no allowance for inflation has been included.



| Item  | 2015/2016<br>(\$000) | 2016/2017<br>(\$000) | 2017/2018<br>(\$000) | 2018/2019<br>(\$000) | 2019/2020<br>(\$000) | 2020/2021<br>(\$000) | 2021/2022<br>(\$000) | 2022/2023<br>(\$000) | 2023/2024<br>(\$000) | 2024/2025<br>(\$000) |
|---|----------------------|----------------------|----------------------|----------------------|----------------------|----------------------|----------------------|----------------------|----------------------|----------------------|
| Service interruptions and emergencies             | 900                  | 900                  | 900                  | 900                  | 900                  | 900                  | 900                  | 900                  | 900                  | 900                  |
| Vegetation management                             | 2,440                | 2,440                | 2,440                | 2,440                | 2,440                | 2,440                | 2,440                | 2,440                | 2,440                | 2,440                |
| Routine and corrective maintenance and inspection | 2,700                | 2,700                | 2,700                | 2,700                | 2,700                | 2,700                | 2,700                | 2,700                | 2,700                | 2,700                |
| Asset replacement and renewal                     | 215                  | 215                  | 215                  | 215                  | 215                  | 215                  | 215                  | 215                  | 215                  | 215                  |
| <b>Network Opex</b>                               | <b>6,235</b>         | <b>6,235</b>         | <b>6,235</b>         | <b>6,235</b>         | <b>6,235</b>         | <b>6,235</b>         | <b>6,235</b>         | <b>6,235</b>         | <b>6,235</b>         | <b>6,235</b>         |
| System operations and network support             | 1,925                | 1,925                | 1,925                | 1,925                | 1,925                | 1,925                | 1,925                | 1,925                | 1,925                | 1,925                |
| Business support                                  | 3,500                | 3,500                | 3,500                | 3,500                | 3,500                | 3,500                | 3,500                | 3,500                | 3,500                | 3,500                |
| <b>Non-network opex</b>                           | <b>5,425</b>         | <b>5,425</b>         | <b>5,425</b>         | <b>5,425</b>         | <b>5,425</b>         | <b>5,425</b>         | <b>5,425</b>         | <b>5,425</b>         | <b>5,425</b>         | <b>5,425</b>         |
| <b>Operational expenditure</b>                    | <b>11,660</b>        | <b>11,660</b>        | <b>11,660</b>        | <b>11,660</b>        | <b>11,660</b>        | <b>11,660</b>        | <b>11,660</b>        | <b>11,660</b>        | <b>11,660</b>        | <b>11,660</b>        |

Table 34 – Estimated Operational Expenditure 2015 to 2025

## 6.8 Renewal Expenditure

Renewal expenditure consists of capital expenditure associated with asset replacement as well as operational expenditure. In general the difference is determined by whether a complete asset, e.g. 4km of 11kV line, is being renewed (capital) or just parts of an asset, e.g. a single pole is being replaced (operational). These values are also given elsewhere in this plan; however the table below shows the total renewal expenditure:

| Renewal Expenditure     | 2014/2015 (\$000) | 2015/2016 (\$000) | 2016/2017 (\$000) | 2017/2018 (\$000) | 2018/2019 (\$000) |
|-------------------------|-------------------|-------------------|-------------------|-------------------|-------------------|
| Operational Expenditure | 210               | 215               | 215               | 215               | 215               |
| Capital Expenditure     | 5,255             | 6,155             | 6,030             | 4,250             | 5,800             |
| <b>Total</b>            | <b>5,465</b>      | <b>6,370</b>      | <b>6,245</b>      | <b>4,465</b>      | <b>6,015</b>      |

Table 35 - Renewal Expenditure



Photo 21 - 33kV line renewal

## 7. Risk Management

### 7.1 MLL Risk Introduction

Risks can be highly variable in their nature and scale – the conveyance of electricity (Marlborough Lines Limited’s core function) involves significant health and safety risks, but MLL is also exposed to considerable business related and other forms of risk.. To ensure that risks are managed and exposure remains within acceptable levels, MLL has adopted the systemic approach to risk management through the following Australian/New Zealand standards ISO 31000:2009 *Risk Management* and NZS 7901:2014 *Electricity and gas industries – Safety management systems for public safety*.

**Error! Reference source not found.** below shows the risk management process suggested by

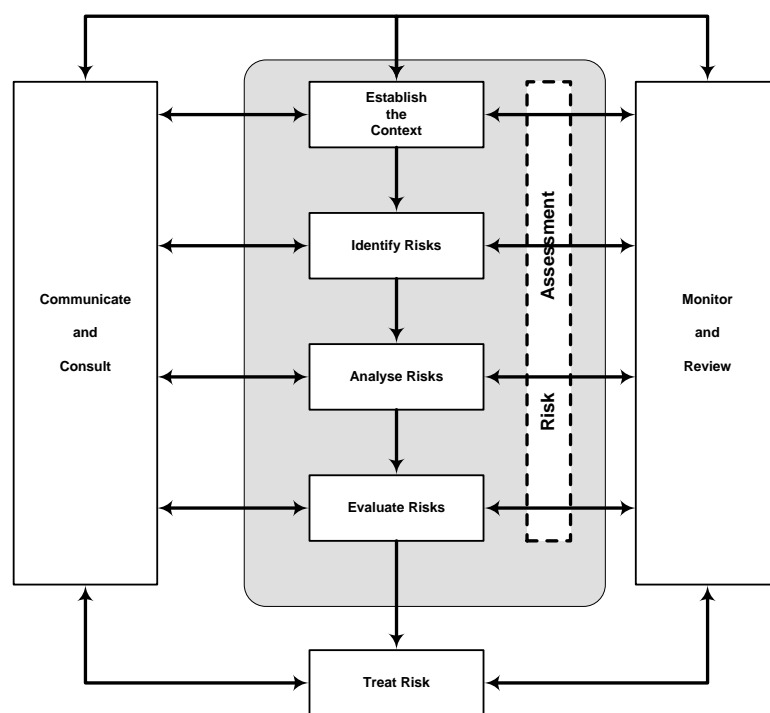

SO 31000:

Figure 22 – Risk Management Process Overview

This process has five key steps:

1. Establish the risk context
2. Risk identification
3. Risk analysis
4. Risk evaluation
5. Risk treatment

These are supported by a framework for:

- Risk monitoring and review, and
- Communication and consultation with stakeholders.

The above process allows for the effective management of all risk types affecting MLL. The definition of risk based on ISO 31000 is the effect of uncertainty on objectives. So when considering risk and risk management at MLL, it is important to understand the organisations objectives.

## **7.2 Risk Context**

The management of Network-related risks is ultimately the responsibility of the Directorate which sets the Companies strategy for effective risk management. The risk management strategy is implemented through MLL's policies and procedures which are managed by key staff including the Engineering Manager and Network Operations Manager, with oversight provided by MLL's Managing Director.

The MLL risk management process considers all credible electricity conveyance risks associated with the MLL Network including Network operational and safety risks as well as Network-related risks to the business, the environment and the general public. These are broadly grouped into the following risk category types:

- Electricity network risks
- Environmental risks
- Electricity business risks
- Regulatory compliance risks

Table 36 below provides further definition.

| <b>Risk Category Type</b>          | <b>Definition</b>  |
|------------------------------------|--|
| <b>Electricity Network Risks</b>   | Risks associated with all aspects of electricity Network construction, operation and maintenance, including health and safety risk to staff and the public, electricity supply, Network access, operational control and vegetation management.   |
| <b>Environmental Risks</b>         | Risks associated with the natural environment's potential impact on MLL's distribution Network and MLL's potential impact on the environment.  |
| <b>Electricity Business Risks</b>  | Network-related risks, including financial, which can adversely impact on MLL future viability and profitability e.g. the Commerce Commissions' threshold regulatory regime, disruptive technologies, reputation, data and knowledge management. |
| <b>Regulatory Compliance Risks</b> | Risks associated with all statutory requirements compliance, including complaints, health and safety issues, land access issues and Resource Management Act issues.  |

**Table 36 – Risk Category Types**

The range of credible risks to the MLL electricity Network is very broad and ranges from vermin damage and minor vandalism to major natural disasters such as a severe storm event(s), earthquake(s) or flooding. Similarly, the impact of these possible events can vary significantly. For example, a car versus pole incident on a lightly populated rural feeder has far less impact (and therefore loss/risk) than the same incident would at a pole carrying multiple subtransmission circuits

The distributed nature of MLL's asset base means that individual assets are less susceptible to any one event – unless of course that event is region wide. Conversely, however, as the assets are dispersed over a large number of sites, the likelihood that a portion of the assets will be affected by any one event is increased. Maintenance costs are also comparably higher due to the dispersed nature of MLL's asset base.

Marlborough Lines Limited has carefully evaluated the impact of various categories of risk and is confident that other than under an extreme event, such as a widespread severe earthquake, it has the capacity to deal with the impacts of such risks from engineering, operational, financial and environmental perspectives. The company has developed an Emergency Preparedness Plan and this is regarded as a dynamic document which is reviewed by senior staff at least annually.

Naturally the key factor in dealing with any risk is to seek avoidance through prior identification and through a range of treatment methodologies. MLL undertakes (not less than) annual reviews to assess current risks and risk management. This review process includes taking account of lessons learned by others (such as assessing the effects of a major event(s) like the Christchurch Earthquake Sequence) as well as from events that we have experienced locally (for example the 2013 Seddon earthquakes). Any lessons learned from

these experiences are incorporated into modifying and updating MLL’s risk management plan as and where appropriate.

### 7.3 Risk Management Tools

A major revision of MLL risks was completed during the 2010/2011 planning year. This involved key staff at MLL discussing the existing risk register to determine any modifications required. Although few risk additions or deletions were made, many risk ratings increased or decreased as a result of thorough discussion during the exercise. A number of clarifications to risk descriptions were also made. It is now procedural that this risk register is reviewed annually and after any major relevant events.

#### 7.3.1 Central Risk Register

This centralised operational risk register has proved to be a very effective tool for the identification, analysis, evaluation, treatment and communication of risk. It also provides a means for ongoing monitoring and review of risks. It has provided a standardised framework (compliant with ISO 31000) and has meant that MLL’s multiple risk memos and hazard registers have been superseded.

ISO 31000 suggests five levels of likelihood and consequence for risk analysis. MLL, however, has chosen to go to nine levels as this provides a far greater level of granularity. The five level analyses also have a tendency to allocate risks to higher levels as the gradation scale is coarse.

#### 7.3.2 Risk Categories

The risk categories from the 2010-2011 planning year were retained in the risk register which has been carried through to this plan. They are presented in Table 37 below.

| Risk Category         | Risk Category Type | Description  |
|-----------------------|--------------------|--|
| Regulatory breach     | Business           | A Commerce Commission threshold regime breach, leading to investigation and possible targeted control of MLL (price setting).    |
| Data management       | Business           | Issues relating to the availability and accuracy of MLL Network data (assets and asset performance / condition).                 |
| Disruptive technology | Business           | The impact of disruptive technologies on the MLL asset base and business value (i.e. technical obsolescence and Network bypass). |
| Fire damage           | Business           | Damage to MLL buildings and equipment caused by fire (Network and support infrastructure).                                       |
| Knowledge management  | Business           | Knowledge management issues (e.g. skill gaps) relating to the MLL asset base.  |
| Vandalism             | Business           | Disruption to the operation of MLL electricity distribution Network through acts of vandalism and public nuisance.               |
| Access and Control    | Electricity        | The inability of the MLL distribution Network to safely convey electricity within the supply regulations, due                    |

| Risk Category                   | Risk Category Type      | Description  |
|---------------------------------|-------------------------|--|
|                                 |                         | to the breakdown of the MLL Network access and control systems i.e. unlawful or unsafe Network connection.   |
| Distribution failure            | Electricity             | The inability of the MLL distribution Network assets to safely convey electricity within the supply regulations.   |
| Generation fail                 | Electricity             | Major generation failure causing the unavailability of electricity, within the supply regulations, to the Marlborough region.  |
| Transpower fail                 | Electricity             | The inability of the Transpower transmission Network assets to safely convey electricity within the supply regulations.  |
| Vegetation control              | Electricity             | Vegetation impacting on live lines can result in serious outages or environmental damage (i.e. fire). Constant effort is required to keep trees clear from the MLL overhead distribution assets and tracks clear so that assets can be accessed in the Marlborough Sounds. |
| MLL causes Environmental Impact | Environment             | Major natural environment impact caused by MLL distribution assets i.e. fallen lines cause a fire or an oil spill pollutes a waterway.   |
| Environment impact on MLL       | Environment             | Major natural environment impact on MLL distribution assets causing the unavailability of electricity supply to part, or all, of the Marlborough region.   |
| Complaints and/or disputes      | Regulatory and business | Complaints and/or disputes resulting in reputational damage to MLL.  |
| Health and Safety issue         | Regulatory              | Situations or events in relation to the MLL electricity distribution Network which lead to health and safety issues for MLL staff and the general public.  |
| Land access                     | Regulatory              | MLL is unable to access land to site its equipment or get access across to service / upgrade existing assets.  |
| RMA issues                      | Regulatory              | MLL is unable to progress Network expansion / maintenance or upgrade project due to RMA related issues.  |

Table 37 - Risk Categories

### 7.3.3 Risk Register

At the date of this plan a total of 85 key Network-related risks are documented in the MLL risk register. All of these risks were found to have treatments in place. Most treatments had multiple effects (i.e. staff training, emergency spares, ISO system procedures) with the effectiveness of these varying with the nature of the risk they were applied to. The division of these 85 risks across the four risk category types is presented in Table 38 below. Predictably, the majority of the identified risks relate to the distribution of electricity across the MLL Network.

| Risk Category Type        | Number of Risks |
|---------------------------|-----------------|
| Electricity network risks | 56              |

| Risk Category Type          | Number of Risks |
|-----------------------------|-----------------|
| Environmental risks         | 8               |
| Electricity business risks  | 15              |
| Regulatory compliance risks | 6               |

**Table 38 - Risk Division Across Types**

A list showing the complete risk register is included in Appendix A with the highest ranked risks set out in section 7.3.6.

### **7.3.4 Risk Treatments and Initiatives**

A risk’s likelihood and/or consequence of occurring are generally reduced through the application of risk treatments that may either avoid, transfer, reduce, remove or modify (or in rare instances, accept) the likelihood and/or consequence of risk(s).

MLL actively implements risk treatment through a number of forms. An example of risk removal is through network re-design to underground a section of line vulnerable to vehicle damage. A risk modification example is asset inspections to identify incipient material failures and therefore reduce the likelihood of the asset progressing to failure, or, having mobile generation to reduce the customer impact and therefore consequence of a network failure.



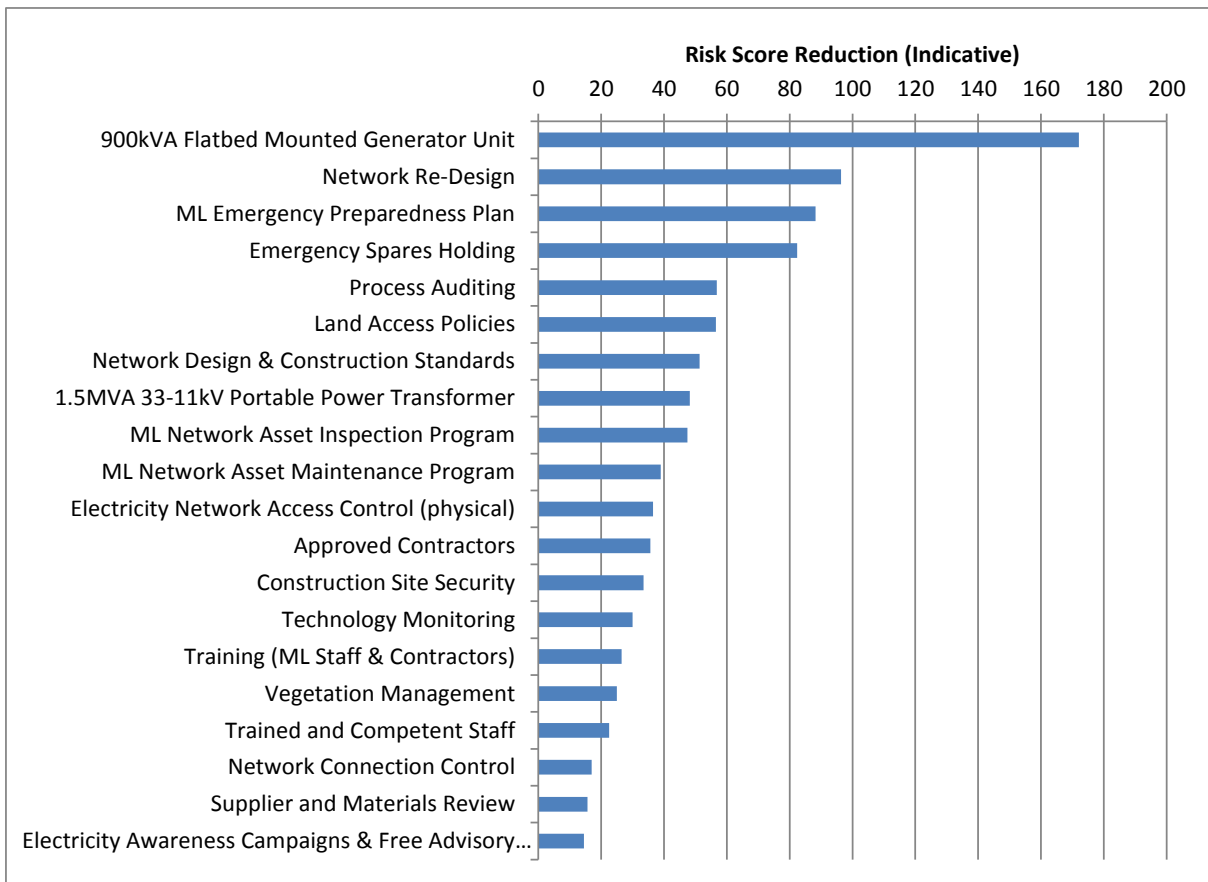

Figure 23 – Summary of risk score reduction

The chart of Figure 24 provides an indicative measure of the value returned by the risk treatments undertaken by MLL through allocating the assessed risk score reductions resulting from the application of the various risk treatments. As shown, the provision of mobile generation achieves the highest risk reduction as it finds application in mitigating a number of the supply related risks. Asset management processes such as asset inspection, critical spares management and process auditing also rank highly in this assessment underscoring the importance of these business-as-usual processes in modifying the potential likelihood and/or consequence of risk.

Initiatives through the introduction of new risk treatments and the enhancement of existing processes generally look to address the highest ranked risks or where the treatment bears improvement across a large number of the lesser risks. Initiatives set down for this asset management plan are set out in Table 39.

Table 39 presents a summary of current risk treatments implemented by MLL (note that this is a summary of the key treatments and is not an exhaustive list; other treatments may be in place that are not listed)

| Control Name  | Description   |
|---|---|
| Vehicle Training  | Vehicle training for staff in four-wheel-drive terrain  |
| Contractor Auditing                                     | Random audit visits at external contractor construction sites to investigate site safety and the level of workmanship   |
| 1.5MVA 33-11kV Portable Power Transformer               | This power transformer has been refurbished and can be installed as a portable package to allow rapid recovery in the event of a transformer failure, particularly for the smaller single transformer zone subs i.e. Ward and Rai Valley.         |
| 900kVA Flatbed Mounted Generator Unit                   | This flatbed mounted genset can be installed as a portable package to allow rapid recovery in the event of distribution asset failure.  |
| Accept Risk   | Overall risk rating means the appropriate action for ML is to accept the risk   |
| Approved Contractors                                    | The exclusive use of approved contractors on MLL's network as well as ISO system defined procedures for network access and operation.   |
| Close Approach Permit Issue & High Load Escorting       | ML: has a process (free to individuals) for handling the issue of close approach permits and assessment of the need for high load escorting. This ensures that access to expert electrical advice for the general public.                         |
| Construction Site Security                              | The securing of expensive or hard to source construction items so that they are either unavailable or not easily accessed.  |
| Electricity Awareness Campaigns & Free Advisory Service | MLL runs numerous electricity awareness campaigns and has a free electricity advisory service to heighten awareness of the efficient use but also potential dangers of electricity.   |
| Electricity Network Access Control (physical)           | Access to MLL electricity network assets is restricted to authorised (trained) personnel through the use of design, preventive barriers, keys, tooled fittings and monitored security systems. The intention is to prevent accidental access.     |
| Emergency Spares Holding                                | Emergency network spares held to ensure that adequate stocks are on-hand for corrective maintenance   |
| Incident Reporting & Investigation                      | MLL has an ISO procedure for incident reporting and investigation, which allows the timely investigation of ML network incidents and accidents so that the key issues are understood, allowing remedial action to be undertaken.                  |
| ISO System With Defined Procedures                      | Well designed, auditable systems representing best practice, leading to customer satisfaction, loss minimisation and productive efficiency.   |
| Land Access Policies                                    | MLL has ISO system procedures for securing the right to occupy space on private property.   |
| Load Control  | The use of MLL load control plant to reduce (control) load, for demand target management in normal operation as well as during periods of supply shortage.  |
| ML Emergency Preparedness Plan                          | This plan provides documentation, key contacts and background information that would be useful in a range of emergency situations. Its aim is to limit damages and speed the recovery of the MLL electricity network from an emergency situation. |

| Control Name                            | Description  |
|---|--|
| ML Network Asset Inspection Program     | MLL has processes and business systems in place to manage the identification of defective electricity network assets i.e. zone sub monthly inspections, MDI readings, earth testing, OH & UG asset inspection, etc.  |
| ML Network Asset Maintenance Program    | MLL has processes and business systems in place to manage the identification of defective electricity network assets i.e. zone sub monthly inspections, MDI readings, earth testing, OH & UG asset inspection, etc.  |
| Network Design & Construction Standards | The development and use of the MLL design and construction manuals to ensure that the ML electricity network is engineered to the highest appropriate standard. This also extends to the locating of equipment i.e. not in floodway or on known fault line, etc. |
| Network Re-Design                       | This involves the re-design of any aspect of the MLL electricity supply network, it includes network layout /configuration as well as equipment and construction standard re-design.   |
| Oil Spill kits and Site Bunding         | To minimise the potential for an environmental issue oil spill kits and bunding arrangements are installed as appropriate. Procedures and training for their use are in place.   |
| Process Auditing                        | Internal and external auditing of MLL's business systems, policies and procedures  |
| Regulatory Environment Monitoring       | Scanning of the regulatory environment in which ML is operating to look for issues / changes which will impact on the operations of MLL  |
| Resource Management Act Mitigations     | Resource Management Act issues are mitigated against in three ways; 1. a good working relationship with the Marlborough District Council, 2. defined procedures, 3. trained staff (aware of the district plan and RMA issues generally).                         |
| Site Access Control                     | MLL has procedures to ensure that visitors to sites are aware of the hazards that exist and have the appropriate PPE. Physical barriers and signage are used to keep the general public clear of such sites.   |
| Supplier and Materials Review           | MLL has ISO system procedures for supplier and materials review to ensure that the electricity network is constructed and maintained to the highest appropriate level.   |
| System or Procedure Re-Design           | This involves the re-design of any system or procedure affecting the MLL electricity supply network, it includes everything from ISO system polices to business processes to work site instructions.   |
| Technology Monitoring                   | This involves the monitoring of innovative technology development as well as its analysis to assess its potential impact on the MLL electricity distribution network   |
| Trained and Competent Staff             | MLL staff are required to become qualified in their own right (as appropriate for their role) and undergo regular / ongoing competency assessment.   |
| Training (ML Staff & Contractors)       | The delivery of training to MLL staff and contractors to reduce the likelihood and or consequences of a risk   |
| Use of Best Practice Industry           | Training materials to reduce the likelihood and or consequences  |

| Control Name               | Description   |
|----------------------------|---|
| Guidelines & Manuals       | of a risk.  |
| Vegetation Management      | The MLL vegetation management team, co-ordinate the activities of MLL staff, MLL contractors and private individuals in accord with the Electricity (Hazards from Trees) regulations 2003.  |
| Network Connection Control | The development and use of the MLL network connection control systems to ensure that the MLL electricity network is engineered to the highest appropriate engineering and safety standards. |
| Insurance                  | Insurance to cover risks such as fire damage or professional indemnity, etc.  |
| Staff succession planning  | Assessment of staff age brackets, resourcing needs and forward planning.  |

Table 39 - Risk Treatments implemented by MLL

### 7.3.5 Treated Risk Matrix

Once the identified risks were entered into the register they are grouped into a risk matrix to allow further, more detailed assessment of MLL's risk exposure and this is presented in Figure 24 below.

| Likelihood        | Insignificant | Very low | Minor | Some | Moderate | Considerable | Major | Severe | Catastrophic |
|-------------------|---------------|----------|-------|------|----------|--------------|-------|--------|--------------|
| Almost certain    | 0             | 0        | 0     | 0    | 0        | 0            | 0     | 0      | 0            |
| Very Likely       | 0             | 0        | 0     | 0    | 0        | 0            | 0     | 0      | 0            |
| Likely            | 0             | 1        | 0     | 0    | 0        | 0            | 0     | 0      | 0            |
| Very possible     | 2             | 0        | 0     | 0    | 0        | 0            | 0     | 0      | 0            |
| Possible          | 0             | 1        | 0     | 0    | 3        | 1            | 0     | 0      | 0            |
| Somewhat possible | 1             | 2        | 2     | 2    | 0        | 1            | 1     | 1      | 0            |
| Unlikely          | 1             | 5        | 3     | 16   | 1        | 0            | 0     | 0      | 0            |
| Very unlikely     | 2             | 3        | 9     | 6    | 4        | 1            | 0     | 0      | 0            |
| Rare              | 2             | 5        | 5     | 2    | 2        | 0            | 0     | 0      | 0            |

Figure 24 - Count of post-treatment risks

The highest ranked post-treatment risks fall under the category "Moderate" (having a risk score between 24 and 33). The four highest ranked risks relate to either failures at the single Transpower GXP or failures of Retailer generation, which are risks that MLL has limited capacity to mitigate. The highest risk fully within MLL's span of control is failure of single structures carrying multiple 33 kV subtransmission circuits for which MLL has specific contingency plans. Major natural disaster events such as earthquake and floods also list within the highest ranked risks.

Where possible, it is attempted to design identified Network risks out of the system, and mitigate or eliminate other risks through Network capital investment or changes to asset maintenance or work practices. Non-asset based solutions are also considered in these evaluations such as staff training and business system development.

However, it is not always possible or even feasible to eliminate risk altogether. Aside from natural disaster preparation (including considered placement of equipment and contingency plans), MLL also faces supply risk due to the nature

of electricity and its position in the supply chain. For example, the risk of non-supply through the complete or partial unavailability of generation or transmission assets has an immediate effect on MLL's operations but is a risk beyond its direct control.

### 7.3.6 Highest Rated Risks

The ten highest assessed risks, following treatment(s), are presented in Table 40 below.

| Risk Name   | Description   | Rank | Rating   | Pre-treatment Rating |
|---|---|------|----------|----------------------|
| Full Supply Outage - Transpower Transmission Network Failure  | The inability of the Transpower transmission network assets to safely convey electricity within the supply regulations, through the loss of key equipment at the Blenheim GXP or multiple transmission line failures. | 1    | Moderate | Considerable         |
| Full Supply Outage - Retailer Major Generation Failure        | Major generation failure causing the unavailability of electricity within the supply regulations to the Marlborough region.   | 2    | Moderate | High                 |
| Partial Supply Only - Transpower Transmission Network Failure | The inability of the Transpower transmission network assets to safely convey electricity within the supply regulations, due to the loss of transmission assets i.e. a supply constraint (above the Blenheim GXP).     | 3    | Moderate | Moderate             |
| Partial Supply Only - Retailer Major Generation Failure       | Major generation failure causing diminished supply availability of electricity (within the supply regulations) to the Marlborough region.   | 4    | Moderate | Considerable         |
| Multiple 33kV circuits on single structure                    | Waihopai and Redwoodtown feeders along Murphy's Road  | 4    | Moderate | Moderate             |
| Major Earthquake Damage to MLL Distribution Assets            | Major natural environment impact on MLL distribution assets causing the unavailability of electricity supply to part or the entire Marlborough region.  | 4    | Moderate | Considerable         |
| Price Path Threshold Regime Breach                            | Price Path threshold regime breach, leading to investigation and possible targeted control of MLL (price setting)   | 7    | Moderate | Considerable         |
| MLL Staff Injury / Incident                                   | A network incident or personnel injury, due to the breakdown of the MLL network access and control systems.   | 8    | Some     | Considerable         |
| Quality Threshold Regime Breach                               | Quality threshold regime breach, leading to investigation and possible targeted control of MLL (price setting)  | 8    | Some     | Considerable         |

| Risk Name                  | Description   | Rank | Rating | Pre-treatment Rating |
|----------------------------|---|------|--------|----------------------|
| 33kV Overhead Line Failure | The inability of the MLL distribution network assets to safely convey electricity within the supply regulations. Highest risk - high wind speed activity or snow loading. | 10   | Some   | Moderate             |

Table 40 - Highest Risks

### 7.3.7 General Risk Commentary

From the risk study analysis presented in Table 40 the following conclusions are drawn:

1. The overall post-treatment risk profile of MLL is presently constrained to acceptable levels.
2. The annual review of the risk register and its associated treatments will allow ongoing monitoring of this profile.
3. MLL faces a broad range of Network- related risks, but the technical expertise and operational experience of MLL has allowed the development of an equally broad range of effective treatments.
4. The most significant risks identified are in many cases inherent to the industry. There are many treatments already in place for these risks and more treatments are investigated and implemented as the business develops.
5. MLL's 33kV lines and zone substations carry some operational risk, but these are minimised by the diversity of the loads and the security offered by the existing configuration. At the time of this plan, all but one zone substation (rural), has 'n-1' transformer security. As the 11kV Network is rebuilt and upgraded, the configurations available for interconnecting other substations to live part of a failed substation 11kV Network will be increased.
6. Double 33kV circuits on common poles are another source of risk, particularly on lengths of the circuits supplying the Spring Creek and Picton zone substations. A single motor vehicle accident in these areas could result in multiple zone substations losing supply. Customers in the immediate vicinity of any such vehicle accident could have supply interrupted for the duration of the time required to repair the damage. However, alternative supply routes available within MLL's 33kV and 11kV Networks would allow supply to be restored to all other customers by manual switching to alternative feeds. Contingency plans to recover from loss of these critical structures is also in place.
7. Earthquake: A programme of assessing critical structures for their compliance with relevant current structural design codes is continuing. Structures that are assessed as having unacceptable risk will be structurally strengthened to reduce the risk of failure.
8. Generally, the MLL Network is well constructed and maintained, with ongoing asset inspection and testing regimes in place. Monitoring of these systems

and routine Network operation has not identified any significant untreated risks.

## 7.4 High impact, low probability events

Whilst of low probability, events of high consequence form a special group of risks generally dealt with through the Emergency Preparedness Plan. These risks are summarised in Table 40.

| Description   | Treatment  | Notes  |
|---|--|--|
| Earthquake resulting in major damage to Network   | Emergency Response Plans                                 | Network is predominately overhead and is therefore relatively resilient, and quick to repair once access can be obtained.  |
|   | Seismic strengthening                                    | Where appropriate, strengthening structures (such as key buildings and zone substations) to improve resilience to events   |
| Weather event resulting in major damage to Network                                      | Emergency Response Plans                                 | Network has proven resilient to flood damage, widespread wind damage, repairs generally quick: use of contractors and staff from other unaffected regions of NZ key part of solution.                |
| Loss of Grid Exit Point due to aircraft accident or deliberate destruction              | Rebuild temporary 110/33kV sub site                      | GXP is resilient against equipment failure and/or fire, with three transformers and two switch-rooms. MLL's Network configuration allows a temporary GXP to be established at alternative locations. |
| Loss of Transmission capacity   | Use of generators to keep emergency services operational | No real alternatives. Transpower Network is vulnerable to damage in the Rainbow area and Hira Forests.   |
| Forest fire resulting in loss of both 33kV lines to Picton for extended period of time. | Use of generators to provide supply                      | Generator connection points are installed but generators could only provide limited supply for limited hours.  |
| Tsunami damage to Network   | Emergency Response Plans                                 | The parts of the Network at risk from tsunami have been identified and consideration given to dealing with effects of tsunami.   |

Table 41 - High Impact Low Probability Risks

The most significant high impact, low probability event is a major earthquake causing widespread damage. Earthquakes are difficult to predict and severe damage is considered to be a very low probability, hence the inclusion of this in the high impact, low probability events.

In any earthquake scenario the most significant damage (and most expensive to repair) is likely to be to underground cables. MLL has relatively few kilometres of underground cables

and can cope with widespread damage by undertaking repairs, installing temporary overhead or new underground cables relatively quickly.

Overhead lines have proven to be relatively resilient to even quite strong earthquakes and can be repaired relatively easily.

The final areas of vulnerability associated with a major earthquake are the zone (33/11kV) substations. Currently the buildings are insured but the plant is not. It is possible that a major earthquake event could damage multiple zone substations. If this occurs the duration of the recovery process is less likely to be limited by funding than by the provision of spare transformers, switchgear and the time and resources necessary to reconstruct the sites or establish temporary new sites. In the case of the Christchurch Earthquake Sequence, although a number of the Christchurch substations experienced liquefaction, actual damage to transformers and switchgear was slight. Upon review this has largely been put down to seismic strengthening works that were undertaken on substations prior to the Christchurch Earthquake Sequence.

Figures showing the likely liquefaction zones and tsunami zones for Marlborough are included in Appendix F.

## 7.5 Emergency response plans

MLL's Emergency Preparedness Plan documents procedures for use in the event of major damage to the Network. It contains information on Transpower, the 33kV system, the zone substations, the 11kV lines, supplier's contact details, staff, customers and other information which may be useful at times of emergency. Contingency planning is regularly reviewed with consideration given to various "what-if" scenarios. This helps to ensure that the Network is prepared and that staff are well trained for any eventuality.

MLL operates a 24/7 fault service, with sufficient staff levels to ensure appropriate responses to any foreseeable event on the Network.

MLL is involved in Civil Defence and emergency management activities in conjunction with the Marlborough District Council and other key community groups. Liaison is, in the first instance, through the emergency services groups of each organisation. Regular meetings between MLL and the other groups are held to review and assess current plans.

Civil Defence involvement is not restricted to natural disasters, but includes any event – planned or unplanned – which disrupts the Marlborough area and may limit MLL's capability to respond. For example a large festival may place a high peak load on local infrastructure for a short duration.

Following on from the Christchurch Earthquake Sequence, MLL has reviewed the Emergency preparedness plan and the location of the control room. An emergency control room is available at our Springlands site, and could be quickly setup at the Taylor Pass site. An emergency repeater has been purchased to allow communications to be quickly re-established in the event of loss of existing systems.

MLL is part of a group of South Island lines companies that have agreed to a Mutual Aid Cooperative in the event of major disruption to individual or multiple Networks. MLL sent staff and diesel generators to Kaiapoi and Christchurch following the Christchurch Earthquake Sequence.



## 8. Risk Register

| Risk Name  | Risk Category                                 | Type  | Risk Description  | Rating   | Pre-treatment Rating |
|--|---|-------|---|----------|----------------------|
| Full Supply Outage<br>- Transpower<br>Transmission<br>Network Failure  | Transpower<br>Transmission<br>Network Failure | Elect | The inability of the Transpower transmission network assets to safely convey electricity within the supply regulations, through the loss of key equipment at the Blenheim GXP or multiple transmission line failures. | Moderate | Considerable         |
| Full Supply Outage<br>- Retailer Major<br>Generation Failure           | Retailer Major<br>Generation Failure          | Elect | Major generation failure causing the unavailability of electricity within the supply regulations to the Marlborough region.   | Moderate | High                 |
| Partial Supply Only<br>- Transpower<br>Transmission<br>Network Failure | Transpower<br>Transmission<br>Network Failure | Elect | The inability of the Transpower transmission network assets to safely convey electricity within the supply regulations, due to the loss of transmission assets i.e. a supply constraint (above the Blenheim GXP).     | Moderate | Moderate             |
| Partial Supply Only<br>- Retailer Major<br>Generation Failure          | Retailer Major<br>Generation Failure          | Elect | Major generation failure causing diminished supply availability of electricity (within the supply regulations) to the Marlborough region.   | Moderate | Considerable         |
| Multiple 33kV<br>circuits on single<br>structure                       | MLL Distribution<br>Network Failure           | Elect | Waihopai and Redwoodtown feeders along Murphys Road   | Moderate | Moderate             |

| Risk Name  | Risk Category   | Type  | Risk Description  | Rating   | Pre-treatment Rating |
|--|---|-------|---|----------|----------------------|
| Major Earthquake Damage to MLL Distribution Assets | Natural Environment Impact on MLL Distribution Assets | Env   | Major natural environment impact on MLL distribution assets causing the unavailability of electricity supply to part or all of the Marlborough region.                    | Moderate | Considerable         |
| Price Path Threshold Regime Breach                 | Commerce Commission Threshold Regime Breach           | Bus   | Price Path threshold regime breach, leading to investigation and possible targeted control of MLL (price setting)   | Moderate | Considerable         |
| MLL Staff Injury / Incident                        | MLL Distribution Network Access and Control Breakdown | Bus   | A network incident or personnel injury, due to the breakdown of the MLL network access and control systems.   | Some     | Considerable         |
| Quality Threshold Regime Breach                    | Commerce Commission Threshold Regime Breach           | Bus   | Quality threshold regime breach, leading to investigation and possible targeted control of MLL (price setting)  | Some     | Considerable         |
| 33kV Overhead Line Failure                         | MLL Distribution Network Failure                      | Elect | The inability of the MLL distribution network assets to safely convey electricity within the supply regulations. Highest risk - high wind speed activity or snow loading. | Some     | Moderate             |

| Risk Name   | Risk Category   | Type  | Risk Description   | Rating | Pre-treatment Rating |
|---|---|-------|--|--------|----------------------|
| Lightning Storm Damage to MLL Distribution Assets | Natural Environment Impact on MLL Distribution Assets | Env   | A lightning storm resulting in damage to MLL distribution assets causing the unavailability of electricity supply to part or all of the Marlborough region.            | Low    | Moderate             |
| Contractor Injury / Incident                      | MLL Distribution Network Access and Control Breakdown | Bus   | A contractor incident or personnel injury, due to the breakdown of the MLL network access and control systems.   | Low    | Moderate             |
| Public Injury / Incident                          | MLL Distribution Network Access and Control Breakdown | Bus   | A member of the public has an incident or personnel injury, due to the breakdown of the MLL network access and control systems.  | Low    | Some                 |
| ABS & HV Fuse Failure                             | MLL Distribution Network Failure                      | Elect | The inability of the MLL distribution network assets to safely convey electricity within the supply regulations. Highest risk - lightning or high wind speed activity. | Low    | Moderate             |
| Ring Main Unit Failure                            | MLL Distribution Network Failure                      | Elect | The inability of the MLL distribution network assets to safely convey electricity within the supply regulations. Highest risk - earthquake or flood activity.          | Low    | Some                 |

| Risk Name  | Risk Category   | Type  | Risk Description  | Rating | Pre-treatment Rating |
|--|---|-------|---|--------|----------------------|
| High Winds Causing Damage to MLL Distribution Assets | Natural Environment Impact on MLL Distribution Assets | Env   | Natural environment impact on MLL distribution assets causing the unavailability of electricity supply to part or all of the Marlborough region.                                | Low    | Moderate             |
| Switching structures                                 | MLL Distribution Network Failure                      | Elect | An entire switching structure is compromised and all switching structure switches are inoperable  | Low    | Moderate             |
| Fault Security Constraint at Havelock Zone Sub       | MLL Distribution Network Failure                      | Elect | 100% of the time this sub only has a "n" fault security level, meaning any fault issues at this sub would definitely result in a network outage.                                | Low    | Some                 |
| 11kV Cable Failure                                   | MLL Distribution Network Failure                      | Elect | 11kV cable failure causing the inability of the MLL distribution network assets to safely convey electricity within the supply regulations. Highest risk - earthquake activity. | Low    | Some                 |
| 11kV Overhead Line Failure                           | MLL Distribution Network Failure                      | Elect | The inability of the MLL distribution network assets to safely convey electricity within the supply regulations. Highest risk - high wind speed activity or snow loading.       | Low    | Moderate             |

| Risk Name  | Risk Category                    | Type  | Risk Description  | Rating | Pre-treatment Rating |
|--|----------------------------------|-------|---|--------|----------------------|
| 33kV UG Cable Failure Due to 3rd Party (excavation) Damage | MLL Distribution Network Failure | Elect | 33kV UG cable failure causes the loss of supply to MLL distribution network assets and therefore the loss of a subtrans circuit or a zone substation.                           | Low    | Moderate             |
| Power TX Failure   | MLL Distribution Network Failure | Elect | The inability of the MLL distribution network assets to safely convey electricity within the supply regulations. Highest risk - earthquake activity.                            | Low    | Considerable         |
| Fault Security Constraint at Rai Valley Zone Sub           | MLL Distribution Network Failure | Elect | 100% of the time this sub only has a "n" fault security level, meaning any fault issues at this sub would definitely result in a network outage.                                | Low    | Some                 |
| 400V UG Cable Failure Due to 3rd Party (excavation) Damage | MLL Distribution Network Failure | Elect | The inability of the MLL distribution network assets to safely convey electricity within the supply regulations.  | Low    | Some                 |
| Single 33kV Supply to Linkwater Zone Sub                   | MLL Distribution Network Failure | Elect | The single 33kV supply to Linkwater zone sub means that a failure in this line or the equipment that connects it to the wider network, will result in a zone substation outage. | Low    | Some                 |

| Risk Name                                   | Risk Category   | Type  | Risk Description   | Rating | Pre-treatment Rating |
|---|---|-------|--|--------|----------------------|
| Landslide Damage to MLL Distribution Assets | Natural Environment Impact on MLL Distribution Assets | Env   | Natural environment impact on MLL distribution assets causing the unavailability of electricity supply to part or all of the Marlborough region.                                 | Low    | Some                 |
| Single 33kV Supply to Rai Valley Zone Sub   | MLL Distribution Network Failure                      | Elect | The single 33kV supply to Rai Valley zone sub means that a failure in this line or the equipment that connects it to the wider network, will result in a zone substation outage. | Low    | Some                 |
| Single 33kV Supply to Ward Zone Sub         | MLL Distribution Network Failure                      | Elect | The single 33kV supply to Ward zone sub means that a failure in this line or the equipment that connects it to the wider network, will result in a zone substation outage.       | Low    | Some                 |
| 33kV Cable Failure                          | MLL Distribution Network Failure                      | Elect | The inability of the MLL distribution network assets to safely convey electricity within the supply regulations. Highest risk - earthquake activity.                             | Low    | Moderate             |

| Risk Name  | Risk Category                    | Type  | Risk Description   | Rating   | Pre-treatment Rating |
|--|----------------------------------|-------|--|----------|----------------------|
| Single 33kV Supply to Leefield Zone Sub                    | MLL Distribution Network Failure | Elect | The single 33kV supply to Leefield zone sub means that a failure in this line or the equipment that connects it to the wider network, will result in a zone substation outage.   | Low      | Some                 |
| Vegetation Clearance from MLL Overhead Distribution Assets | Vegetation Control               | Elect | Failure to maintain clearance reduces network reliability, would breach a statutory requirement (tree regs 2003), incurs significant 'catch up' costs and may present a serious safety risk to staff & general public. | Very low | Moderate             |
| Availability of Roothing Network                           | MLL Distribution Network Failure | Elect | Analysis and past experience has revealed that restoration of power supply during civil defence emergencies is very dependant on the availability of the rooding network for access.                                   | Very low | Low                  |
| 11kV UG Cable Failure Due to 3rd Party (excavation) Damage | MLL Distribution Network Failure | Elect | 11kV UG cable failure causes the loss of supply to MLL distribution network assets and therefore the loss of an 11kV circuit or a feeder.  | Very low | Some                 |

| Risk Name                                     | Risk Category   | Type  | Risk Description  | Rating   | Pre-treatment Rating |
|---|---|-------|---|----------|----------------------|
| Indoor Switchgear Failure                     | MLL Distribution Network Failure                      | Elect | The inability of the MLL distribution network assets to safely convey electricity within the supply regulations. Highest risk - earthquake activity.                      | Very low | Moderate             |
| Transformer Oil Spill (In-Situ or in Transit) | MLL Distribution Assets Impact on Natural Environment | Env   | Major natural environment impact caused by transformer oil contaminating soil, waterways or stormwater drains, etc.   | Very low | Moderate             |
| Network Asset (or related) Site Security      | Vandalism and Public Nuisance                         | Bus   | Disruption to the operation of MLL electricity distribution network through acts of vandalism and public nuisance.  | Very low | Moderate             |
| Poor Workmanship Faults                       | MLL Distribution Network Failure                      | Elect | Poor workmanship faults resulting in the inability of the MLL distribution network assets to safely convey electricity within the supply regulations.                     | Very low | Some                 |
| 400V Overhead Line Failure                    | MLL Distribution Network Failure                      | Elect | The inability of the MLL distribution network assets to safely convey electricity within the supply regulations. Highest risk - high wind speed activity or snow loading. | Very low | Some                 |



| Risk Name  | Risk Category                    | Type  | Risk Description  | Rating   | Pre-treatment Rating |
|--|----------------------------------|-------|---|----------|----------------------|
| Land Access Difficulties                         | Land Access Difficulties         | Reg   | MLL is unable to access land to site its equipment or get access across to construct existing assets  | Very low | Moderate             |
| Multiple 33kV circuits on single structure       | MLL Distribution Network Failure | Elect | Picton 1 and 2 Feeders between O'Dwyers Road and Tuamarina, especially a pole on SH1 north of Wairau River bridge   | Very low | Some                 |
| Multiple 11kV circuits on single structure       | MLL Distribution Network Failure | Elect | Talleys and Renwick Feeders along Old Renwick Road  | Very low | Some                 |
| Pole Mounted TX Failure                          | MLL Distribution Network Failure | Elect | The inability of the MLL distribution network assets to safely convey electricity within the supply regulations. Highest risk - lightning or earthquake activity. | Very low | Some                 |
| Ground Mounted TX Failure                        | MLL Distribution Network Failure | Elect | The inability of the MLL distribution network assets to safely convey electricity within the supply regulations. Highest risk - earthquake activity or flood.     | Very low | Some                 |
| Fault Security Constraint at Riverlands Zone Sub | MLL Distribution Network Failure | Elect | 20% of the time this sub only has a "n" fault security level, meaning any fault issues at this sub during this time would definitely result in a network outage.  | Very low | Low                  |

| Risk Name  | Risk Category                    | Type  | Risk Description   | Rating        | Pre-treatment Rating |
|--|----------------------------------|-------|--|---------------|----------------------|
| Fault Security Constraint at Seddon Zone Sub         | MLL Distribution Network Failure | Elect | 10% of the time this sub only has a "n" fault security level, meaning any fault issues at this sub during this time would definitely result in a network outage.   | Very low      | Very low             |
| Maintenance Security Constraint at Havelock Zone Sub | MLL Distribution Network Failure | Elect | 35% of the time this sub only has a "n" maintenance security level, meaning any maintenance activity during these times would definitely involve a shutdown. Maintenance security achieved by 11kV tie.        | Very low      | Very low             |
| Car versus Pole or Equipment                         | MLL Distribution Network Failure | Elect | The inability of the MLL distribution network assets to safely convey electricity within the supply regulations. Highest risk - high traffic density, access constricted areas and poor network design.        | Insignificant | Moderate             |
| Access Track Clearance                               | Vegetation Control               | Elect | Constant effort is required to keep tracks clear so that assets can be accessed in the Marlborough Sounds. Failure to do so makes the network less reliable and increases network fault repair/response times. | Insignificant | Some                 |

| Risk Name                                  | Risk Category   | Type  | Risk Description  | Rating        | Pre-treatment Rating |
|--|---|-------|---|---------------|----------------------|
| Land Access Difficulties                   | Land Access Difficulties                              | Reg   | MLL is unable to access land to site its equipment or get access across to service / inspect / upgrade existing assets or vegetation.   | Insignificant | Moderate             |
| Micro Generation Interconnection           | Disruptive Technologies                               | Bus   | The impact disruptive technologies on the MLL network supply quality, voltage regulation, etc.  | Insignificant | Moderate             |
| Unlawful or Unsafe Network Connection      | MLL Distribution Network Access and Control Breakdown | Elect | The inability of the MLL distribution network to safely convey electricity within the supply regulations, due to the breakdown of the MLL network access and control systems i.e. unlawful or unsafe network connection | Insignificant | Moderate             |
| Multiple 33kV circuits on single structure | MLL Distribution Network Failure                      | Elect | Redwood Pass and Dashwood Pass lines south of Riverlands and again north of Seddon  | Insignificant | Some                 |
| Multiple 33kV circuits on single structure | MLL Distribution Network Failure                      | Elect | Two branches of Rai Valley feeder along floor of Kaituna Valley   | Insignificant | Some                 |
| Adequate Fuel Supply                       | MLL Distribution Network Failure                      | Elect | Analysis and past experience has revealed that restoration of power supply during civil defence emergencies is very dependant on the availability of adequate fuel supplies.  | Insignificant | Some                 |

| Risk Name                                  | Risk Category                      | Type  | Risk Description   | Rating        | Pre-treatment Rating |
|--|------------------------------------|-------|--|---------------|----------------------|
| Multiple 11kV circuits on single structure | MLL Distribution Network Failure   | Elect | Renwick and Kaituna feeders along Anglesea St  | Insignificant | Low                  |
| Multiple 11kV circuits on single structure | MLL Distribution Network Failure   | Elect | Waikawa and Buller Street feeders along Canterbury Street  | Insignificant | Low                  |
| Inadequate emergency stock                 | Stores                             | Elect | MLL does not have adequate stock on hand to repair faults in the network   | Insignificant | Low                  |
| Ripple signal failure                      | MLL Distribution Network Failure   | Elect | A problem at system control that causes 1 or more injection cells to fail to send a ripple signal  | Insignificant | Low                  |
| MI Asset or Equipment Obsolescence         | MI Asset or Equipment Obsolescence | Bus   | Assets or equipment owned by MLL becomes obsolete due to business requirements   | Insignificant | Some                 |
| 400V Box Failure                           | MLL Distribution Network Failure   | Elect | The inability of the MLL distribution network assets to safely convey electricity within the supply regulations. Highest risk - vehicle damage or flood.                                 | Insignificant | Some                 |
| Distributed Generation - Fuel Cells        | Disruptive Technologies            | Bus   | Disruptive technologies have the potential to lower MLL revenues and hence asset value (i.e. island networks that only need back up supply therefore line charge but no delivery charge) | Insignificant | Moderate             |

| Risk Name                                  | Risk Category                                     | Type  | Risk Description  | Rating        | Pre-treatment Rating |
|--|---|-------|---|---------------|----------------------|
| 400V Cable Failure                         | MLL Distribution Network Failure                  | Elect | The inability of the MLL distribution network assets to safely convey electricity within the supply regulations. Highest risk - earthquake activity.                          | Insignificant | Very low             |
| Communications failure                     | Communications                                    | Elect | Unavailability of MLL voice data (radio) network  | Insignificant | Very low             |
| Multiple 11kV circuits on single structure | MLL Distribution Network Failure                  | Elect | Dashwood and Seaview feeders north of Seddon, Grassmere and Richmond Brook feeders south of Seddon  | Insignificant | Low                  |
| Open point failure                         | MLL Distribution Network Failure                  | Elect | Failure of a switch at an open point between two feeders  | Insignificant | Some                 |
| Resource Management Act Issues             | Resource Management Act Issues                    | Reg   | MLL is unable to progress a network expansion project due to RMA issues.  | Insignificant | Some                 |
| Site Access Control                        | Health & Safety Issues (staff and general public) | Reg   | Situations or events in relation to the MLL electricity distribution network construction program which lead to health and safety issues for MLL staff and the general public | Insignificant | Moderate             |

| Risk Name  | Risk Category   | Type  | Risk Description  | Rating        | Pre-treatment Rating |
|--|---|-------|---|---------------|----------------------|
| Flooding Causing Damage to MLL Distribution Assets | Natural Environment Impact on MLL Distribution Assets | Env   | Natural environment impact on MLL distribution assets causing the unavailability of electricity supply to part or all of the Marlborough region.  | Insignificant | Some                 |
| Multiple 11kV circuits on single structure         | MLL Distribution Network Failure                      | Elect | Vernon and Cloudy Bay feeders around Montana  | Insignificant | Low                  |
| Communications failure                             | Communications  | Elect | Unavailability of cell phone network  | Insignificant | Very low             |
| Latent Material Defects                            | MLL Distribution Network Failure                      | Elect | Material defects resulting in the inability of the MLL distribution network to safely convey electricity within the supply regulations.           | Insignificant | Some                 |
| Lack of Maintenance Related Network Failure        | MLL Distribution Network Failure                      | Elect | The inability of the MLL distribution network assets to safely convey electricity within the supply regulations.                                  | Insignificant | Moderate             |
| Maintenance Security Constraint at Picton Zone Sub | MLL Distribution Network Failure                      | Elect | When one transformer is out of service there is only 1 33kV line supplying the substation due to the lack of a 33kV bus coupler                   | Insignificant | Very low             |
| High Load Damage to Lines and Equipment            | MLL Distribution Network Failure                      | Elect | The inability of the MLL distribution network assets to safely convey electricity within the supply regulations. Highest risk - unescorted loads. | Insignificant | Some                 |

| Risk Name                     | Risk Category   | Type | Risk Description   | Rating        | Pre-treatment Rating |
|-------------------------------|---|------|--|---------------|----------------------|
| MLL Asset Design              | MLL Distribution Assets Impact on Natural Environment | Env  | Poor design leading to a negative impact on the environment surrounding MLL substation assets i.e. control of SF6 gas, assets not blending into the environment, poor noise control. | Insignificant | Some                 |
| Electricity Complaints        | Electricity Complaints                                | Reg  | Complaints resulting in reputational damage to MLL   | Insignificant | Some                 |
| Vandalism at the Blenheim GXP | Vandalism and Public Nuisance                         | Bus  | Disruption to the operation of MLL electricity distribution network through acts of vandalism at the Blenheim GXP.   | Insignificant | Considerable         |
| Construction Site Security    | Vandalism and Public Nuisance                         | Bus  | Disruption to the operation of MLL electricity distribution network through acts of vandalism and public nuisance at network construction sites.                                     | Insignificant | Moderate             |
| Skill Gaps                    | Knowledge Management                                  | Bus  | Skill gaps relating to the MLL asset base i.e. either equipment becomes technically obsolescent (no one can maintain it) or MLL can't attract the skills it need in the marketplace. | Insignificant | Very low             |

| Risk Name                              | Risk Category   | Type  | Risk Description   | Rating        | Pre-treatment Rating |
|--|---|-------|--|---------------|----------------------|
| Fire Damage to Buildings and Equipment | Fire Damage to Buildings and Equipment                | Bus   | Damage to MLL buildings and equipment (network and support infrastructure) caused by fire.   | Insignificant | Low                  |
| Chemical Spray (use and storage)       | MLL Distribution Assets Impact on Natural Environment | Env   | Major natural environment impact caused by the use of chemical sprays i.e. overspray drift, on-site mixing polluting waterways, unsafe storage or transit (fume inhalation). | Insignificant | Moderate             |
| Resource Management Act Issues         | Resource Management Act Issues                        | Reg   | MLL is unable to progress network maintenance or upgrade work due to RMA issues.   | Insignificant | Very low             |
| Loss of Tacit Institutional Knowledge  | Knowledge Management                                  | Bus   | The loss of detailed background data (often uncodified) relating to the MLL asset base i.e. how to access equipment, likely fault locations, etc.                            | Insignificant | Some                 |
| Data Record Unavailability             | Data Management and Record Access                     | Bus   | Issues relating to the availability and accuracy of MLL network data (assets and asset performance / condition).   | Insignificant | Moderate             |
| Extended Recovery From Network Outage  | MLL Distribution Network Access and Control Breakdown | Elect | Longer than necessary outage, due to the breakdown of the MLL network access and control systems   | Insignificant | Moderate             |



| Risk Name  | Risk Category                           | Type  | Risk Description  | Rating   | Pre-treatment Rating |
|--|---|-------|---|----------|----------------------|
| Full Supply Outage - Transpower Transmission Network Failure | Transpower Transmission Network Failure | Elect | The inability of the Transpower transmission network assets to safely convey electricity within the supply regulations, through the loss of key equipment at the Blenheim GXP or multiple transmission line failures. | Moderate | Considerable         |
| Full Supply Outage - Retailer Major Generation Failure       | Retailer Major Generation Failure       | Elect | Major generation failure causing the unavailability of electricity within the supply regulations to the Marlborough region.   | Moderate | High                 |

## 9. Performance Evaluation

This section examines the comparative performance of MLL in relation to other Electricity Distribution Businesses (EDBs) operating in New Zealand and then examines the Network's achieved performance against MLL's service level targets.<sup>2</sup>

The comparative assessment shows MLL at, or better than, expectation levels compared to other EDBs with the noted exception of operational costs, which, although higher than expectation levels, are commensurate with an above average reliability performance in accordance with the service level target that has been set for this.

The comparative assessment together with the evaluation of performance against service level targets set the basis for the asset management strategies and plans set out in the remainder of this document.

### 9.1 Comparative Assessment

This section benchmarks MLL against other New Zealand distribution businesses under a variety of cost and service level criteria.

<sup>2</sup> The comparative charts in this section apply the following convention unless otherwise noted: Red dot = FY2014 year performance; All years = FY2013 to FY2014; Purple dots = all years performance other than FY2014; blue line = regression expectation; blue dotted line = 95% confidence bounds on regression line; orange dotted line = 95% confidence on regression prediction; orange squares = outlier points; green points = exempt (trust-owned) EDBs.

### 9.1.1 Operational Expenditure (Opex)

The chart of Figure 25 describes the proportions of MLL's operational costs in relation to the average of all EDBs taken together. This shows MLL's operational costs apportion much like other distribution businesses apart from a higher relative cost in vegetation management. Placing emphasis on vegetation management is a deliberate asset management policy and contributes to the better than expectation reliability performance of the Network discussed later.

The emphasis on preventive maintenance is also reflected in the lower than average 'ratio of fault to preventive maintenance' expenditure, also charted in Figure 25.

#### 9.1.1.1 Direct Opex

Direct Opex is that proportion of operational expenditure spent directly on Network assets (as opposed to expenditure operating the Network and associated business support costs). The chart of Figure 26 shows a regression of direct opex in relation to the size of the assets being serviced – expressed in terms of a combination of the total circuit length and the transformation capacity. This shows MLL's direct opex is relatively high, although still within the confidence bounds of the regression model. Of note is the high direct opex cost in FY2014 compared to FY2013 which arose from wind storms and the Seddon earthquakes occurring within that financial year.

**Average Opex Make-up  
(all EDBs, all years)**

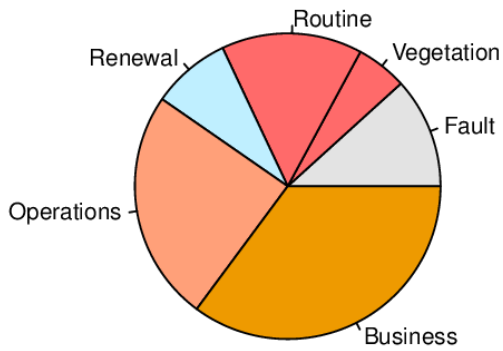

**Marlborough Lines Limited Opex  
(all years)**

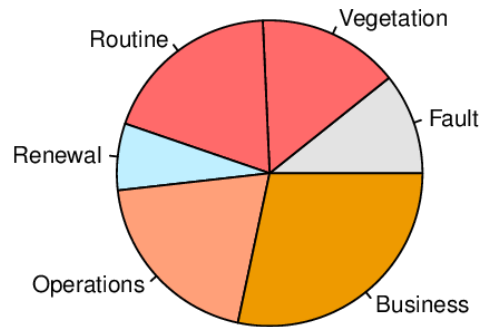

**Marlborough Lines Limited Opex  
FY 2014**

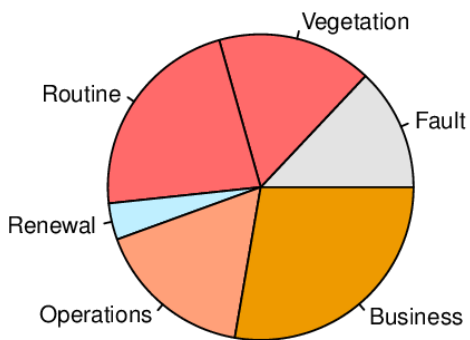

**Distribution Fault to Preventive  
(all years)**

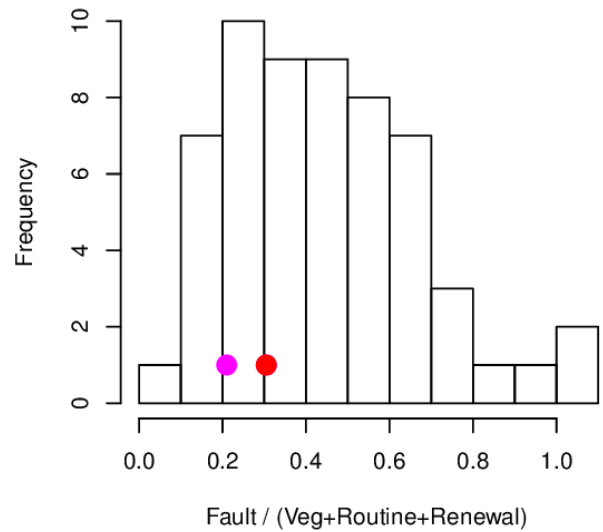

**Figure 25 - Comparison of Opex**

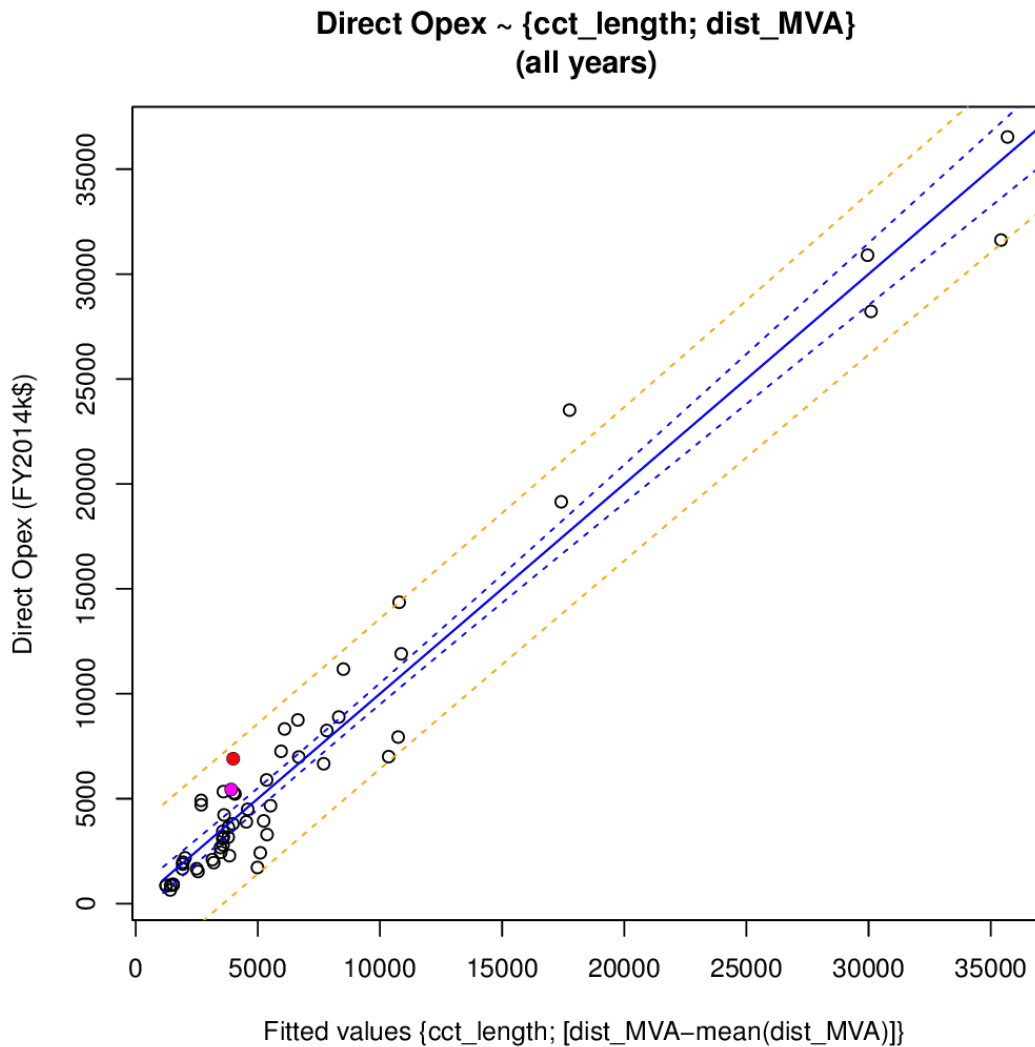

**Figure 26 - Regression for Direct Opex**

The higher than average direct operational costs again arise from the emphasis MLL places on preventive maintenance in achieving its Network reliability targets.

**9.1.1.2 Vegetation Management Costs**

As noted previously, vegetation management makes up a large part of the MLL direct costs. This is also revealed in the regression of vegetation management cost versus overhead line length, illustrated in the chart of

Figure 27, which shows higher than expectation costs compared to other distribution businesses. Closer examination shows the degree by which vegetation management costs are above the expectation line is close to that by which the direct opex is over the direct opex expectation line – that is, the vegetation management costs alone largely account for the opex variance.

As noted previously however, emphasis on vegetation control is a deliberate asset strategy to meet the reliability targets set for the

Network. As discussed later, the increased direct costs are balanced by the community value being created.

### Vegetation Opex by Overhead Length (all years)

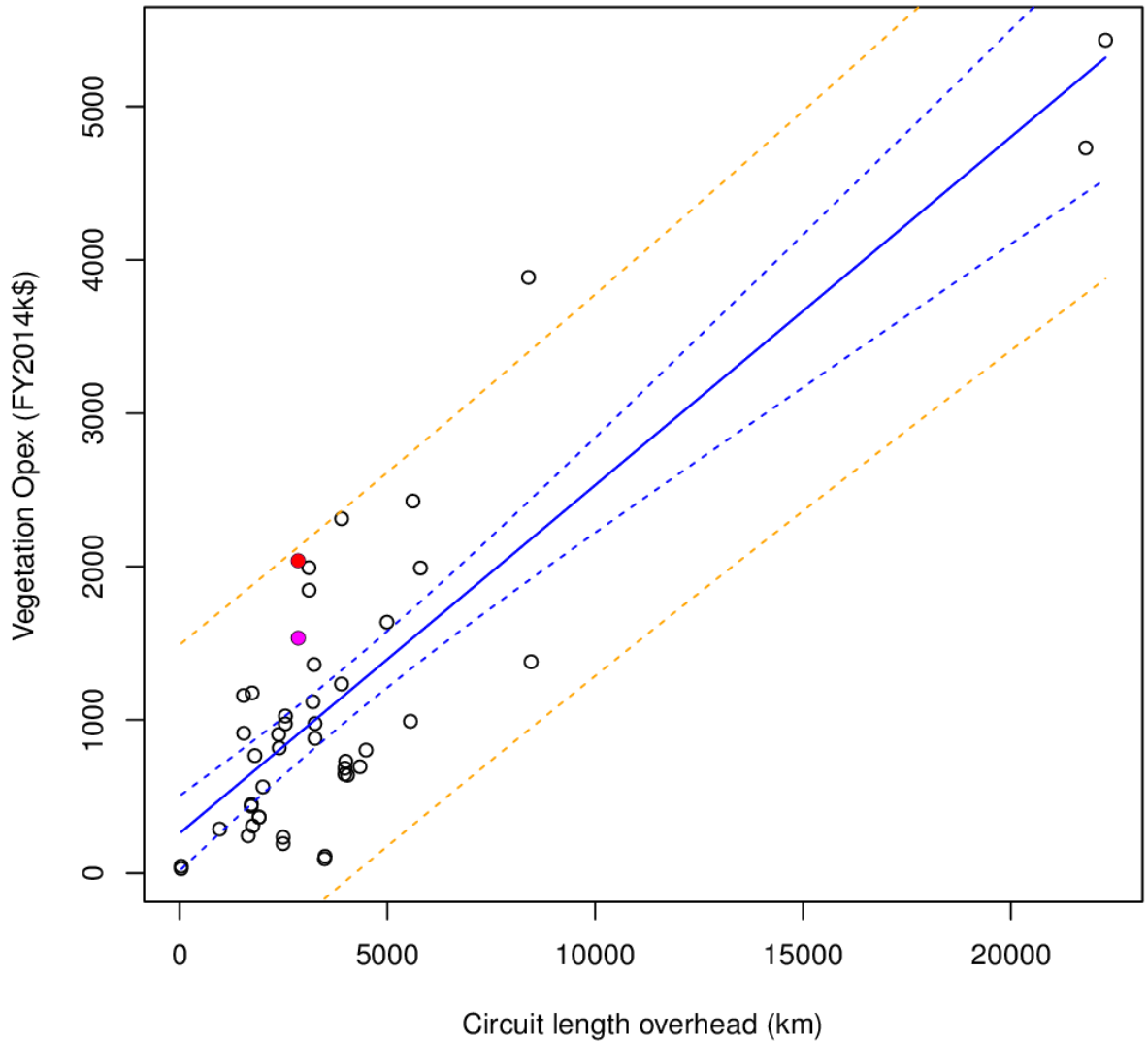

Figure 27: Regression Expectation for Vegetation Opex

#### 9.1.1.3 Indirect Opex

Indirect opex is that portion of operational expenditure accounted to the operation of the Network (i.e. switching and system control etc.) and to the business support functions associated with running a Network business. The comparative indirect opex of MLL in relation to other New Zealand distribution businesses is illustrated in Figure 28 below, where the costs are compared against the number of customers and against the regulatory value of the Network assets. Under both

measures, MLL plot close to the regression expectation indicating expenditure in this category is at appropriate levels.

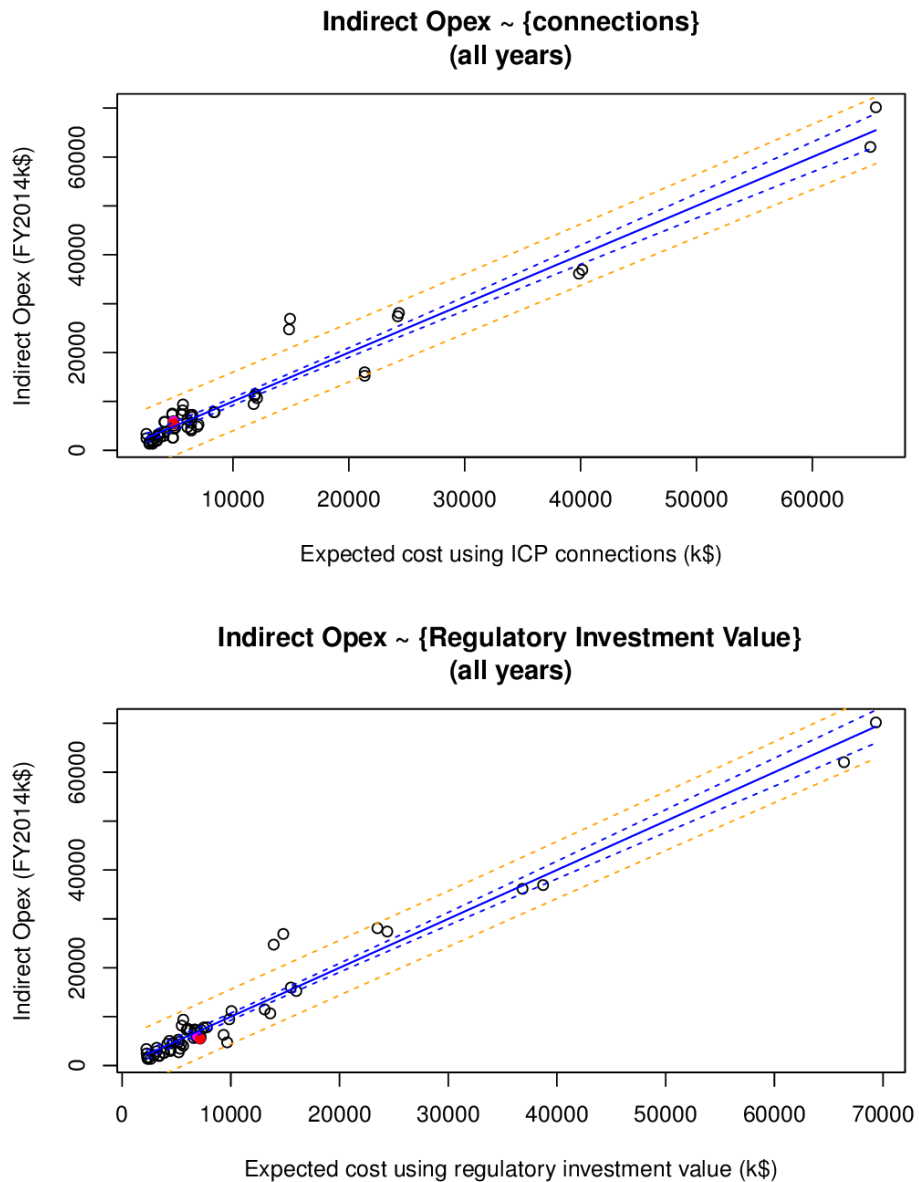

Figure 28: Expectation for Indirect Opex

### 9.1.2 Capital Expenditure (Capex)

Capex is accounted, for regulatory purposes, under five categories: connections, growth, renewal and replacement, reliability and safety, and non-network. Categories of growth, reliability and safety and non-network are not readily amendable to comparative assessment; as capital projects in these categories are highly circumstantial for each business and expenditure control relies on the capital governance processes in place –i.e. each project is supported on its own business case. Connection Capex (the cost of establishing new load connections onto the Network) is more amendable to comparative assessment as discussed next. Renewal and replacement work is also highly circumstantial but, as age is a major

driver of renewal and replacement, this category of capital expenditure may be broadly compared through modelling of the asset populations and this aspect is also discussed.

### 9.1.2.1 Connections Capex

The comparative regression for connections Capex is provided in the chart of Figure 29. A large scatter is evident arising from the significant approximations in this regression.<sup>3</sup> However, MLL plot on or below the regression line indicating, prime-facie, that MLL's costs in this category are not excessive.

### Connection Capex ~ New Connections (all years)

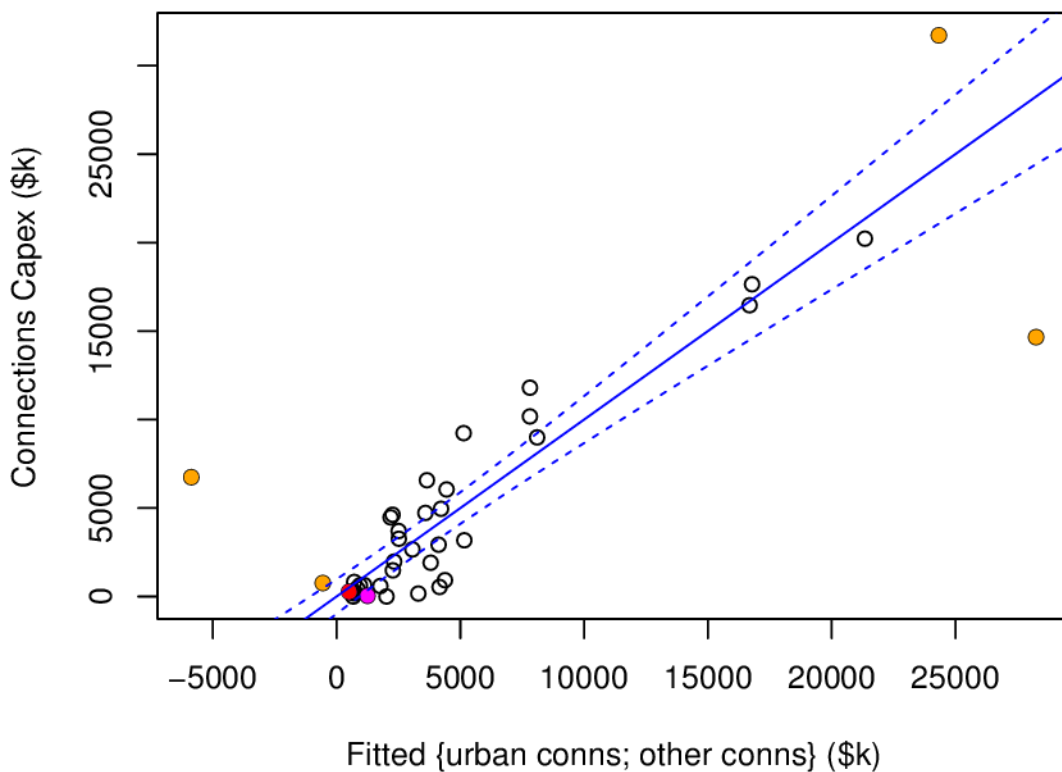

Figure 29: Expectation for Connections Capex

### 9.1.2.2 Renewal and Replacement Capex

This section is based on extracts from the Hyland McQueen Ltd comparative benchmarking review of electricity distribution businesses

<sup>3</sup> In particular that the information disclosure only identifies the change in connections numbers so is net of disconnections (hence the large negative point which is for Orion in FY2013 being a consequence of the Christchurch earthquake). Also, the apportionment of urban and rural connections in the regression relationship assumes these split as per the urban/rural line length ratio which will not be true in all cases. The accounting of capital contributions will also be a factor.

for FY2014. The model applied considered the replacement probabilities with age of Network assets under 51 categories and is calculated using the combined age profiles of asset classes over all distribution businesses in New Zealand. When applied to each business separately, the model indicates, in broad terms, the expected renewal and replacement Capex forecast of the “average” business in the circumstances of the asset numbers and asset ages of the particular business.

When applied to MLL, the model agreement is reasonable, as illustrated in Figure 30 below, indicating MLL’s forecasts for replacement expenditure is not unreasonable in comparison to what other businesses might spend in its particular circumstances. More detailed breakdown shows the main area of difference is in sub-transmission lines’ expenditure where it is known that MLL’s practice of building replacement sub-transmission lines at higher voltage rating will increase the effective replacement rate. However, MLL undertakes this form of re-construction to improve Network reliability and to build future provision for the load transfer capability of its sub-transmission circuits.

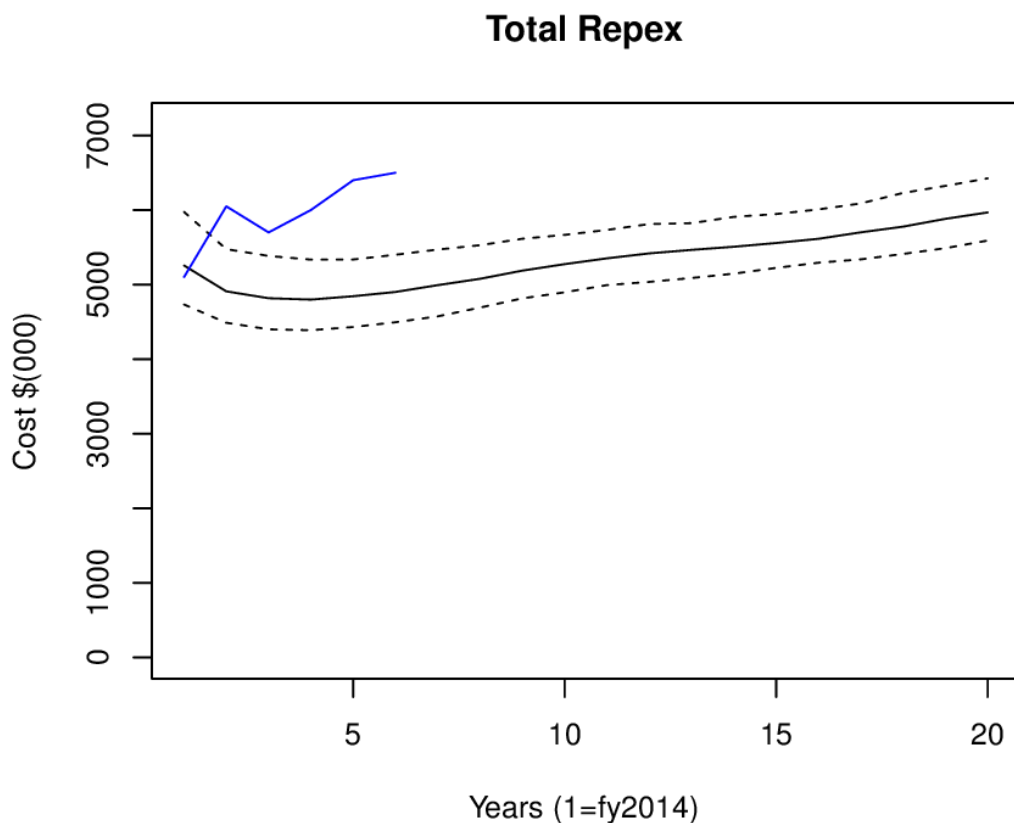

Figure 30: Replacement Capex Forecast (blue) and Model (black)

Further analysis of the individual asset age profiles for MLL assets in relation to the all-NZ average age profiles for the same asset classes



reveals no evidence of a building “backlog” of over-age assets on the Network, as further detailed in Appendix B.

### 9.1.3 Regulatory Asset Base (RAB)

The charts of Figure 31, Figure 32 and Figure 33 compare the MLL regulatory asset base (RAB) value in relation to other Network businesses.

Figure 31 shows the comparative composition where MLL shows much like the “average” business, apart from a higher proportion of Non-Network assets which derives from the inclusion of the contractor business assets. These are mainly vehicles and plant and would be excluded from other companies where maintenance and construction resources are contracted from external providers.

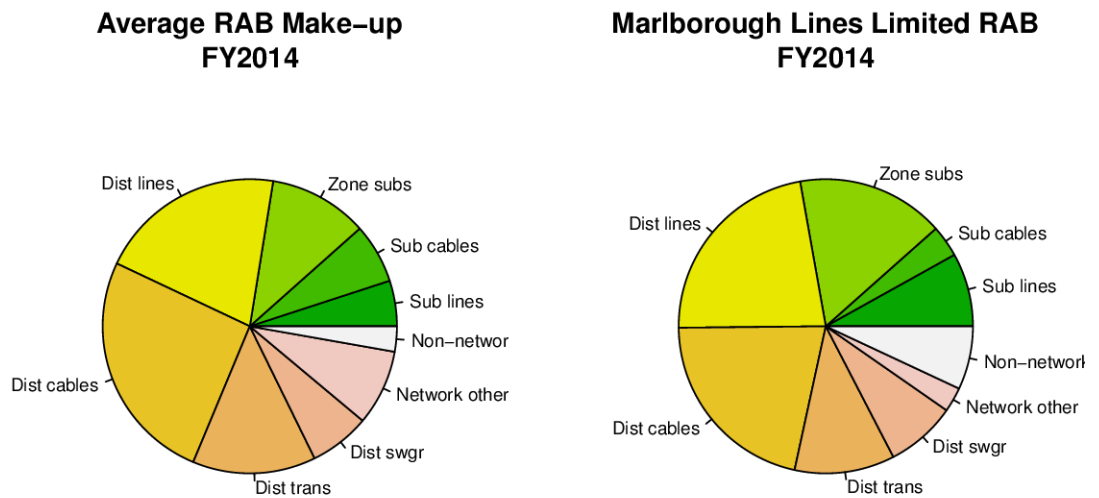
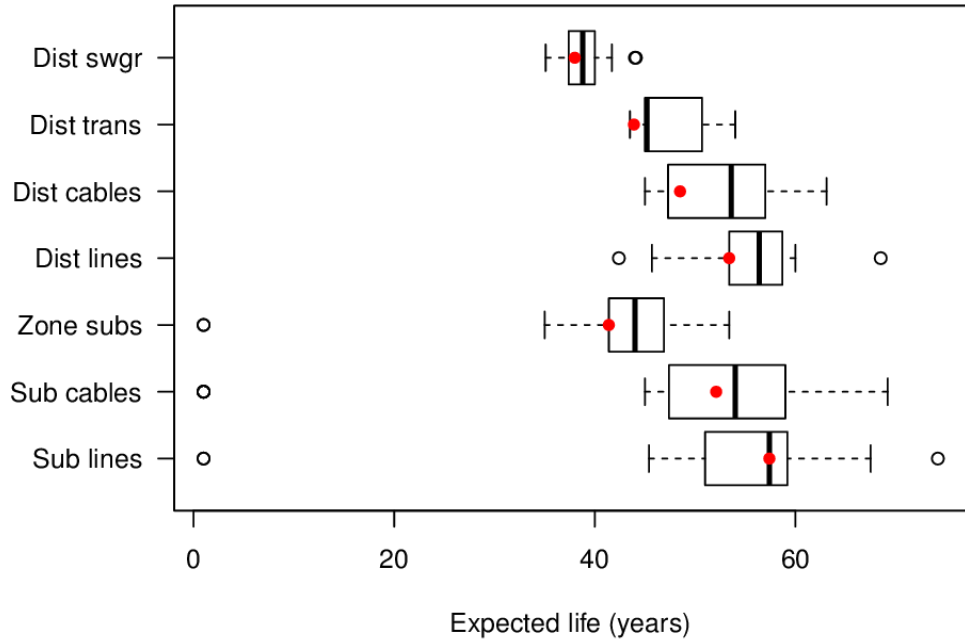

Figure 31: Comparative Composition of RAB

**Expected Lives for Assets  
FY2014 (excl. non-net & other)**



**Consumption of Expected Asset Lives (%)  
FY2014**

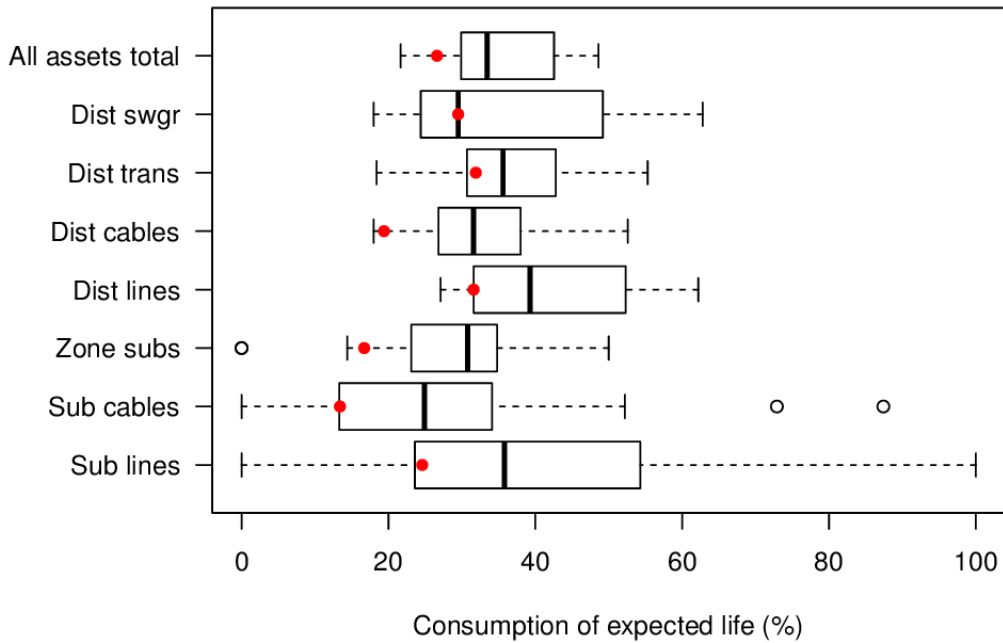
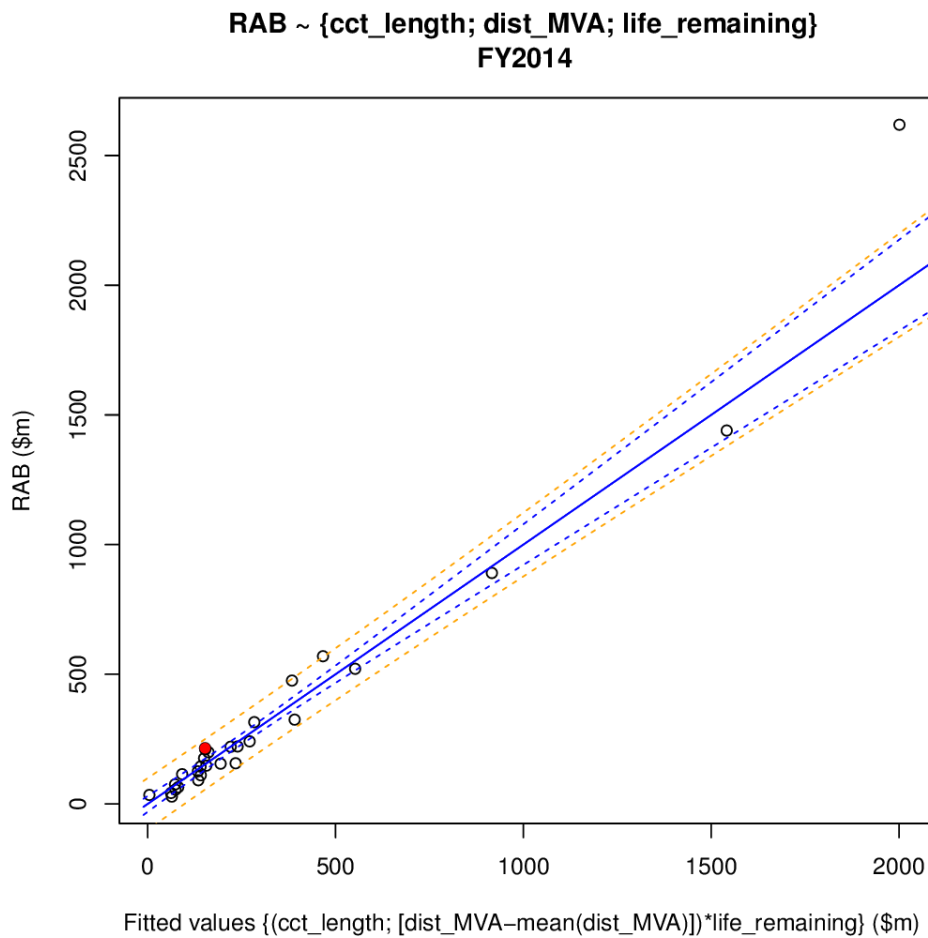

Figure 32: Depreciation-based Lives and Consumption of Life

The chart of Figure 32 (above) describes the cost-weighted depreciation-based lives and life consumption of MLL's assets compared to other businesses. MLL show within the +/- 50 percentile for expected lives apart from distribution transformers. In the comparison of consumption of life, MLL show as having a relatively low consumption of life (i.e. on a cost-weighted basis MLL is a relatively young Network) although again, most asset classes plot within the +/- 50 percentile boxes.

The chart of Figure 33 regresses the FY2014 RABs for all New Zealand distribution businesses against a measure of the Network total circuit length and transformation capacity adjusted to the weighted remaining life of the assets using standard regulatory lives. Essentially this is a comparison of the Network depreciated valuations against the size, capacity and age of the different Networks. As shown, MLL plots above the regression but within the confidence bounds of this regression. As noted previously, MLL includes the value of the internal contractor plant and vehicles which, together with the relatively low depreciated age of the assets will contribute to the above regression line position. The built value of the Network therefore appears in line with what might reasonably be expected based on the values of other businesses and in consideration of the size and age of the MLL Network.



**Figure 33: Regression for Expected RAB**

## 9.1.4 Network Reliability

The average duration of non-supply per annum (SAIDI) is the key measure of the “average” customer’s experience of supply reliability. SAIDI is derived from the multiplication of the average number of interruptions (SAIFI) and the average duration of an interruption (CAIDI). Comparative performance of both SAIFI and CAIDI measures are examined within this section of the AMP, with SAIDI looked at in section 0.

### 9.1.4.1 Comparative SAIFI

For comparison purposes, SAIFI is further divided between planned and un-planned (fault) SAIFI, both of which are regressed against Network size and type and plotted in Figure 34 and Figure 35 respectively.

Planned SAIFI is regressed against the length of non-urban overhead line (the rationale being that within urban Networks the closer meshing of the Network allows back-feeding reducing the impacts of planned outages). As the explanatory power of this regression is not high (the point scatter is very large), meaningful comparisons should be avoided, but it is at least worthy to note that MLL plots close to the regression line indicating the performance in number and impact of planned outages is, on the face of it, not unreasonable in this comparison.

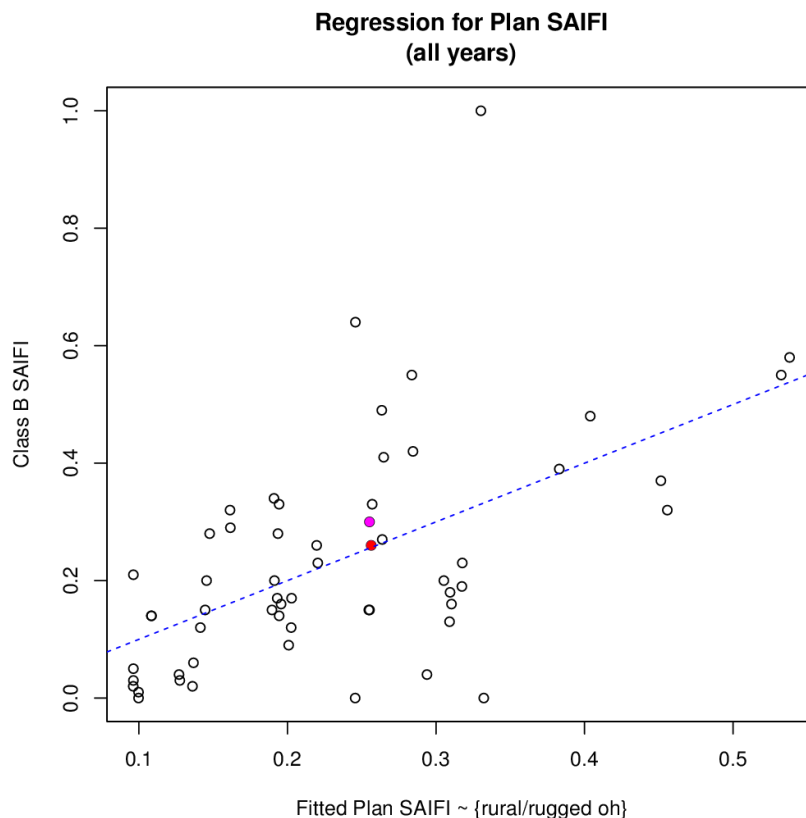

Figure 34: Regression for Plan SAIFI

Unplanned (fault) SAIFI is also regressed on the basis of the scale of exposure ( Figure 35). The explanatory power of the regression is mildly

better and shows MLL plotting below the expectation line for frequency of fault outages, even for FY2014 which was a particularly onerous year for storms and unavoidable events (such as the Seddon earthquakes).

Taking FY2013 as a more representative year, MLL shows at near frontier performance being approximately 0.5 below expectation SAIFI. This would translate to a community value of approximately \$0.9m per annum in avoided power losses.<sup>4</sup>

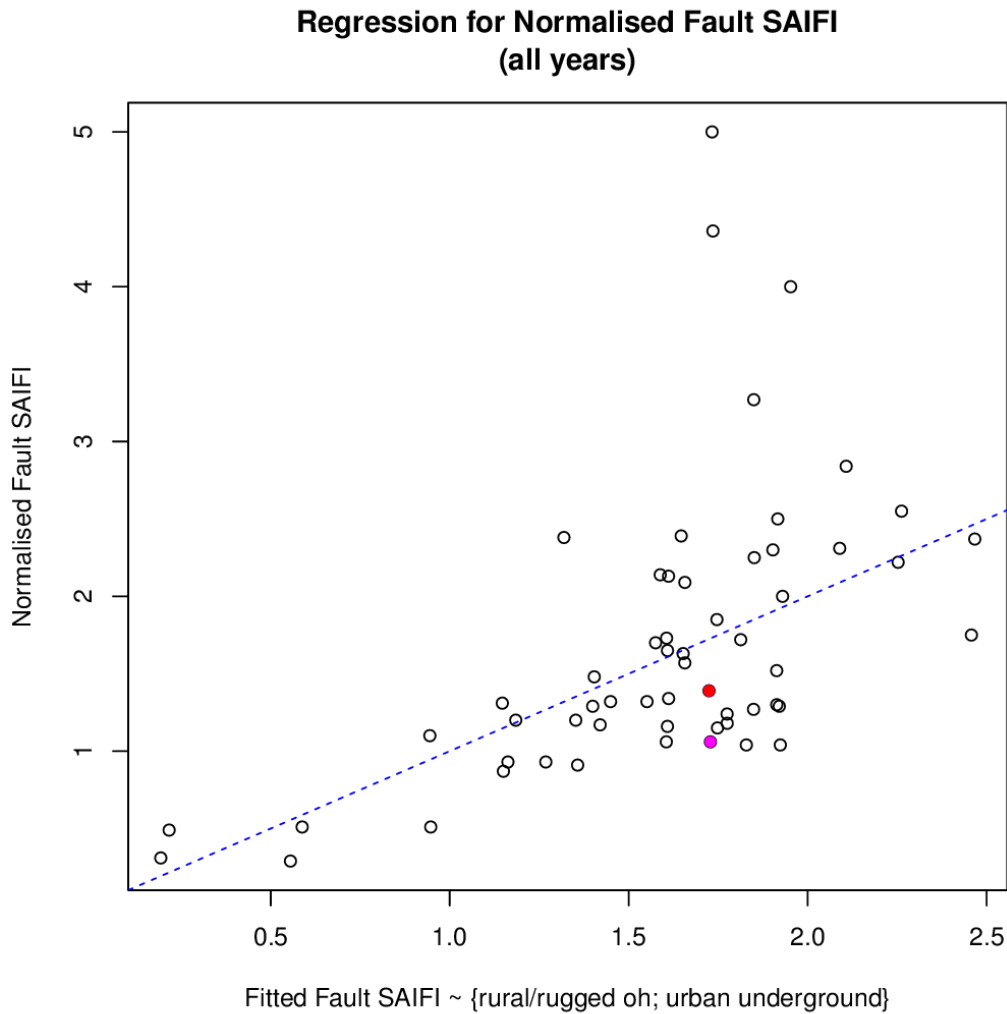

Figure 35: Regression for Normalised Fault SAIFI

The trend in overall SAIFI is also downward for MLL compared to a relatively flat trend for all distribution businesses combined, as illustrated in Figure 36 following. This, together with the lower than expectation unplanned interruption frequency, shows the MLL Network is responding to the reliability strategies being applied.

<sup>4</sup> This calculation assumes average CAIDI of 120 minutes per interruption; a loss per connection of 1.5 kW; 24,500 network customers; and a value of lost load of \$24/kWh.

### SAIFI trend for Marlborough Lines Limited

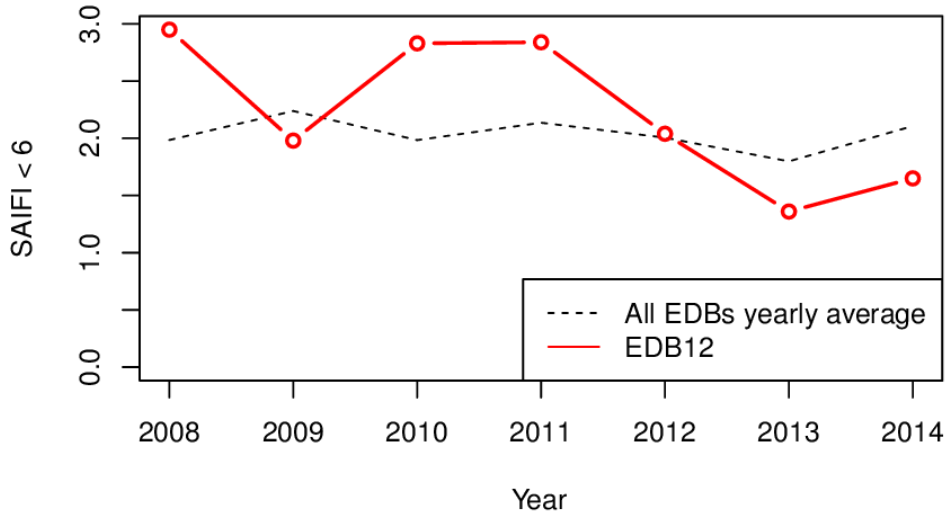

Figure 36: Total Normalised SAIFI Trend

#### 9.1.4.2 Comparative Fault Rates

SAIFI is also affected by Network design changes such as the installation of reclosers that reduce the number of customers affected by a fault. It is therefore useful to also examine the underlying fault rate as a better measure of the underlying susceptibility of the Network to faults. The charts of Figure 37 compare the fault rates per length of Network exposure in both sub-transmission and distribution (excluding LV), for overhead line and underground cable circuits. On all measures, MLL plots within the confidence bounds and mostly on the regression line apart from sub-transmission cable circuits in FY2014 which reflect faults caused by the Seddon earthquake.

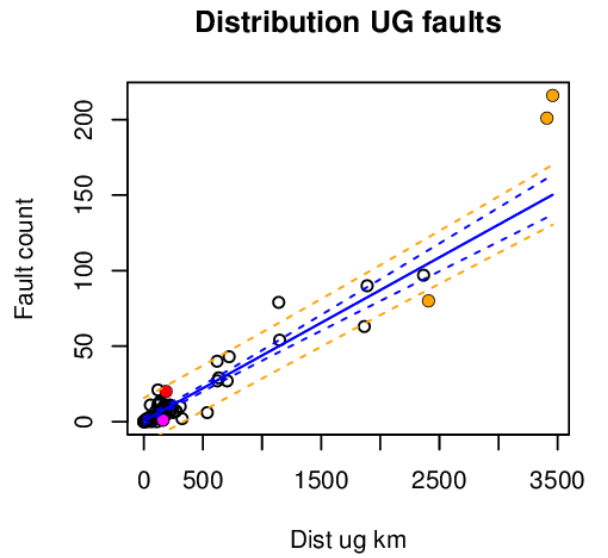
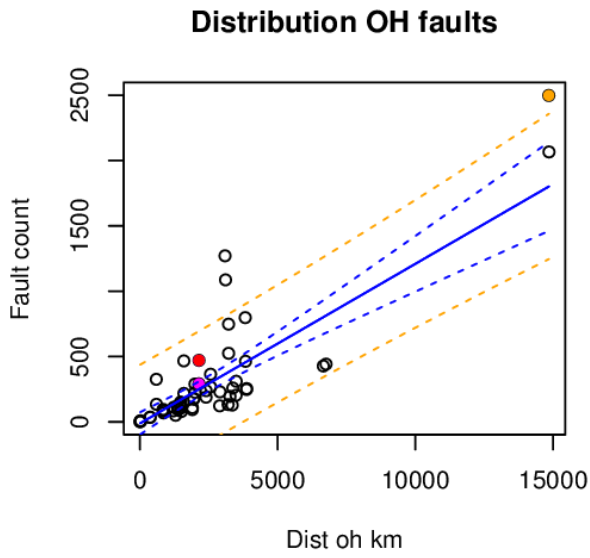
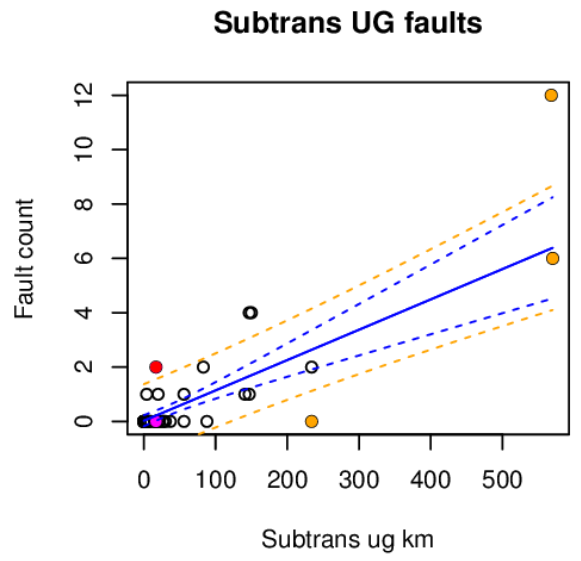
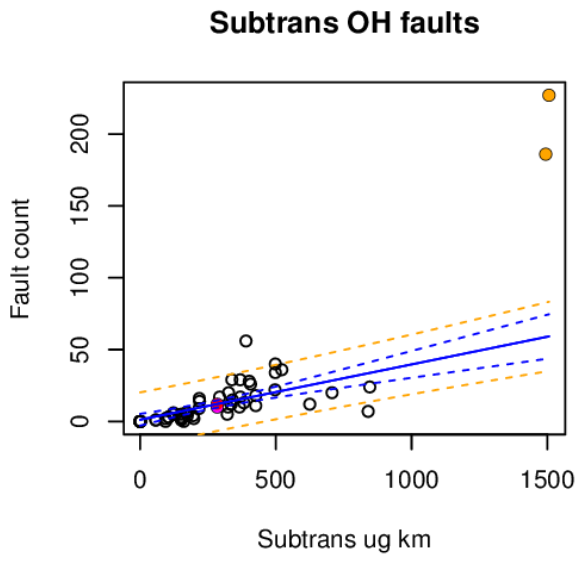

Figure 37: Fault Counts by Network Exposure

### 9.1.4.3 Comparative CAIDI

CAIDI of itself is not a particularly useful comparative measure as it does not correlate with Network exposure or other Network characteristics. Indeed, the most useful comparison is how the spread of CAIDI across time compares to the all-NZ CAIDI distribution. Even an increasing CAIDI trend is not of itself concerning as this can simply be a reflection of a Network addressing the more dominant shorter duration faults leaving a smaller number of larger duration faults to increase this average duration measure. Indeed, a gradually rising CAIDI trend is to be expected with a falling SAIFI trend and this is the case with MLL.

The distribution of CAIDI compared to the New Zealand-wide experience is illustrated in Figure 38 following and shows MLL consistently plotting within the characteristic distribution for all EDBs. The comparative CAIDI trend is presented in Figure 39 and shows a gradually increasing trend as discussed above. Given the lower than expected SAIFI, the CAIDI performance is well within the bounds of expectation on a comparative basis.

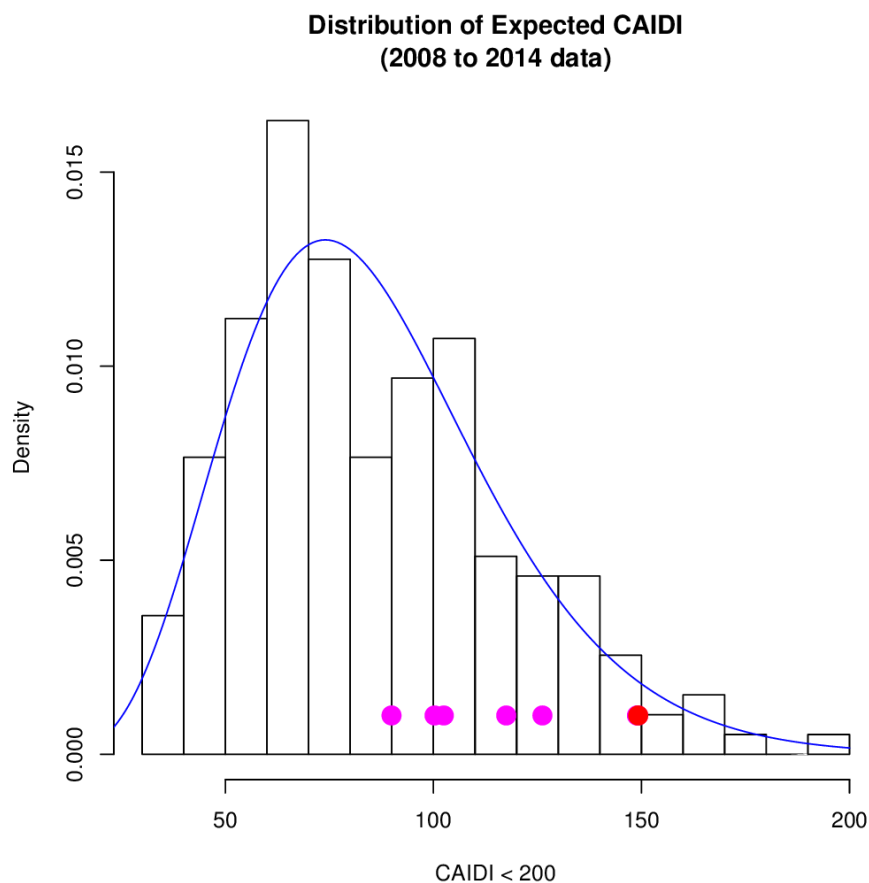

Figure 38: Distribution of CAIDI (all EDBs [bars] + MLL performance [dots])



## CAIDI trend for Marlborough Lines Limited

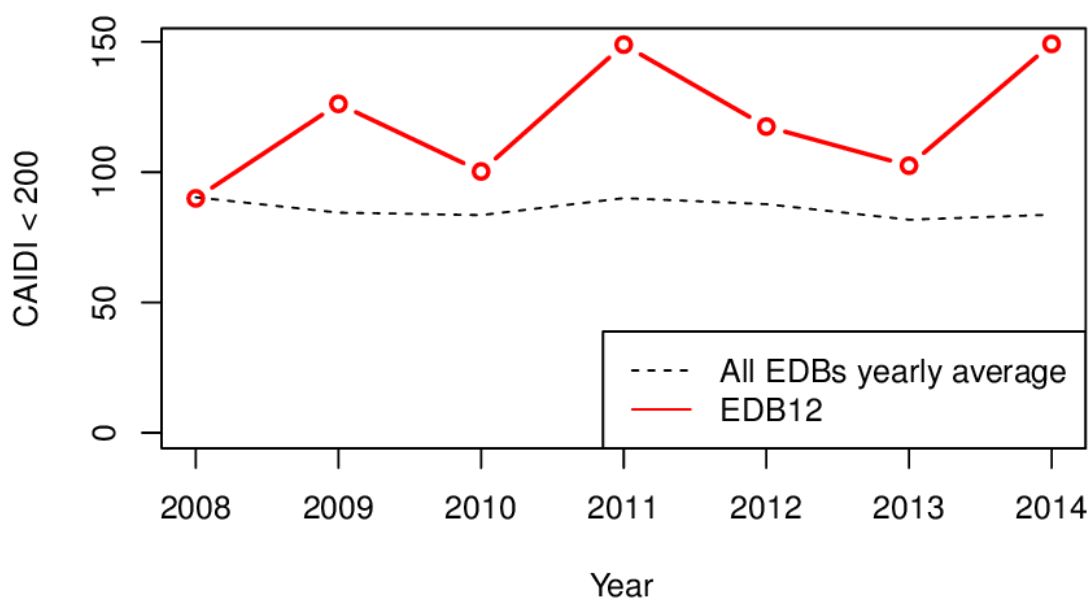

Figure 39: CAIDI Trend

### 9.1.5 Comparative Technical Performance

#### 9.1.5.1 Network Losses

Figure 40 regresses the disclosed Network losses against the energy through-put and circuit length (on a log-log scale). This shows MLL plots close to and slightly below the Network losses expectation given its circuit length and energy through-put in this comparative assessment. This indicates there no reason for concern in terms of MLL's Network conductor sizing and circuit loading arrangements.

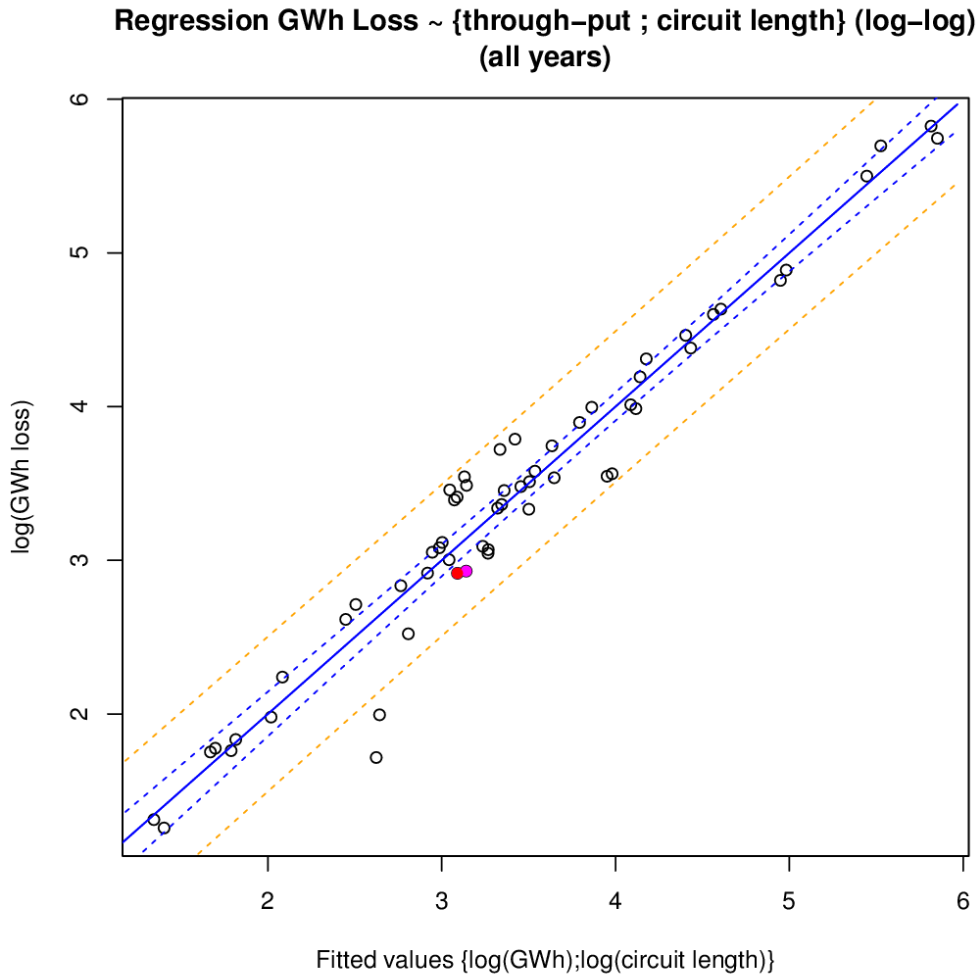

Figure 40: Expectation of Network Losses

### 9.1.5.2 Comparative Transformer Utilisation

Figure 41 regresses the disclosed distribution transformer utilisation (measured as the ratio of system maximum demand to the installed distribution transformer capacity) under three scenarios: nominal utilisation regressed against the total energy through-put per km; utilisation adjusted to remove the effect of non-standard (large industrial) loads; and utilisation adjusted to remove the effects of both non-standard loads and the non-business owned distribution transformer capacity.<sup>5</sup> In all three measures, MLL plots close to the regression expectation, particularly where the effect of non-standard load is removed. The charts indicate that, within the limitations of this performance measure, MLL's design practices for transformer sizing and loading appear reasonable.

<sup>5</sup> The points marked with orange squares are EDBs where the ratio of non-standard energy delivered is greater than 25% as this degree of non-standard load may lead to misinterpretation under this measure.

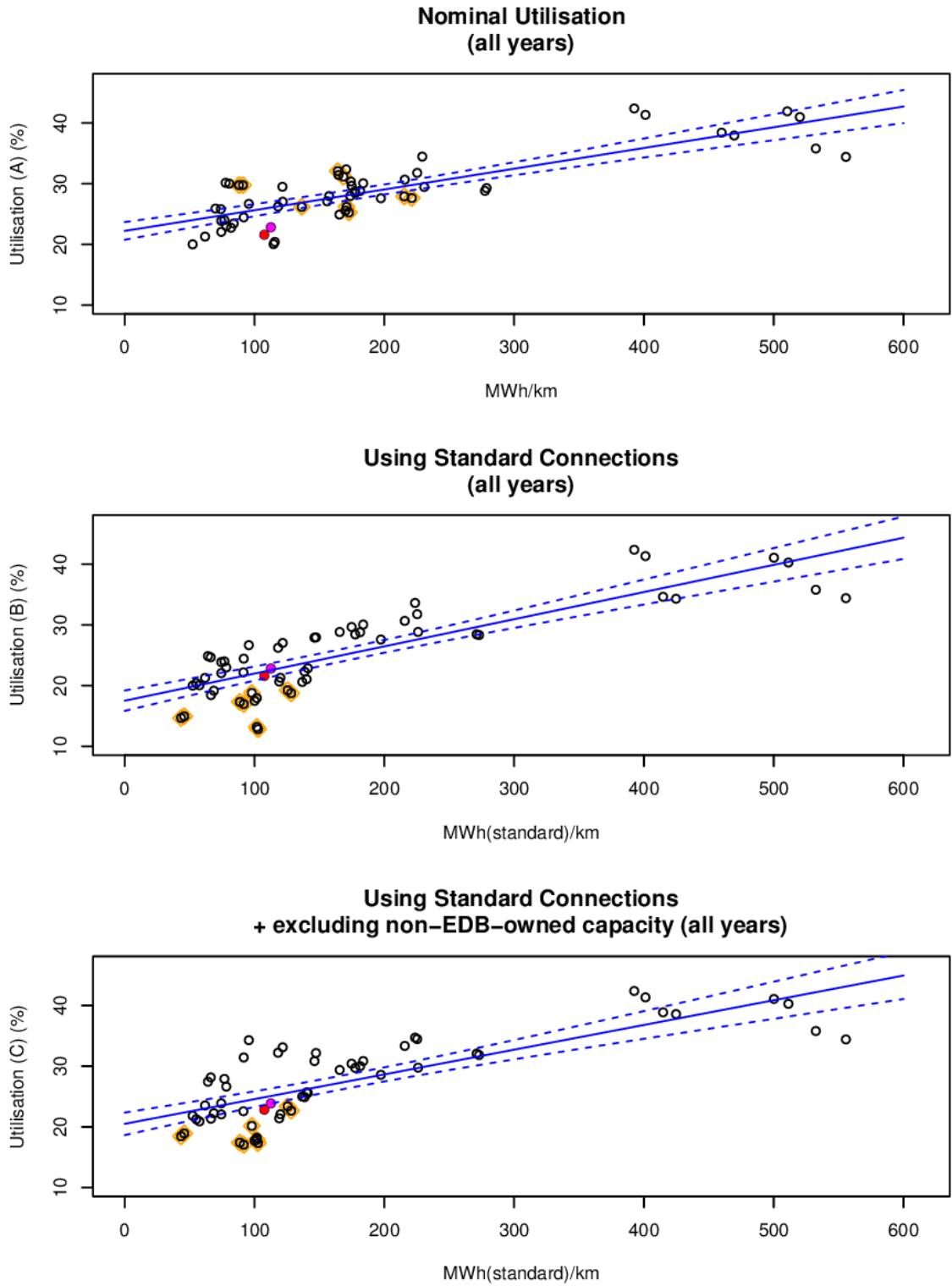

Figure 41: Distribution Transformer Utilisation

## 9.2 Performance against Service Level Targets

This section examines MLL's performance in comparison to its own service level targets.

### 9.2.1 Customer Satisfaction by Survey

Customer perception is an important component in considering business performance. This aspect of performance is measured based on informal communications with customers as well as a formal independent survey of customer views.

In addition to direct customer communication methods, MLL has several other mechanisms for indirect customer communication through its operations and commercial transactions. These include customer feedback from retailers, negotiated Use of System Agreements, negotiated Tariff schedules and Trust ownership governance.

An independent telephone survey of randomly selected Marlborough electricity customers was conducted in April 2014 to measure satisfaction with a range of performance measures, current attitudes towards MLL and customer preferences regarding company ownership and electricity industry regulation.

#### 9.2.1.1 Results

Of the sample surveyed, 90% were satisfied with reliability and quality and 90% were satisfied with the fault service. Overall, 88% of the sample was satisfied with MLL's performance against a target of greater than 90%. This indicates a general acceptance of the asset management practices of MLL. The margin of error is  $\pm 3.5\%$  at the 95% confidence level.

#### 9.2.1.2 Discussion

As seen from the survey results and the high levels of satisfaction generally, Network performance and customer expectations are well aligned.

Customer feedback is utilised at many levels in MLL's asset management planning processes. For example, at a higher level the customer's desire for improved reliability helps to set MLL's overall service level targets for system and customer supply interruption frequency and duration (SAIDI, and SAIFI). At a lower level, this customer input is used to shape asset maintenance and replacement policies, as well as to develop and analyse system reliability improvement initiatives.

In summary, MLL considers that the customer feedback received reinforces its intention to pursue incremental improvement of its Network performance justified through cost-benefit analysis, as opposed to 'step change' solutions which would involve significant additional cost.

## 9.2.2 Network Performance – Planned Outages

For the FY2014 year, MLL set a service target of planned outages being less than 80 SAIDI minutes with less than 260 planned interruptions over the Network. The historic and FY2014 performance for planned outages is illustrated in the six charts of Figure 42 below. The top left chart shows the performance and trend in planned SAIDI and shows MLL outperformed its target in this area, with a consistent downward trend on this measure, particularly in the rural and urban areas.

The top right chart shows the distribution of planned outage times where the median outage in all areas is close to six hours. The middle left chart shows 95% of the planned outages are less than 450 minutes. The middle right chart shows the distribution of customers affected per outage and indicates that most outages affect relatively small numbers of customers. This arises from MLL's policy of supporting planned outage load through Network re-configuration and placing mobile generation for outages affecting large numbers of customers, where it is economically viable to do so.

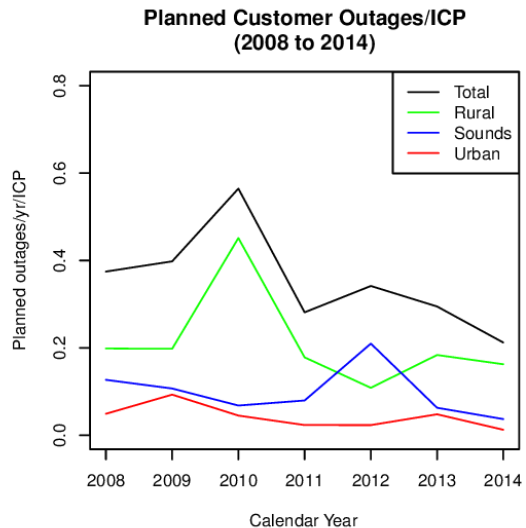
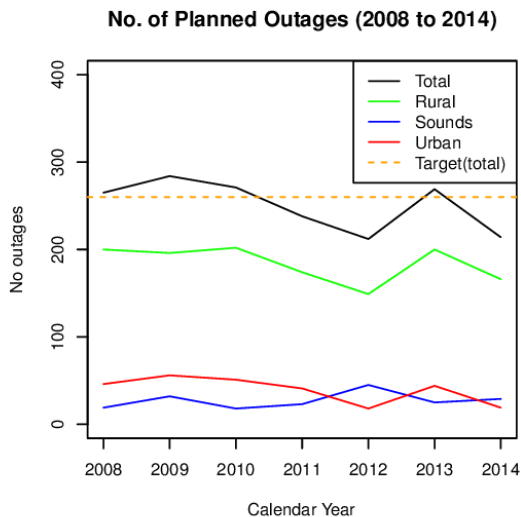
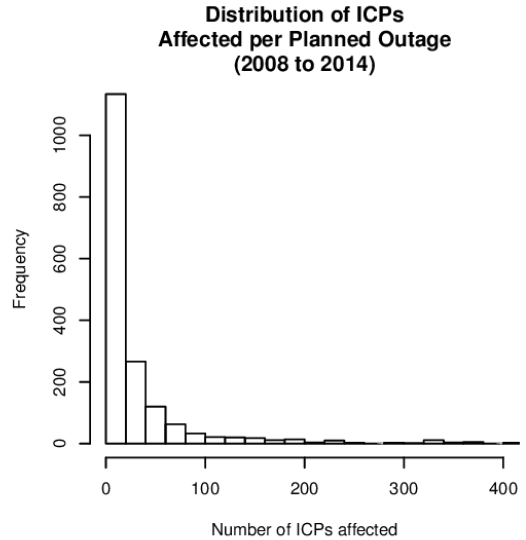
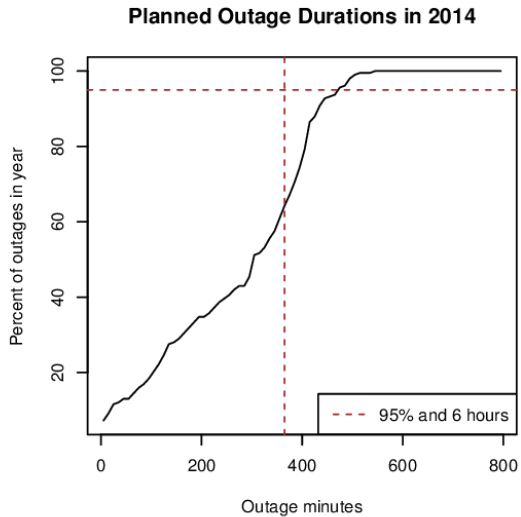
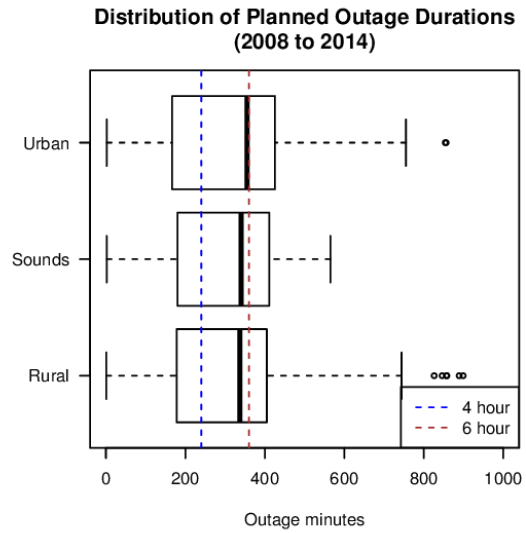
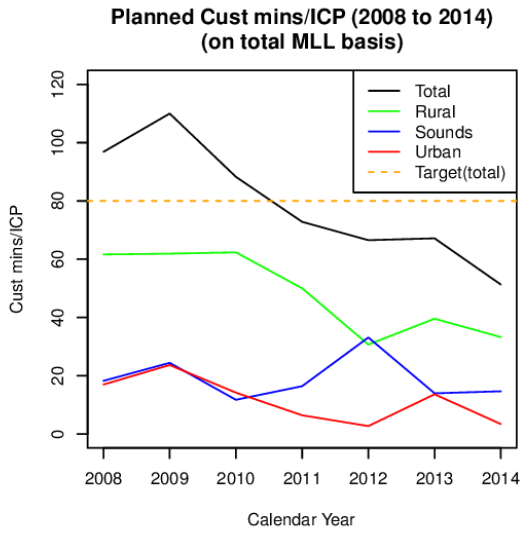

Figure 42 : Planned Outage Performance

The bottom left chart shows the performance and trend in number of planned outages per year and compares the total number of outages to the service target of less than 260. MLL's performance oscillates about this target indicating it remains a stretch target for MLL. The bottom left chart plots the number of planned outages per ICP (viz plan SAIFI ) and shows a decreasing trend much like the plan SAIDI trends of the top left chart. This indicates the gains made in plan outage performance have arisen largely through reducing the average number of customers affected per planned outage, rather than a reduction in the average time per outage. Again, this is a result of asset management policies employing mobile generation and Network re-configuration to support customer load.

Given the comparative assessment of cost, further improvements in planned outage performance will only come from initiatives that show a strong cost benefit. In this context, seeking further reductions in planned outage SAIDI is more likely through innovation in planning and work processes that reduce the average outage duration.

### 9.2.3 Network Performance – Forced Outages

For the FY2014 year, MLL set service targets for unplanned (forced) outages of:

1. Fault response times of less than or equal to:
  - a. Blenheim Urban 1.0 hours
  - b. Urban Other 1.5 hours
  - c. Rural 4.0 hours
  - d. Remote Rural 8.0 hours
2. Customers experiencing at least one outage lasting more than 8 hours: <1000
3. Customers experiencing 9 or more interruptions in the year; <2500
4. Momentary interruption [less than 1 minute] (MAIFI): < 3
5. Total SAIFI < 1.8 (average number of interruptions/ICP/yr)
6. Total SAIDI < 90 minutes with sub-targets of:
  - e. Urban SAIDI < 12 (equivalent to a SAIDI of 23 on an area population basis)
  - f. Rural SAIDI < 57 (equivalent to a SAIDI of 124 on an area population basis)
  - g. Sounds SAIDI < 21 (equivalent to a SAIDI of 252 on an area population basis)
7. Total number of fault interruptions as:
  - h. Urban area < 30
  - i. Rural area < 250
  - j. Sounds area < 60

The performance and trend in forced outages is set out in the six charts of Figure 43 below, which also identify the relevant targets. The top left chart illustrates the unplanned SAIDI over time and reveals a falling trend in all areas, although the internal SAIDI target for the Sounds was not met. The top left chart shows the distribution of outage duration times (the boxes represent the 50 percentile bounds)

and also plots the associated targets. As shown, the outage times are most varied for the remote (ie Sounds) customers as might be expected due to the time and difficulty of getting work crews to the sites. It is also noted that the internal maximum response times remain stretch targets for MLL as they are not met in all cases by any means.

The middle left chart shows the distribution of all outage times noting that approximately 95% of all outages are restored within six hours. The middle right chart shows the distribution in number of customers affected per outage. Comparison to the planned outages chart reveals the impact individual Network faults produce.



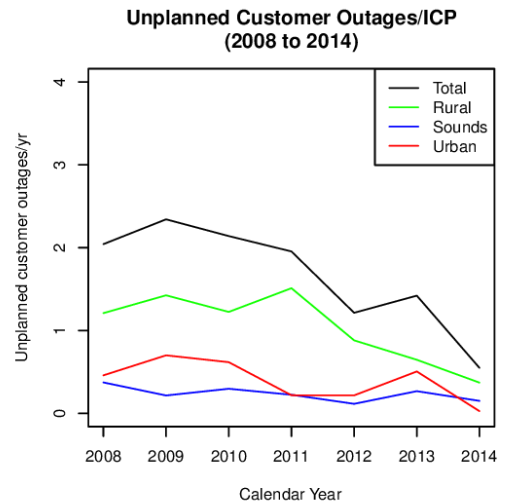
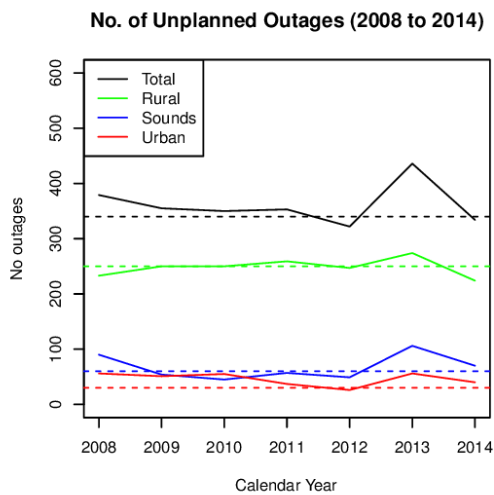
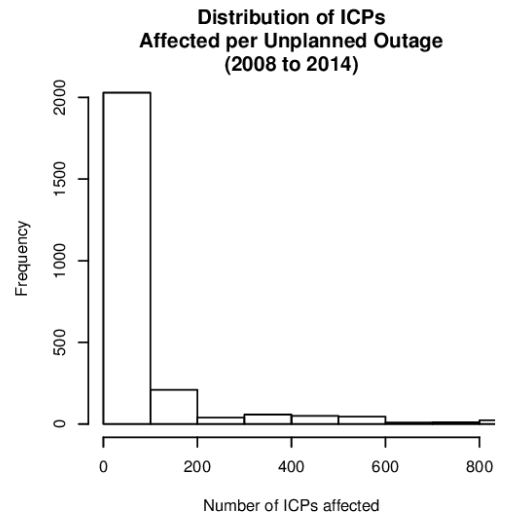
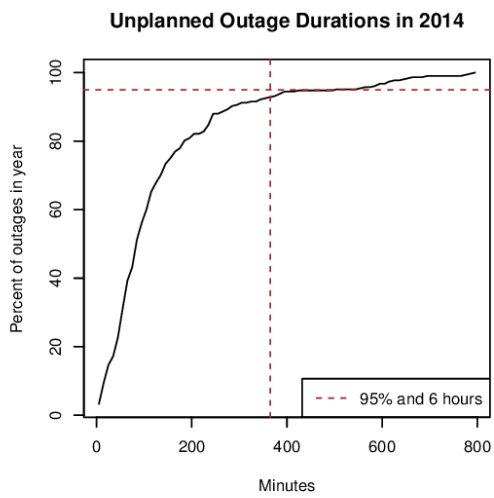
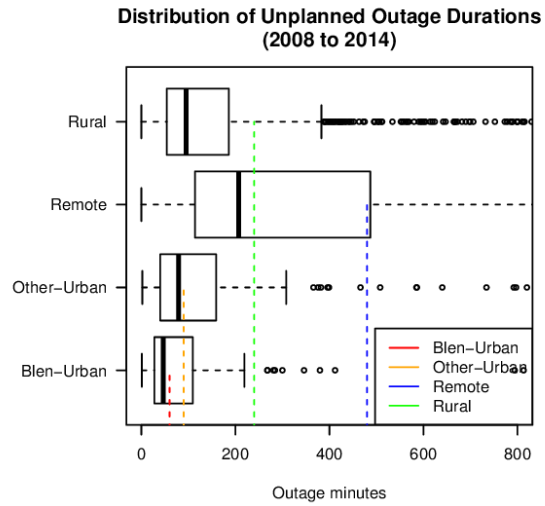
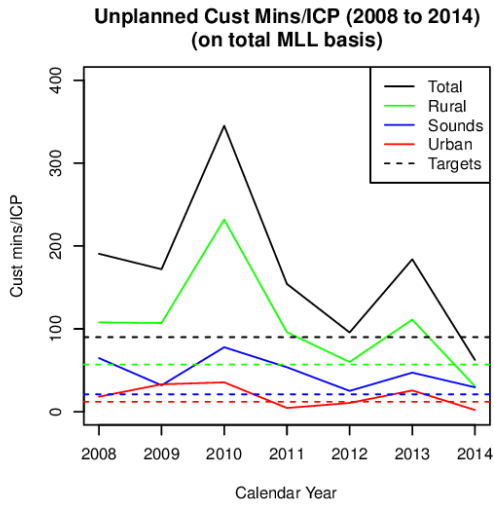

Figure 43: Unplanned outages performance

The bottom left chart shows the trend in the number of unplanned outages, which is relatively flat

The bottom left hand chart shows the number of unplanned outages per annum and where MLL's internal targets are met only in average. That is, the targets for numbers of forced outages remain as stretch targets for MLL. Further analysis of the fault categorisations shows that many faults are caused by weather and/or wind-blown materials, which is a result of the "natural" environment the overhead Network exists within. These types of faults are difficult to deal with, without resorting to expensive redesign of the Network.

The bottom right hand chart illustrates the trend in the average number of outages per customer, which shows a downward trend much like the unplanned SAIDI trend of the top left chart. Taken together with the essentially flat trend seen in the total number of outages, this reveals that the effect of the reliability measures implemented has been to reduce the numbers of customers affected by the outages which are occurring. This is largely due to the operation of the automatic re-closing switches which have been strategically placed within the Network.

#### **9.2.4 Network Outages Analysis**

Analysis of the makeup and characteristic of outages helps inform planning for future reliability initiatives.

##### **9.2.4.1 Subtransmission-Distribution Split**

The four charts of Figure 45 illustrate the split in outage performance between the 33 kV sub-transmission lines and the 11 kV distribution lines. The top row charts illustrate the number of outages by category and bottom row charts show the customer minutes by category. The left-hand charts give the average per year values (2008 to 2014) and the right hand chart shows the average per year per circuit km values. Clearly outages on the 33 kV sub-transmission have greater impact on customers but the relatively equal customer minutes per year per circuit km values indicate that MLL is managing the Network in a logical manner in terms of the reliability performance of these different parts of the Network.

The lower number of forced outage events per circuit km for the sub-transmission circuits results from both a higher maintenance emphasis on these circuits, as well as a naturally lower susceptibility to faults due to the higher insulation level. Where it is economically viable to do so, rebuilding lines at higher voltage levels is one of the strategies MLL employs, for both reliability improvement as well as "future proofing" for load growth.

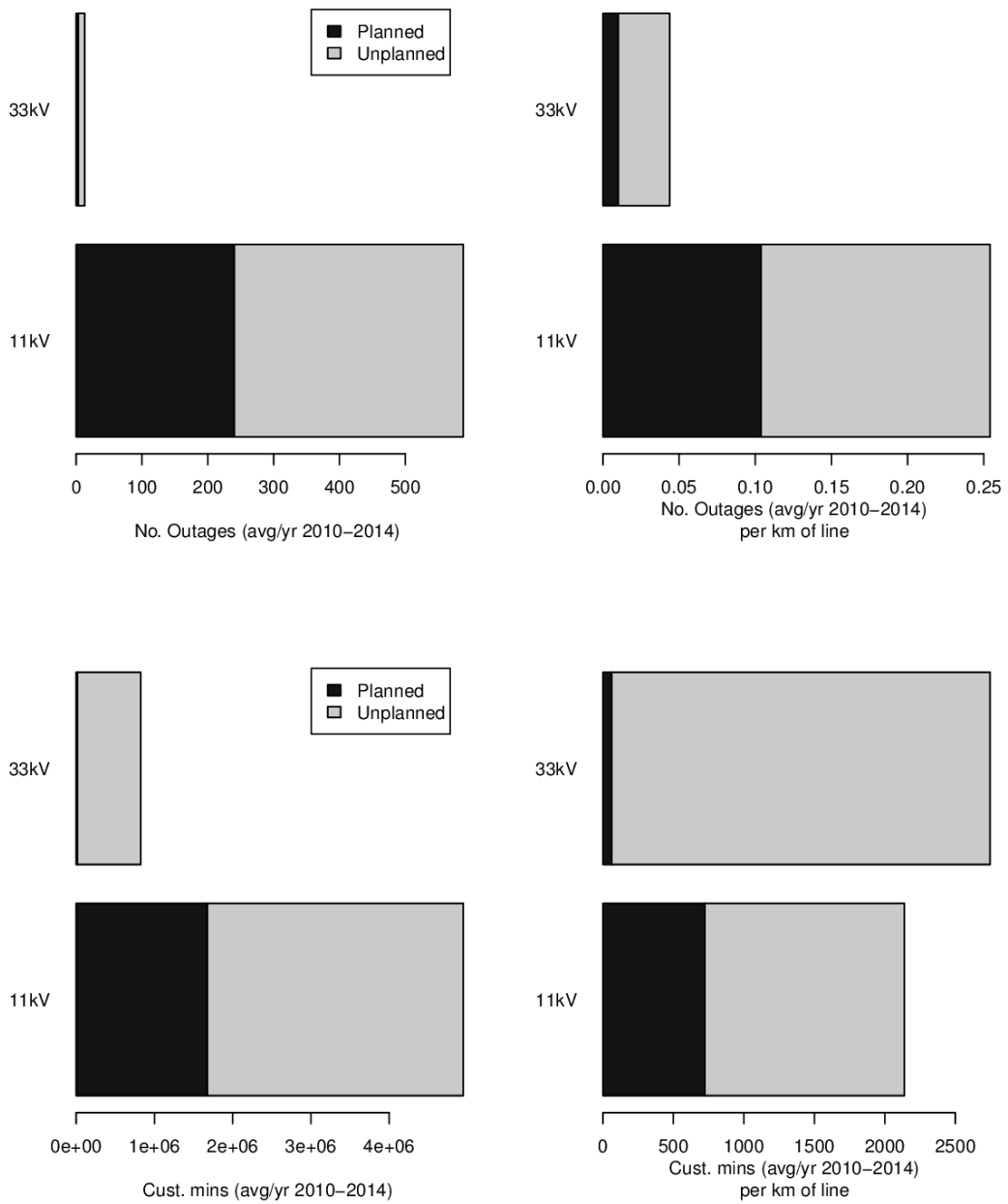

Figure 44 - Fault Causes

### 9.2.4.2 Fault Make-up

The charts of Figure 46 and Figure 47 show the makeup of fault causes for 33 kV and 11 kV circuits respectively. The charts show the spread in annual customer minutes, illustrating the natural variance in these measures, and the distribution in the outage minutes from each outage. As shown, weather is the major cause of extended outages on the sub-transmission circuits, and weather and vegetation are major causes of high impact outages on the 11 kV distribution circuits.

MLL will continue with its programme of enhanced vegetation cutting as a primary means to manage Network reliability. However, it is noted from in-depth analysis of the vegetation faults that approximately 50% of these faults now arise where the vegetation is outside the growth limit zones (usually associated with wind and wind-blown vegetation), so there will be a natural limit to the reliability gains achieved from further emphasis on vegetation management.

The incidence of animal related faults is pleasingly low and may be associated to the retro-fitting of longer possum guards on Network poles.

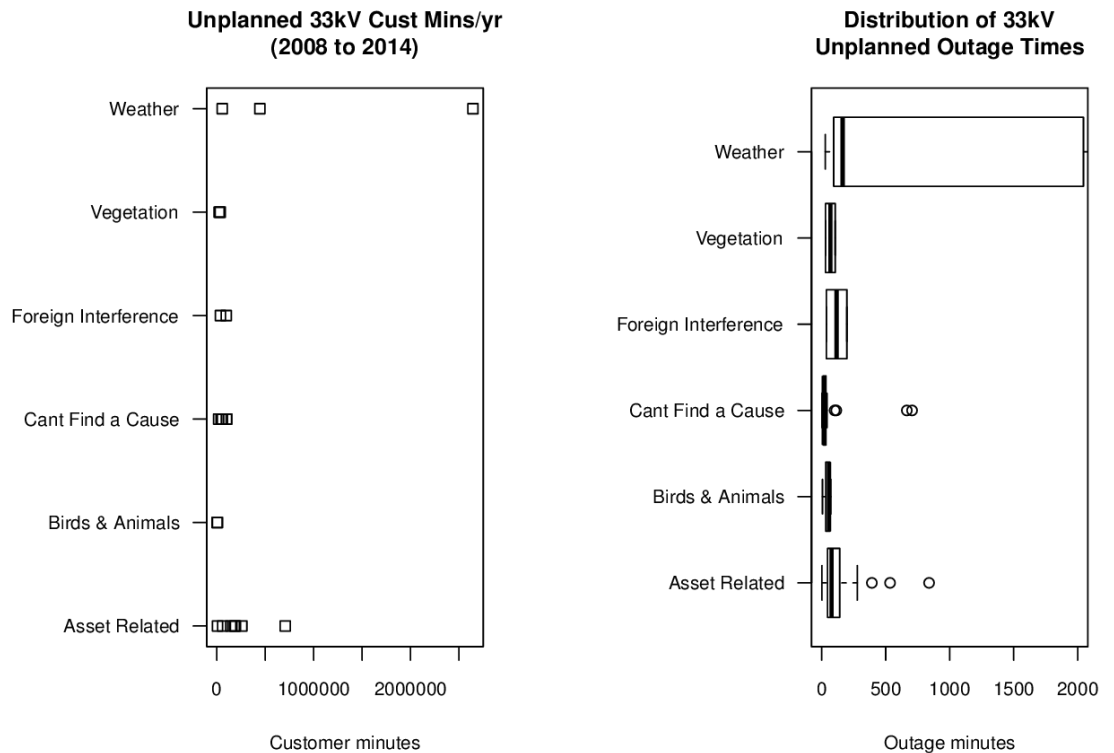

Figure 46: 33 kV outages makeup

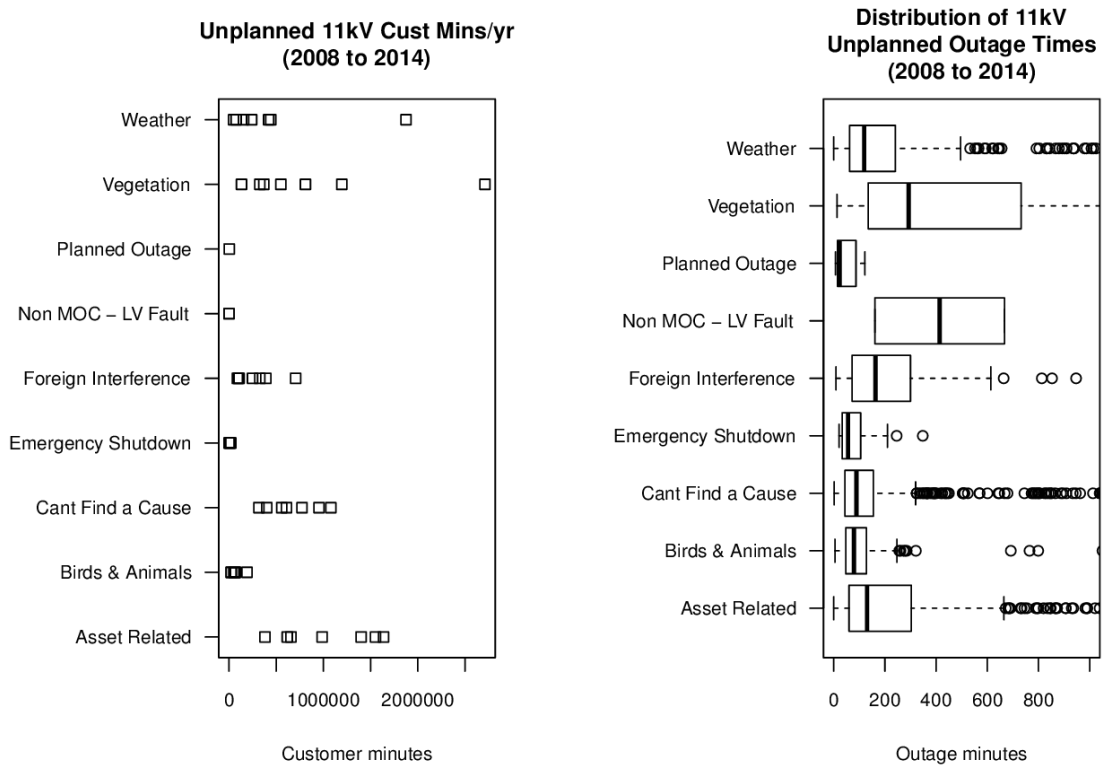

Figure 47: 11 kV outages makeup

### 9.2.4.3 Asset Related Faults

Examining the trend in the asset related fault count gives a useful indication on the management of the aging deterioration of the Network. This is illustrated in Figure 48 below and shows a declining trend in the asset related fault count indicating that MLL’s processes of asset inspection, maintenance and replacement are proving effective in managing the condition of the Network.

### Trend in Asset Related Faults (33kV and 11kV)

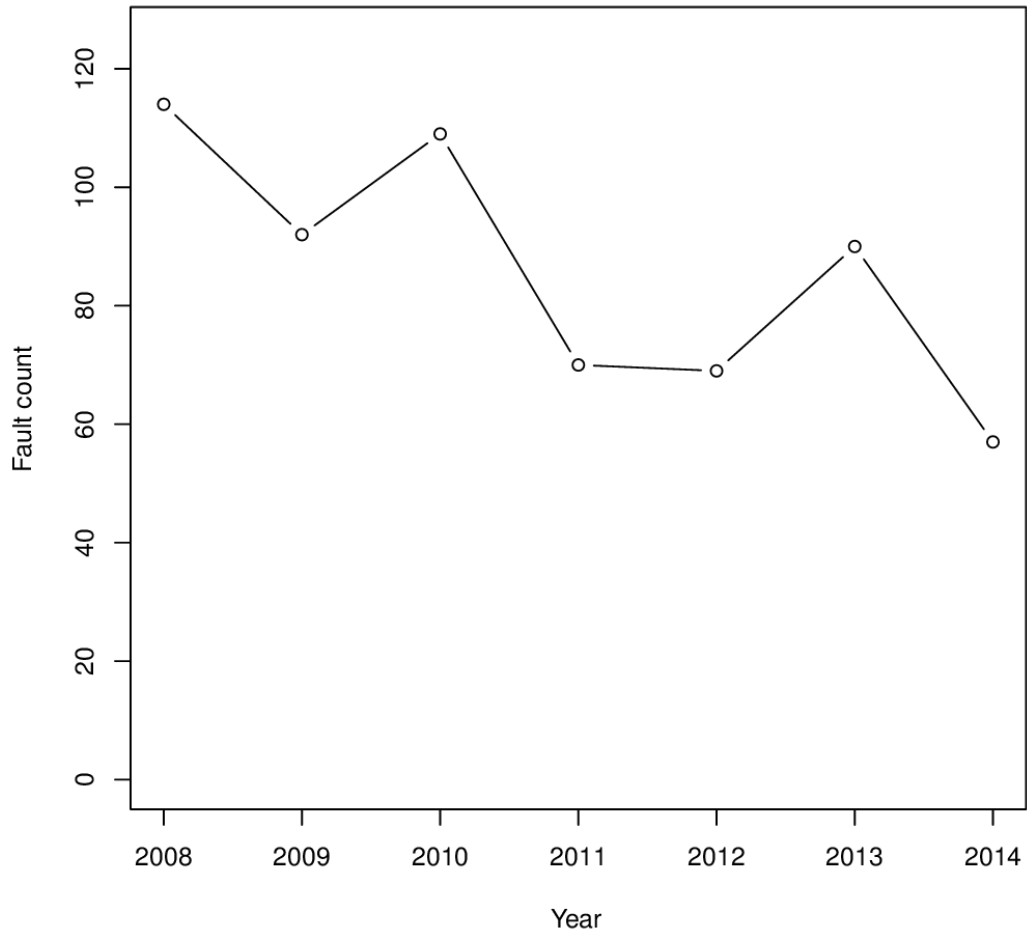

Figure 48: Asset related faults per annum

### 9.2.5 Technical Efficiency

MLL set internal targets for load factor, system losses and capacity utilisation for measuring its technical efficiency with targets and performances as listed following:

| Measure              | Target | 2010/2011 | 2011/2012 | 2012/2013 | 2013/2014 |
|----------------------|--------|-----------|-----------|-----------|-----------|
| Load factor          | 65%    | 62%       | 60%       | 61%       | 61%       |
| System losses        | 7%     | 5.1%      | 5.2%      | 4.8%      | 5.1%      |
| Capacity utilisation | 21%    | 23%       | 23%       | 23%       | 22%       |

Table 42 - Efficiency Measures Results

The load factor is influenced by the manner of load control. Historically, the load control plant was used to limit the maximum demand on MLL's Network. In recent years, load control has only been used to limit the maximum demand when the upper South Island (USI) demand is also high. This has led to an apparent

reduction in load factor as, when the USI load is low, the MLL load is allowed to rise creating a higher maximum demand and lower load factor.

The Capacity of Utilisation (CoU) is largely determined by customer requirements and patterns of use but can be influenced to a limited extent by design and operation of the Network. Every effort is made to limit the unnecessary installation of transformers and keep the CoU as high as possible. The comparative benchmarking on utilisation, set out in section 9.1.5.2, shows MLL plotting close to the regression expectation particularly where the effect of non-standard load is removed. This indicates that, within the limitations of this performance measure, MLL's design practices for transformer sizing and loading appear reasonable.

System losses are monitored and considered when designs are undertaken and transformers are purchased. It should be noted that with a large number of ICPs on annual reading only, the accuracy of the system losses figure is heavily dependent on the accurate estimation of usage for these ICPs by the Electricity Retailers. The comparative benchmarking of system losses set out in section 9.1.5.1 shows MLL's losses are close to and slightly below the regression expectation indicating MLL's conductor sizing practices appear reasonable.

### 9.3 Financial Performance Compared to Plan

The expenditure against budgets for the 2013-2014<sup>6</sup> financial year is shown in the table below:

| Item   | Actual for 2013/2014 (\$000) | Budget for 2013/2014 Year (\$000) | % Variance   |
|--|------------------------------|-----------------------------------|--------------|
| Capital Expenditure: Customer Connection                       | 273                          | 390                               | -30%         |
| Capital Expenditure: System Growth                             | 1489                         | 2410                              | -38%         |
| Capital Expenditure: Reliability, Safety and Environment       | 3108                         | 3230                              | -4%          |
| Capital Expenditure: Asset Replacement and Renewal             | 4829                         | 5100                              | -5%          |
| Capital Expenditure: Asset Relocations                         | 317                          | 390                               | -19%         |
| <b>Subtotal - Capital Expenditure on Asset Management</b>      | <b>10016</b>                 | <b>11520</b>                      | <b>-13%</b>  |
| Operational Expenditure: Routine and Preventative Maintenance  | 4812                         | 3600                              | 34%          |
| Operational Expenditure: Refurbishment and Renewal Maintenance | 480                          | 1200                              | -60%         |
| Operational Expenditure: Fault and Emergency Maintenance       | 1613                         | 1000                              | 61%          |
| <b>Subtotal - Operational Expenditure on Asset Management</b>  | <b>6905</b>                  | <b>5800</b>                       | <b>19%</b>   |
|  |                              |                                   |              |
| <b>Total Direct Expenditure on Distribution Network</b>        | <b>16921</b>                 | <b>17320</b>                      | <b>-2.3%</b> |

Table 43 – Budget and Actual Expenditure 2013/2014

<sup>6</sup> Taken from 2011 disclosures

There are significant variations against plan within individual expenditure categories but overall the expenditure was only 2.3% lower than budgeted. Operational expenditure was higher than budgeted particularly in fault maintenance. Most projects involve a range of drivers and it is often difficult to consistently categorise the expenditure. For example, a line close to the end of its useful life may become unreliable and unsafe. During its life, the load has undoubtedly grown substantially and the new line is likely to be rebuilt with more capacity. This can lead to variations in cost allocation between drivers, especially when considering projects at an initial stage compared with allocating actual costs during and after construction.

#### 9.4 Summary of AMMAT assessment

The AMMAT (Asset Management Maturity Assessment Tool) assessment is included in Appendix B. MLL undertakes some aspect of Asset Management without having detailed written procedures. In some cases this reduces the score obtained in the AMMAT. MLL recognises that as a small company, with engineering staff (many of whom are long-term employees) in an open-plan office, communication is good. Accordingly it does not have the same need for detailed formal procedures for all aspects of its Asset Management systems as some of the larger EDBs might.

Areas targeted for improvement in the short-term include:

- The procedures and documentation associated with the disposal of assets.
- Communication and consultation on the Asset Management Plan to staff.
- Management of communications, including better contact information for staff, and communications surrounding major events.
- Project sign-off/de-brief/close out – to improve this aspect of project management

Overall the AMMAT provides a high degree of confidence that robust procedures are being carried out.

#### 9.5 Performance Evaluation and Initiatives

This performance evaluation section has shown that:

- Reliability performance is very good on a comparative basis and is close to frontier performance given the type and length of Network. However, costs of vegetation management in particular appear at a threshold in relation to the value of the reliability achieved, indicating that further increases in either operational or capital expenditure to further improve reliability must be carefully evaluated. It is salient that aside from reliability considerations, Marlborough Lines also has an obligation to minimise the risk of fire and such is a factor to be considered as part of vegetation management costs.
- Reliability improvements over the last five years have largely come from reductions in the numbers of customers affected by individual outages. A shift in focus is now indicated towards reducing the average outage durations for both planned and forced outages. What can be achieved in this area is uncertain however, as the improved safety regimes that have been developed for both staff and the public which often require longer work set-up times.



- Service level targets set by MLL for reliability remain stretch targets. The next set of target values will seek to lock-in the trend line gains made to date but further reductions are not being forecast as it appears a point of diminishing returns has been reached.
- Network performance measures (losses, utilisation and load factor) meet comparative expectations against other companies' performances and therefore the current target levels for these performance measures will be retained.

While the asset age profiles in relation to New Zealand company averages indicates MLL does not have any over-hang of aged assets, a future challenge for MLL, and indeed all NZ distribution businesses, will be managing the higher capital costs of replacement compared to the initial greenfield installed values. These higher costs arise from higher equipment performance requirements, increased worker safety standards, traffic management costs, community desire for undergrounded services, pressure to remove line routes not in road reserves, and load support costs of replacing in-service equipment while managing total service reliability measures. These pressures could ultimately lead to higher Network valuation, which in turn forms the key component in determining the service costs to customers.

## 10. Capability to deliver

### 10.1 Confirmation AMP can be delivered

Marlborough Lines Limited's expenditure plans for the next five years are consistent with the levels of expenditure over the past five years. Maintaining an even flow of expenditure helps ensure that the appropriate levels of resources are available to complete work programmes.

With long life assets, in a well managed electricity network, it is possible to defer some expenditure without any obvious detrimental effects in the first few years, however longer term this strategy results in loss of reliability and service and the need for large increases in expenditure. MLL's strategy is to try and maintain an even and appropriate level of expenditure, taking into account the longer term needs of the Network, and prioritising expenditure to areas where the most benefit can be obtained.

Accordingly as the level of proposed expenditure is consistent with the levels actually achieved, it is considered that the proposed expenditure is realistic and can be achieved with current levels of resources.

### 10.2 Organisational structure

Marlborough is geographically remote from other regions and does not have sufficient population or industrial base to support multiple contractors capable of providing the plant, people and resources to operate, develop and maintain the electricity network. In addition, Marlborough can be isolated from other areas at times of severe storms and/or earthquake.

Because of these reasons, Marlborough Lines has elected to maintain an "in-house" contracting division. This helps to ensure that appropriate levels of resources are available on a 24hr/365 days basis, gives good control over contracting operations without the disadvantages of tendering in a market with low levels of competitive pressure.

The levels of resources within the contracting division have been maintained and are slightly up on historical levels.

The levels of resources within the Network to plan and manage work are at, or above, the levels available historically.

# Appendices

|              |   |           |
|--------------|---|-----------|
| <b>A</b>     | <b>Risk Register</b> .....                        | <b>2</b>  |
| <b>B</b>     | <b>Asset Renewal Performance Evaluation</b> ..... | <b>14</b> |
| <b>C</b>     | <b>Disclosure Schedules</b> .....                 | <b>24</b> |
| <b>D</b>     | <b>Zone Substation Loadings</b> .....             | <b>59</b> |
| <b>E</b>     | <b>General Network Policies</b> .....             | <b>74</b> |
| <b>E.1</b>   | <b>Non-asset Solutions</b> .....                  | <b>74</b> |
| <i>E.1.1</i> | <i>True Non-asset Solutions</i> .....             | <i>74</i> |
| <i>E.1.2</i> | <i>Partial Non-asset Solutions</i> .....          | <i>75</i> |
| <b>E.2</b>   | <b>Distributed Generation</b> .....               | <b>75</b> |
| <b>E.3</b>   | <b>Redeployment of Existing Assets</b> .....      | <b>76</b> |
| <b>E.4</b>   | <b>Upgrade of Existing Assets</b> .....           | <b>76</b> |
| <b>E.5</b>   | <b>Installation of New Assets</b> .....           | <b>76</b> |
| <b>E.6</b>   | <b>Adoption of New Technology</b> .....           | <b>77</b> |
| <b>E.7</b>   | <b>Disposal of Existing Assets</b> .....          | <b>77</b> |
| <b>E.8</b>   | <b>Safety</b> .....                               | <b>77</b> |
| <b>E.9</b>   | <b>Tangata Whenua</b> .....                       | <b>77</b> |
| <b>E.10</b>  | <b>Easements</b> .....                            | <b>78</b> |
| <b>E.11</b>  | <b>Capital Repayments</b> .....                   | <b>78</b> |
| <b>E.12</b>  | <b>Sounds Contribution</b> .....                  | <b>79</b> |
| <b>E.13</b>  | <b>Network Enhancement Contribution</b> .....     | <b>79</b> |
| <b>E.14</b>  | <b>Mobile Generators</b> .....                    | <b>79</b> |
| <b>E.15</b>  | <b>Live Line Work</b> .....                       | <b>79</b> |
| <b>E.16</b>  | <b>Maintenance</b> .....                          | <b>80</b> |
| <b>E.17</b>  | <b>Line Charges</b> .....                         | <b>80</b> |
| <b>E.18</b>  | <b>Access on to Private Property</b> .....        | <b>80</b> |
| <b>E.19</b>  | <b>Access to Network</b> .....                    | <b>80</b> |
| <b>E.20</b>  | <b>22kV Construction</b> .....                    | <b>81</b> |
| <b>E.21</b>  | <b>Pole Types</b> .....                           | <b>81</b> |
| <b>E.22</b>  | <b>Ownership of Assets</b> .....                  | <b>81</b> |
| <b>E.23</b>  | <b>Overhead or Underground Construction</b> ..... | <b>81</b> |
| <b>E.24</b>  | <b>Stores</b> .....                               | <b>81</b> |
| <b>E.25</b>  | <b>Fault Service</b> .....                        | <b>82</b> |
| <b>F</b>     | <b>Single Line Diagrams</b> .....                 | <b>83</b> |
| <b>G</b>     | <b>Liquefaction and Tsunami Zones</b> .....       | <b>85</b> |
| <b>H</b>     | <b>Glossary of Terms</b> .....                    | <b>87</b> |
| <b>I</b>     | <b>Reader Survey Form</b> .....                   | <b>89</b> |

## A Risk Register

| Risk Name   | Risk Category   | Type  | Risk Description  | Rating   | Pre-treatment Rating |
|---|---|-------|---|----------|----------------------|
| Full Supply Outage - Transpower Transmission Network Failure  | Transpower Transmission Network Failure               | Elect | The inability of the Transpower transmission network assets to safely convey electricity within the supply regulations, through the loss of key equipment at the Blenheim GXP or multiple transmission line failures. | Moderate | Considerable         |
| Full Supply Outage - Retailer Major Generation Failure        | Retailer Major Generation Failure                     | Elect | Major generation failure causing the unavailability of electricity within the supply regulations to the Marlborough region.   | Moderate | High                 |
| Partial Supply Only - Transpower Transmission Network Failure | Transpower Transmission Network Failure               | Elect | The inability of the Transpower transmission network assets to safely convey electricity within the supply regulations, due to the loss of transmission assets i.e. a supply constraint (above the Blenheim GXP).     | Moderate | Moderate             |
| Partial Supply Only - Retailer Major Generation Failure       | Retailer Major Generation Failure                     | Elect | Major generation failure causing diminished supply availability of electricity (within the supply regulations) to the Marlborough region.   | Moderate | Considerable         |
| Multiple 33kV circuits on single structure                    | MLL Distribution Network Failure                      | Elect | Waihopai and Redwoodtown feeders along Murphys Road   | Moderate | Moderate             |
| Major Earthquake Damage to MLL Distribution Assets            | Natural Environment Impact on MLL Distribution Assets | Env   | Major natural environment impact on MLL distribution assets causing the unavailability of electricity supply to part or all of the Marlborough region.  | Moderate | Considerable         |
| Price Path Threshold Regime Breach                            | Commerce Commission Threshold Regime Breach           | Bus   | Price Path threshold regime breach, leading to investigation and possible targeted control of MLL (price setting)   | Moderate | Considerable         |

| <b>Risk Name</b>                                  | <b>Risk Category</b>                                  | <b>Type</b> | <b>Risk Description</b>   | <b>Rating</b> | <b>Pre-treatment Rating</b> |
|---|---|-------------|---|---------------|-----------------------------|
| MLL Staff Injury / Incident                       | MLL Distribution Network Access and Control Breakdown | Bus         | A network incident or personnel injury, due to the breakdown of the MLL network access and control systems.   | Some          | Considerable                |
| Quality Threshold Regime Breach                   | Commerce Commission Threshold Regime Breach           | Bus         | Quality threshold regime breach, leading to investigation and possible targeted control of MLL (price setting)  | Some          | Considerable                |
| 33kV Overhead Line Failure                        | MLL Distribution Network Failure                      | Elect       | The inability of the MLL distribution network assets to safely convey electricity within the supply regulations. Highest risk - high wind speed activity or snow loading. | Some          | Moderate                    |
| Lightning Storm Damage to MLL Distribution Assets | Natural Environment Impact on MLL Distribution Assets | Env         | A lightning storm resulting in damage to MLL distribution assets causing the unavailability of electricity supply to part or all of the Marlborough region.               | Low           | Moderate                    |
| Contractor Injury / Incident                      | MLL Distribution Network Access and Control Breakdown | Bus         | A contractor incident or personnel injury, due to the breakdown of the MLL network access and control systems.  | Low           | Moderate                    |
| Public Injury / Incident                          | MLL Distribution Network Access and Control Breakdown | Bus         | A member of the public has an incident or personnel injury, due to the breakdown of the MLL network access and control systems.   | Low           | Some                        |
| ABS & HV Fuse Failure                             | MLL Distribution Network Failure                      | Elect       | The inability of the MLL distribution network assets to safely convey electricity within the supply regulations. Highest risk - lightning or high wind speed activity.    | Low           | Moderate                    |
| Ring Main Unit Failure                            | MLL Distribution Network Failure                      | Elect       | The inability of the MLL distribution network assets to safely convey electricity within the supply regulations. Highest risk - earthquake or flood activity.             | Low           | Some                        |

| <b>Risk Name</b>   | <b>Risk Category</b>                                  | <b>Type</b> | <b>Risk Description</b>   | <b>Rating</b> | <b>Pre-treatment Rating</b> |
|--|---|-------------|---|---------------|-----------------------------|
| High Winds Causing Damage to MLL Distribution Assets       | Natural Environment Impact on MLL Distribution Assets | Env         | Natural environment impact on MLL distribution assets causing the unavailability of electricity supply to part or all of the Marlborough region.                                | Low           | Moderate                    |
| Switching structures                                       | MLL Distribution Network Failure                      | Elect       | An entire switching structure is compromised and all switching structure switches are inoperable  | Low           | Moderate                    |
| Fault Security Constraint at Havelock Zone Sub             | MLL Distribution Network Failure                      | Elect       | 100% of the time this sub only has a "n" fault security level, meaning any fault issues at this sub would definitely result in a network outage.                                | Low           | Some                        |
| 11kV Cable Failure   | MLL Distribution Network Failure                      | Elect       | 11kV cable failure causing the inability of the MLL distribution network assets to safely convey electricity within the supply regulations. Highest risk - earthquake activity. | Low           | Some                        |
| 11kV Overhead Line Failure                                 | MLL Distribution Network Failure                      | Elect       | The inability of the MLL distribution network assets to safely convey electricity within the supply regulations. Highest risk - high wind speed activity or snow loading.       | Low           | Moderate                    |
| 33kV UG Cable Failure Due to 3rd Party (excavation) Damage | MLL Distribution Network Failure                      | Elect       | 33kV UG cable failure causes the loss of supply to MLL distribution network assets and therefore the loss of a subtrans circuit or a zone substation.                           | Low           | Moderate                    |
| Power TX Failure   | MLL Distribution Network Failure                      | Elect       | The inability of the MLL distribution network assets to safely convey electricity within the supply regulations. Highest risk - earthquake activity.                            | Low           | Considerable                |
| Fault Security Constraint at Rai Valley Zone Sub           | MLL Distribution Network Failure                      | Elect       | 100% of the time this sub only has a "n" fault security level, meaning any fault issues at this sub would definitely result in a network outage.                                | Low           | Some                        |

| <b>Risk Name</b>   | <b>Risk Category</b>                                  | <b>Type</b> | <b>Risk Description</b>  | <b>Rating</b> | <b>Pre-treatment Rating</b> |
|--|---|-------------|--|---------------|-----------------------------|
| 400V UG Cable Failure Due to 3rd Party (excavation) Damage | MLL Distribution Network Failure                      | Elect       | The inability of the MLL distribution network assets to safely convey electricity within the supply regulations.   | Low           | Some                        |
| Single 33kV Supply to Linkwater Zone Sub                   | MLL Distribution Network Failure                      | Elect       | The single 33kV supply to Linkwater zone sub means that a failure in this line or the equipment that connects it to the wider network, will result in a zone substation outage.  | Low           | Some                        |
| Landslide Damage to MLL Distribution Assets                | Natural Environment Impact on MLL Distribution Assets | Env         | Natural environment impact on MLL distribution assets causing the unavailability of electricity supply to part or all of the Marlborough region.                                 | Low           | Some                        |
| Single 33kV Supply to Rai Valley Zone Sub                  | MLL Distribution Network Failure                      | Elect       | The single 33kV supply to Rai Valley zone sub means that a failure in this line or the equipment that connects it to the wider network, will result in a zone substation outage. | Low           | Some                        |
| Single 33kV Supply to Ward Zone Sub                        | MLL Distribution Network Failure                      | Elect       | The single 33kV supply to Ward zone sub means that a failure in this line or the equipment that connects it to the wider network, will result in a zone substation outage.       | Low           | Some                        |
| 33kV Cable Failure   | MLL Distribution Network Failure                      | Elect       | The inability of the MLL distribution network assets to safely convey electricity within the supply regulations. Highest risk - earthquake activity.                             | Low           | Moderate                    |
| Single 33kV Supply to Leefield Zone Sub                    | MLL Distribution Network Failure                      | Elect       | The single 33kV supply to Leefield zone sub means that a failure in this line or the equipment that connects it to the wider network, will result in a zone substation outage.   | Low           | Some                        |

| <b>Risk Name</b>   | <b>Risk Category</b>                                  | <b>Type</b> | <b>Risk Description</b>  | <b>Rating</b> | <b>Pre-treatment Rating</b> |
|--|---|-------------|--|---------------|-----------------------------|
| Vegetation Clearance from MLL Overhead Distribution Assets | Vegetation Control                                    | Elect       | Failure to maintain clearance reduces network reliability, would breach a statutory requirement (tree regs 2003), incurs significant 'catch up' costs and may present a serious safety risk to staff & general public. | Very low      | Moderate                    |
| Availability of Roothing Network                           | MLL Distribution Network Failure                      | Elect       | Analysis and past experience has revealed that restoration of power supply during civil defence emergencies is very dependant on the availability of the rooding network for access.                                   | Very low      | Low                         |
| 11kV UG Cable Failure Due to 3rd Party (excavation) Damage | MLL Distribution Network Failure                      | Elect       | 11kV UG cable failure causes the loss of supply to MLL distribution network assets and therefore the loss of an 11kV circuit or a feeder.  | Very low      | Some                        |
| Indoor Switchgear Failure                                  | MLL Distribution Network Failure                      | Elect       | The inability of the MLL distribution network assets to safely convey electricity within the supply regulations. Highest risk - earthquake activity.   | Very low      | Moderate                    |
| Transformer Oil Spill (In-Situ or in Transit)              | MLL Distribution Assets Impact on Natural Environment | Env         | Major natural environment impact caused by transformer oil contaminating soil, waterways or stormwater drains, etc.  | Very low      | Moderate                    |
| Network Asset (or related) Site Security                   | Vandalism and Public Nuisance                         | Bus         | Disruption to the operation of MLL electricity distribution network through acts of vandalism and public nuisance.   | Very low      | Moderate                    |
| Poor Workmanship Faults                                    | MLL Distribution Network Failure                      | Elect       | Poor workmanship faults resulting in the inability of the MLL distribution network assets to safely convey electricity within the supply regulations.  | Very low      | Some                        |



| <b>Risk Name</b>                                 | <b>Risk Category</b>             | <b>Type</b> | <b>Risk Description</b>   | <b>Rating</b> | <b>Pre-treatment Rating</b> |
|--|----------------------------------|-------------|---|---------------|-----------------------------|
| 400V Overhead Line Failure                       | MLL Distribution Network Failure | Elect       | The inability of the MLL distribution network assets to safely convey electricity within the supply regulations. Highest risk - high wind speed activity or snow loading. | Very low      | Some                        |
| Land Access Difficulties                         | Land Access Difficulties         | Reg         | MLL is unable to access land to site its equipment or get access across to construct existing assets  | Very low      | Moderate                    |
| Multiple 33kV circuits on single structure       | MLL Distribution Network Failure | Elect       | Picton 1 and 2 Feeders between O'Dwyers Road and Tuamarina, especially a pole on SH1 north of Wairau River bridge   | Very low      | Some                        |
| Multiple 11kV circuits on single structure       | MLL Distribution Network Failure | Elect       | Talleys and Renwick Feeders along Old Renwick Road  | Very low      | Some                        |
| Pole Mounted TX Failure                          | MLL Distribution Network Failure | Elect       | The inability of the MLL distribution network assets to safely convey electricity within the supply regulations. Highest risk - lightning or earthquake activity.         | Very low      | Some                        |
| Ground Mounted TX Failure                        | MLL Distribution Network Failure | Elect       | The inability of the MLL distribution network assets to safely convey electricity within the supply regulations. Highest risk - earthquake activity or flood.             | Very low      | Some                        |
| Fault Security Constraint at Riverlands Zone Sub | MLL Distribution Network Failure | Elect       | 20% of the time this sub only has a "n" fault security level, meaning any fault issues at this sub during this time would definitely result in a network outage.          | Very low      | Low                         |
| Fault Security Constraint at Seddon Zone Sub     | MLL Distribution Network Failure | Elect       | 10% of the time this sub only has a "n" fault security level, meaning any fault issues at this sub during this time would definitely result in a network outage.          | Very low      | Very low                    |

| <b>Risk Name</b>                                     | <b>Risk Category</b>                                  | <b>Type</b> | <b>Risk Description</b>   | <b>Rating</b> | <b>Pre-treatment Rating</b> |
|--|---|-------------|---|---------------|-----------------------------|
| Maintenance Security Constraint at Havelock Zone Sub | MLL Distribution Network Failure                      | Elect       | 35% of the time this sub only has a "n" maintenance security level, meaning any maintenance activity during these times would definitely involve a shutdown. Maintenance security achieved by 11kV tie.                 | Very low      | Very low                    |
| Car versus Pole or Equipment                         | MLL Distribution Network Failure                      | Elect       | The inability of the MLL distribution network assets to safely convey electricity within the supply regulations. Highest risk - high traffic density, access constricted areas and poor network design.                 | Insignificant | Moderate                    |
| Access Track Clearance                               | Vegetation Control                                    | Elect       | Constant effort is required to keep tracks clear so that assets can be accessed in the Marlborough Sounds. Failure to do so makes the network less reliable and increases network fault repair/response times.          | Insignificant | Some                        |
| Land Access Difficulties                             | Land Access Difficulties                              | Reg         | MLL is unable to access land to site its equipment or get access across to service / inspect / upgrade existing assets or vegetation.   | Insignificant | Moderate                    |
| Micro Generation Interconnection                     | Disruptive Technologies                               | Bus         | The impact disruptive technologies on the MLL network supply quality, voltage regulation, etc.  | Insignificant | Moderate                    |
| Unlawful or Unsafe Network Connection                | MLL Distribution Network Access and Control Breakdown | Elect       | The inability of the MLL distribution network to safely convey electricity within the supply regulations, due to the breakdown of the MLL network access and control systems i.e. unlawful or unsafe network connection | Insignificant | Moderate                    |
| Multiple 33kV circuits on single structure           | MLL Distribution Network Failure                      | Elect       | Redwood Pass and Dashwood Pass lines south of Riverlands and again north of Seddon  | Insignificant | Some                        |

| <b>Risk Name</b>                           | <b>Risk Category</b>               | <b>Type</b> | <b>Risk Description</b>  | <b>Rating</b> | <b>Pre-treatment Rating</b> |
|--|------------------------------------|-------------|--|---------------|-----------------------------|
| Multiple 33kV circuits on single structure | MLL Distribution Network Failure   | Elect       | Two branches of Rai Valley feeder along floor of Kaituna Valley  | Insignificant | Some                        |
| Adequate Fuel Supply                       | MLL Distribution Network Failure   | Elect       | Analysis and past experience has revealed that restoration of power supply during civil defence emergencies is very dependant on the availability of adequate fuel supplies.             | Insignificant | Some                        |
| Multiple 11kV circuits on single structure | MLL Distribution Network Failure   | Elect       | Renwick and Kaituna feeders along Anglesea St  | Insignificant | Low                         |
| Multiple 11kV circuits on single structure | MLL Distribution Network Failure   | Elect       | Waikawa and Buller Street feeders along Canterbury Street  | Insignificant | Low                         |
| Inadequate emergency stock                 | Stores                             | Elect       | MLL does not have adequate stock on hand to repair faults in the network   | Insignificant | Low                         |
| Ripple signal failure                      | MLL Distribution Network Failure   | Elect       | A problem at system control that causes 1 or more injection cells to fail to send a ripple signal  | Insignificant | Low                         |
| MI Asset or Equipment Obsolescence         | MI Asset or Equipment Obsolescence | Bus         | Assets or equipment owned by MLL becomes obsolete due to business requirements   | Insignificant | Some                        |
| 400V Box Failure                           | MLL Distribution Network Failure   | Elect       | The inability of the MLL distribution network assets to safely convey electricity within the supply regulations. Highest risk - vehicle damage or flood.                                 | Insignificant | Some                        |
| Distributed Generation - Fuel Cells        | Disruptive Technologies            | Bus         | Disruptive technologies have the potential to lower MLL revenues and hence asset value (i.e. island networks that only need back up supply therefore line charge but no delivery charge) | Insignificant | Moderate                    |
| 400V Cable Failure                         | MLL Distribution Network Failure   | Elect       | The inability of the MLL distribution network assets to safely convey electricity within the supply regulations. Highest risk - earthquake activity.                                     | Insignificant | Very low                    |
| Communications failure                     | Communications                     | Elect       | Unavailability of MLL voice data (radio) network   | Insignificant | Very low                    |

| <b>Risk Name</b>                                   | <b>Risk Category</b>                                  | <b>Type</b> | <b>Risk Description</b>   | <b>Rating</b> | <b>Pre-treatment Rating</b> |
|--|---|-------------|---|---------------|-----------------------------|
| Multiple 11kV circuits on single structure         | MLL Distribution Network Failure                      | Elect       | Dashwood and Seaview feeders north of Seddon, Grassmere and Richmond Brook feeders south of Seddon  | Insignificant | Low                         |
| Open point failure                                 | MLL Distribution Network Failure                      | Elect       | Failure of a switch at an open point between two feeders  | Insignificant | Some                        |
| Resource Management Act Issues                     | Resource Management Act Issues                        | Reg         | MLL is unable to progress a network expansion project due to RMA issues.  | Insignificant | Some                        |
| Site Access Control                                | Health & Safety Issues (staff and general public)     | Reg         | Situations or events in relation to the MLL electricity distribution network construction program which lead to health and safety issues for MLL staff and the general public | Insignificant | Moderate                    |
| Flooding Causing Damage to MLL Distribution Assets | Natural Environment Impact on MLL Distribution Assets | Env         | Natural environment impact on MLL distribution assets causing the unavailability of electricity supply to part or all of the Marlborough region.                              | Insignificant | Some                        |
| Multiple 11kV circuits on single structure         | MLL Distribution Network Failure                      | Elect       | Vernon and Cloudy Bay feeders around Montana  | Insignificant | Low                         |
| Communications failure                             | Communications  | Elect       | Unavailability of cell phone network  | Insignificant | Very low                    |
| Latent Material Defects                            | MLL Distribution Network Failure                      | Elect       | Material defects resulting in the inability of the MLL distribution network to safely convey electricity within the supply regulations.                                       | Insignificant | Some                        |
| Lack of Maintenance Related Network Failure        | MLL Distribution Network Failure                      | Elect       | The inability of the MLL distribution network assets to safely convey electricity within the supply regulations.  | Insignificant | Moderate                    |
| Maintenance Security Constraint at Picton Zone Sub | MLL Distribution Network Failure                      | Elect       | When one transformer is out of service there is only 1 33kV line supplying the substation due to the lack of a 33kV bus coupler   | Insignificant | Very low                    |

| <b>Risk Name</b>                        | <b>Risk Category</b>                                  | <b>Type</b> | <b>Risk Description</b>  | <b>Rating</b> | <b>Pre-treatment Rating</b> |
|---|---|-------------|--|---------------|-----------------------------|
| High Load Damage to Lines and Equipment | MLL Distribution Network Failure                      | Elect       | The inability of the MLL distribution network assets to safely convey electricity within the supply regulations. Highest risk - unescorted loads.                                    | Insignificant | Some                        |
| MLL Asset Design                        | MLL Distribution Assets Impact on Natural Environment | Env         | Poor design leading to a negative impact on the environment surrounding MLL substation assets i.e. control of SF6 gas, assets not blending into the environment, poor noise control. | Insignificant | Some                        |
| Electricity Complaints                  | Electricity Complaints                                | Reg         | Complaints resulting in reputational damage to MLL   | Insignificant | Some                        |
| Vandalism at the Blenheim GXP           | Vandalism and Public Nuisance                         | Bus         | Disruption to the operation of MLL electricity distribution network through acts of vandalism at the Blenheim GXP.   | Insignificant | Considerable                |
| Construction Site Security              | Vandalism and Public Nuisance                         | Bus         | Disruption to the operation of MLL electricity distribution network through acts of vandalism and public nuisance at network construction sites.                                     | Insignificant | Moderate                    |
| Skill Gaps                              | Knowledge Management                                  | Bus         | Skill gaps relating to the MLL asset base i.e. either equipment becomes technically obsolescent (no one can maintain it) or MLL can't attract the skills it need in the marketplace. | Insignificant | Very low                    |
| Fire Damage to Buildings and Equipment  | Fire Damage to Buildings and Equipment                | Bus         | Damage to MLL buildings and equipment (network and support infrastructure) caused by fire.   | Insignificant | Low                         |
| Chemical Spray (use and storage)        | MLL Distribution Assets Impact on Natural Environment | Env         | Major natural environment impact caused by the use of chemical sprays i.e. overspray drift, on-site mixing polluting waterways, unsafe storage or transit (fume inhalation).         | Insignificant | Moderate                    |

| <b>Risk Name</b>   | <b>Risk Category</b>                                  | <b>Type</b> | <b>Risk Description</b>   | <b>Rating</b> | <b>Pre-treatment Rating</b> |
|--|---|-------------|---|---------------|-----------------------------|
| Resource Management Act Issues                               | Resource Management Act Issues                        | Reg         | MLL is unable to progress network maintenance or upgrade work due to RMA issues.  | Insignificant | Very low                    |
| Loss of Tacit Institutional Knowledge                        | Knowledge Management                                  | Bus         | The loss of detailed background data (often uncodified) relating to the MLL asset base i.e. how to access equipment, likely fault locations, etc.   | Insignificant | Some                        |
| Data Record Unavailability                                   | Data Management and Record Access                     | Bus         | Issues relating to the availability and accuracy of MLL network data (assets and asset performance / condition).  | Insignificant | Moderate                    |
| Extended Recovery From Network Outage                        | MLL Distribution Network Access and Control Breakdown | Elect       | Longer than necessary outage, due to the breakdown of the MLL network access and control systems  | Insignificant | Moderate                    |
| Full Supply Outage - Transpower Transmission Network Failure | Transpower Transmission Network Failure               | Elect       | The inability of the Transpower transmission network assets to safely convey electricity within the supply regulations, through the loss of key equipment at the Blenheim GXP or multiple transmission line failures. | Moderate      | Considerable                |
| Full Supply Outage - Retailer Major Generation Failure       | Retailer Major Generation Failure                     | Elect       | Major generation failure causing the unavailability of electricity within the supply regulations to the Marlborough region.   | Moderate      | High                        |



## B Asset Renewal Performance Evaluation

This appendix supports the capital replacement section of the comparative performance evaluation. It sets out MLL's disclosed age profile charts under each of 51 regulatory asset categories and compares these to the age profile for the same asset category derived from combining all New Zealand electricity distribution businesses' disclosures. In these charts:

- the vertical bars are the MLL disclosed age profile (FY2013);
- the red curve is a smoothed fitting to the age profile;
- the blue dashed curve is the NZ-wide smoothed age profile; and
- the yellow vertical line is the (approximate) regulatory life.

Blank charts indicate MLL has no assets of that regulatory category.

The chart titles also give the percentages for the age disclosures where the ages are not known or where default ages are assumed. For the no-age percentages, the age profiles have been adjusted through allocation into ages in the upper quartile of the disclosed ages but high percentages of either no-age or default age values should indicate that the age profiles may be inaccurate.



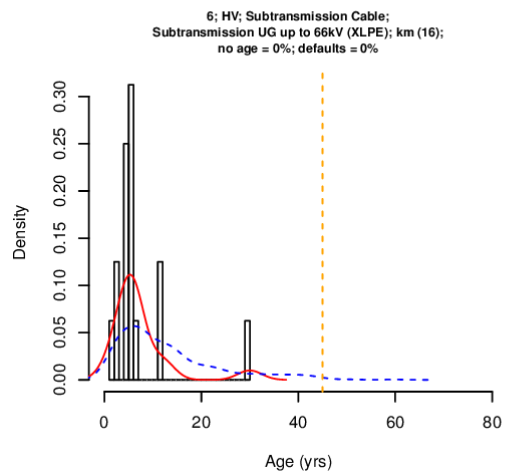
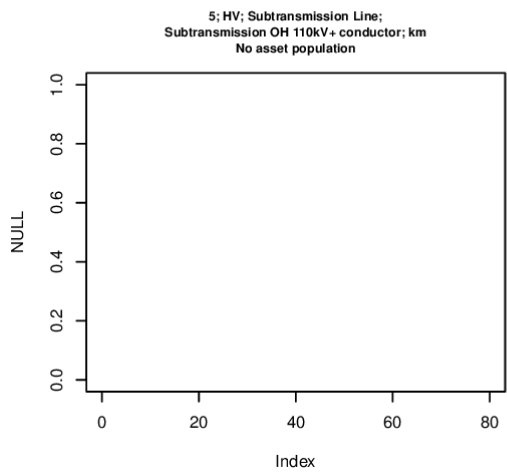
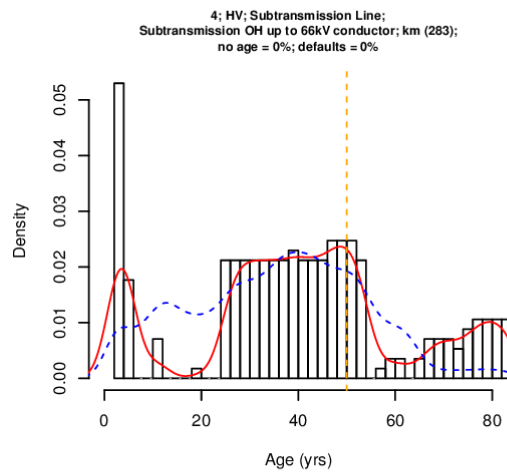
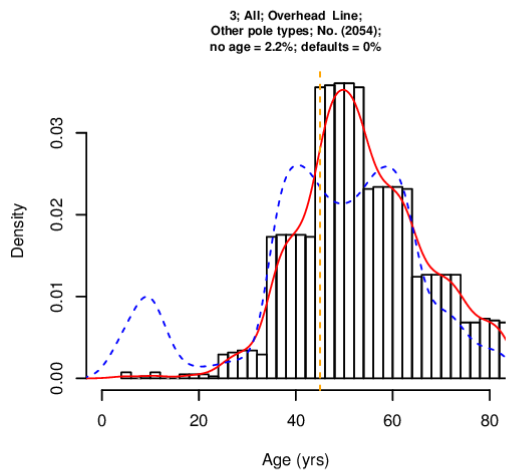
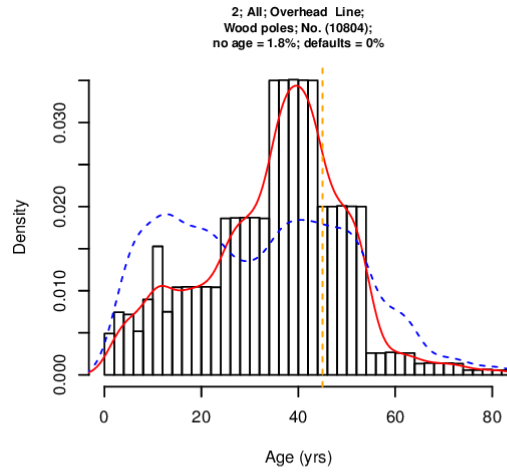
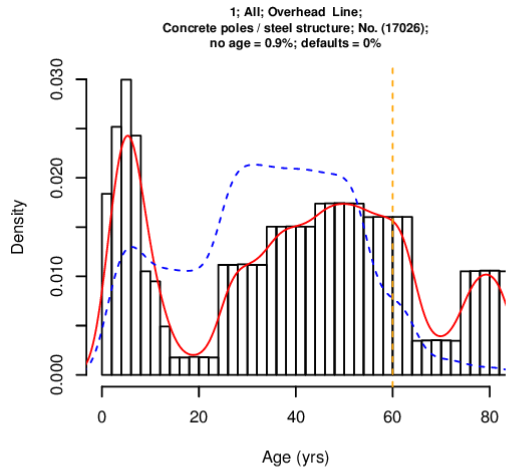

7; HV; Subtransmission Cable;  
Subtransmission UG up to 66kV (Oil pressurised); km  
No asset population

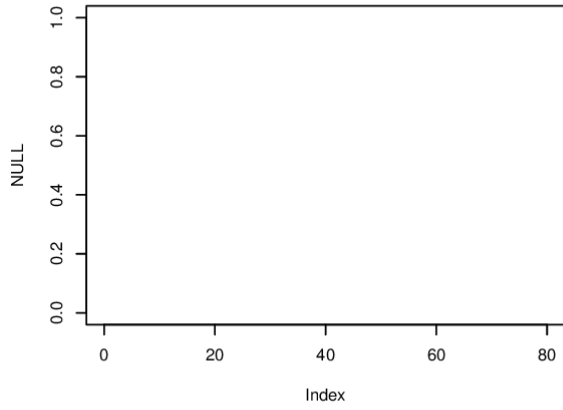

8; HV; Subtransmission Cable;  
Subtransmission UG up to 66kV (Gas pressurised); km  
No asset population

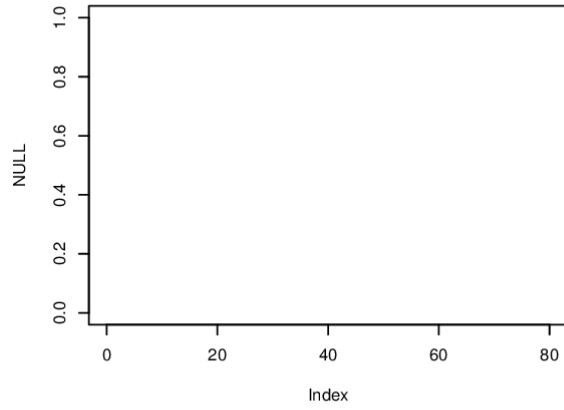

9; HV; Subtransmission Cable;  
Subtransmission UG up to 66kV (PILC); km  
No asset population

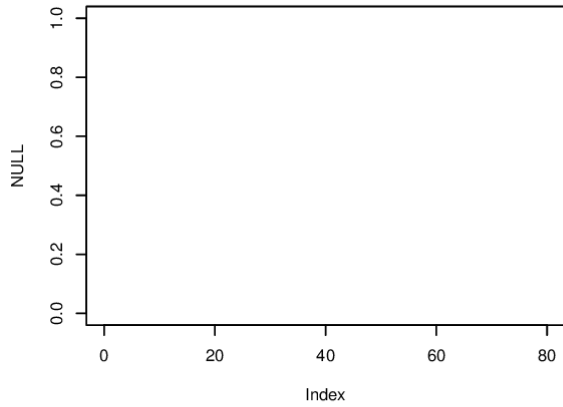

10; HV; Subtransmission Cable;  
Subtransmission UG 110kV+ (XLPE); km  
No asset population

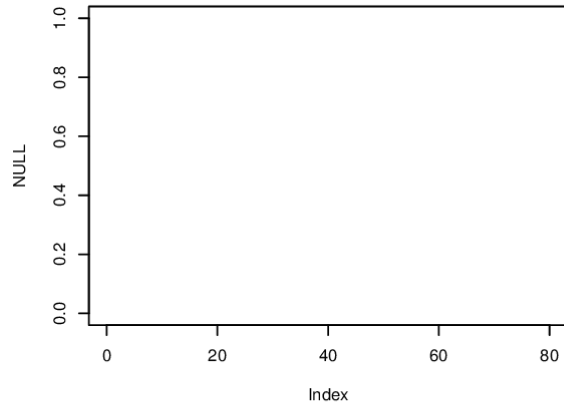

11; HV; Subtransmission Cable;  
Subtransmission UG 110kV+ (Oil pressurised); km  
No asset population

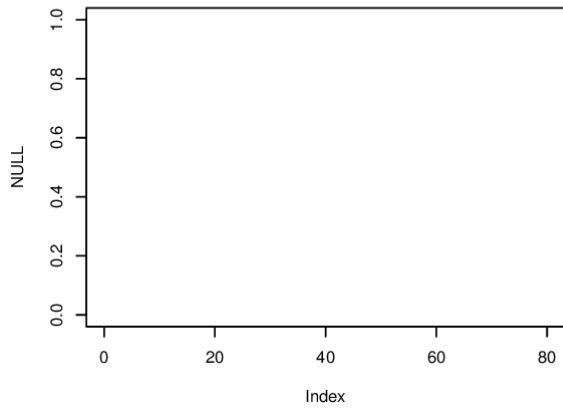

12; HV; Subtransmission Cable;  
Subtransmission UG 110kV+ (Gas Pressurised); km  
No asset population

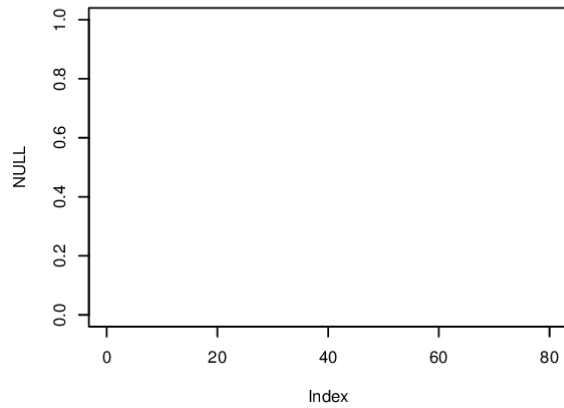

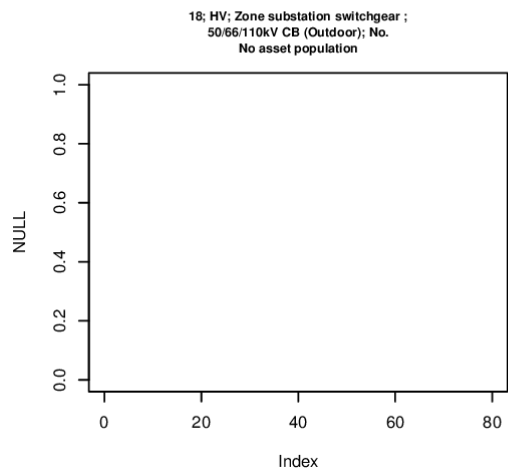
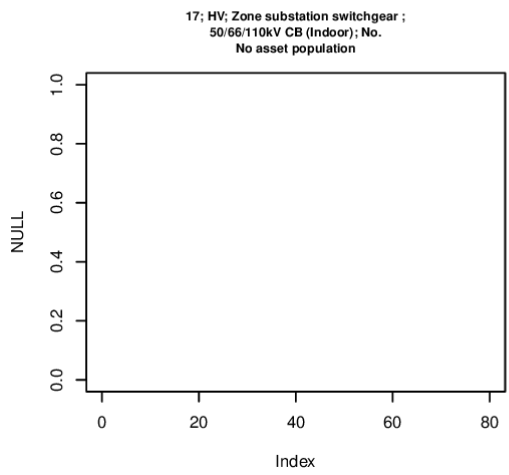
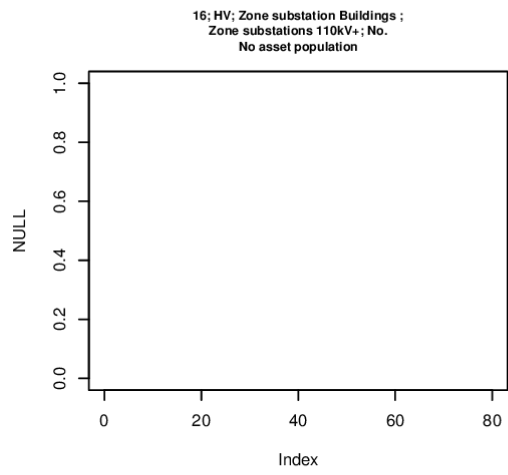
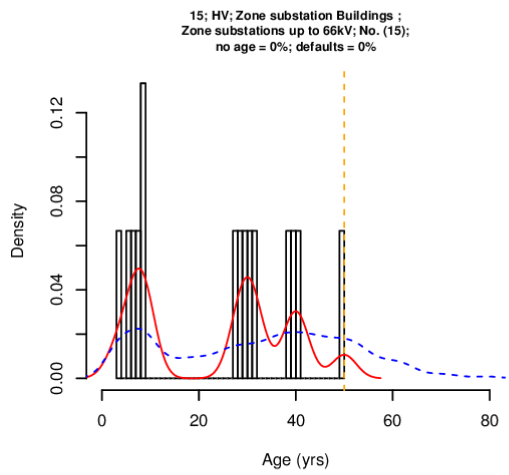
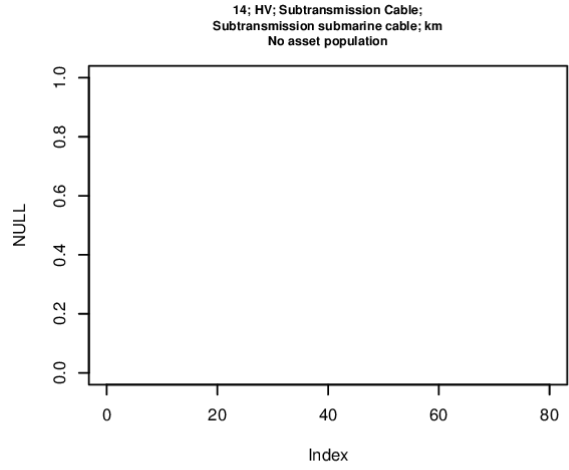
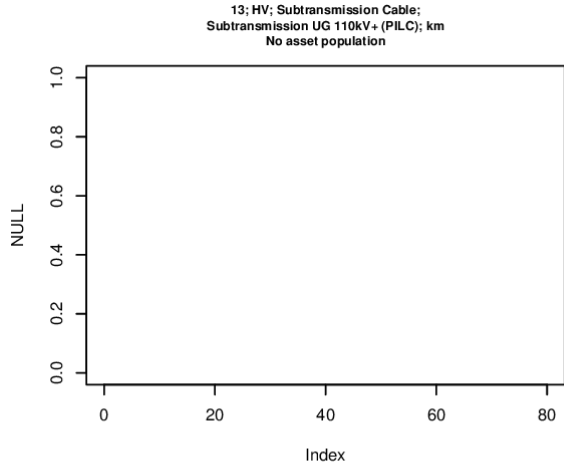

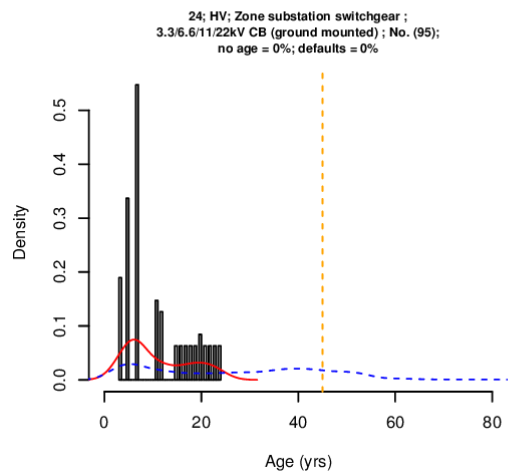
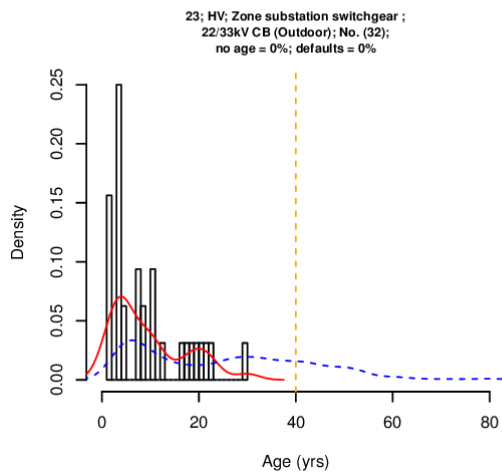
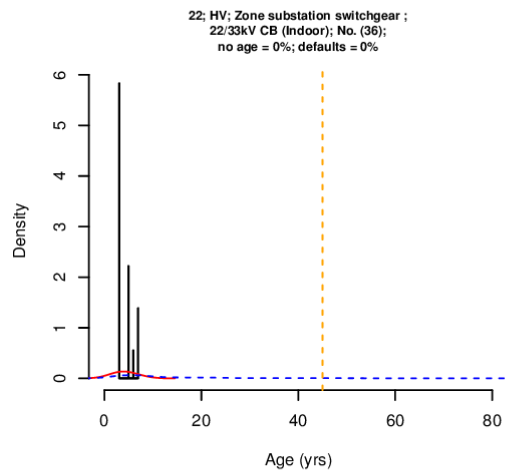
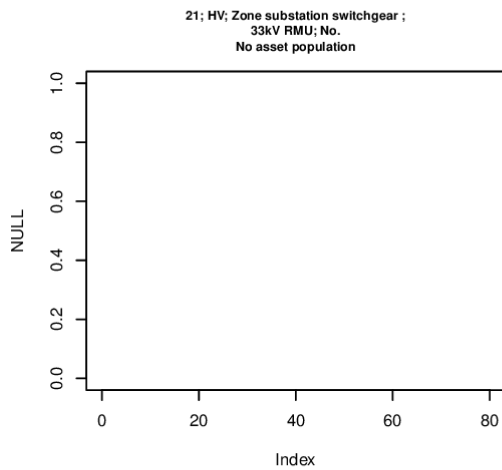
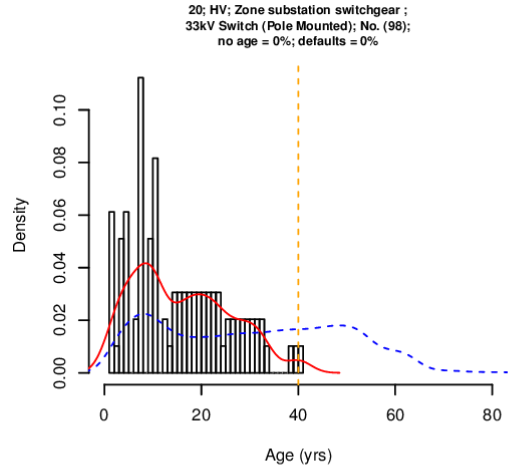
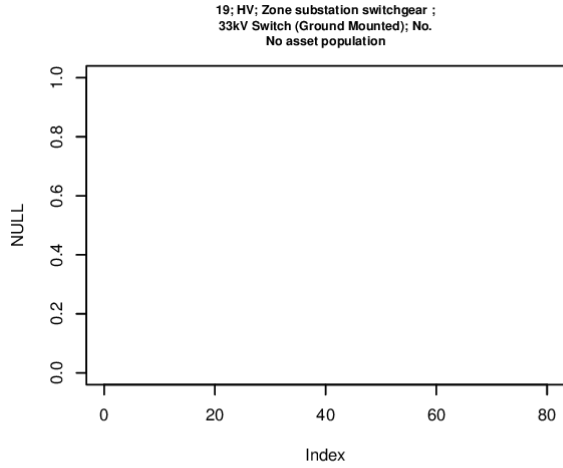

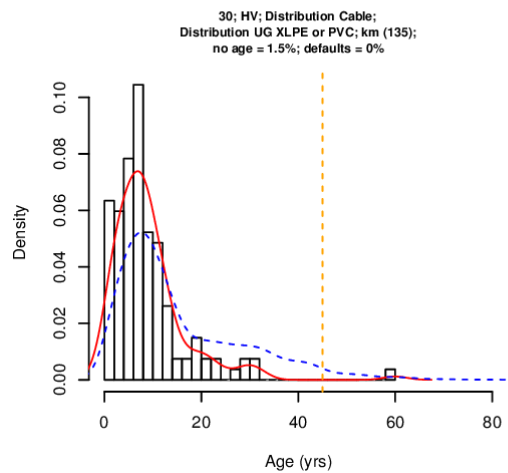
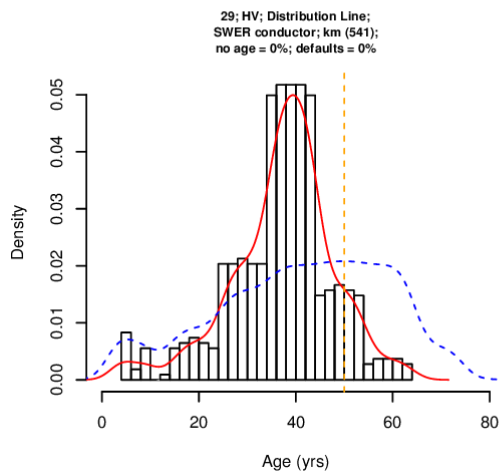
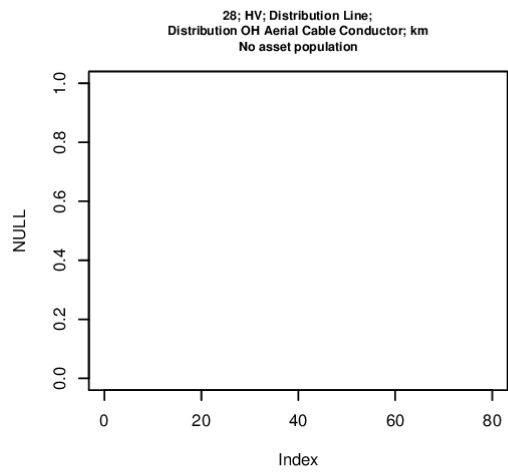
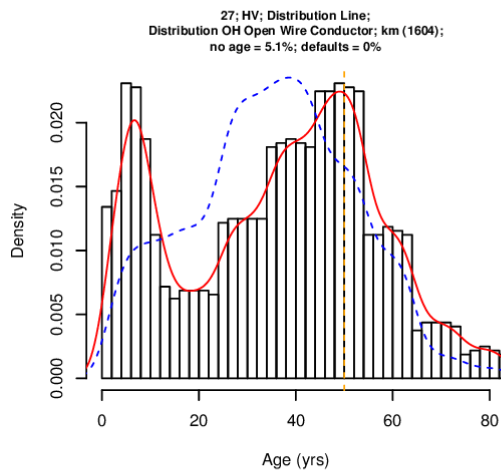
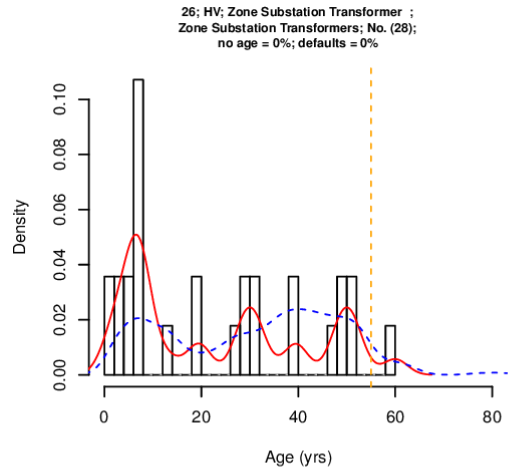
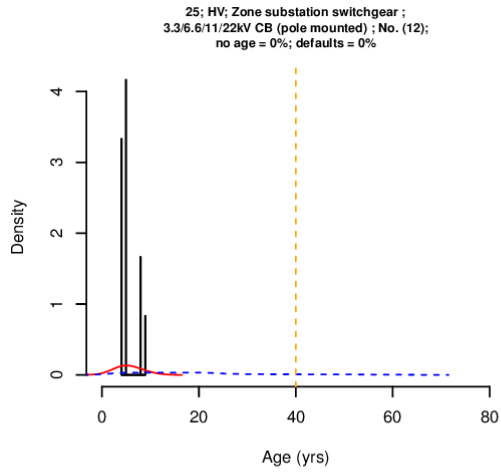

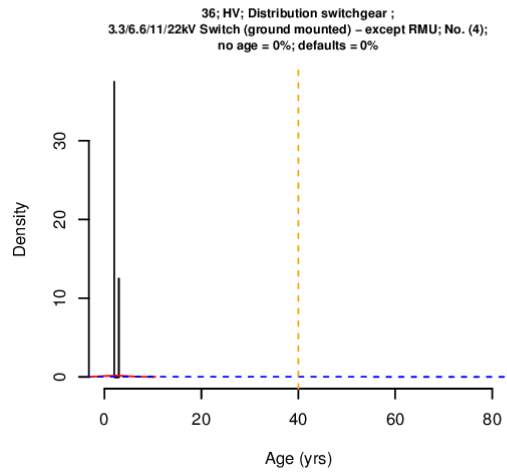
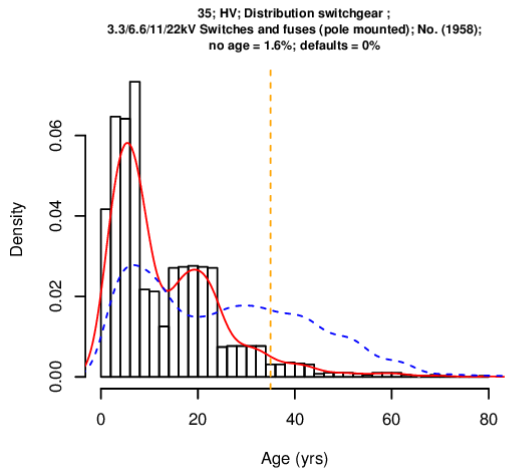
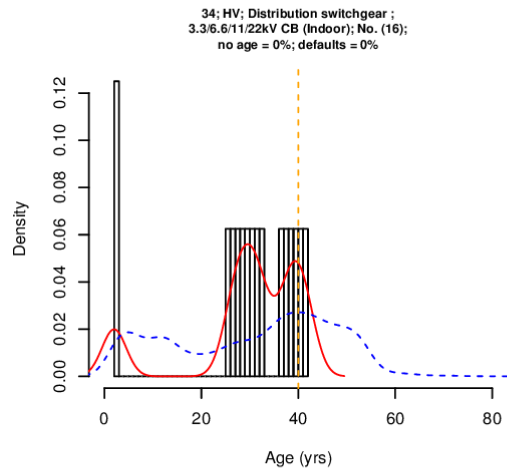
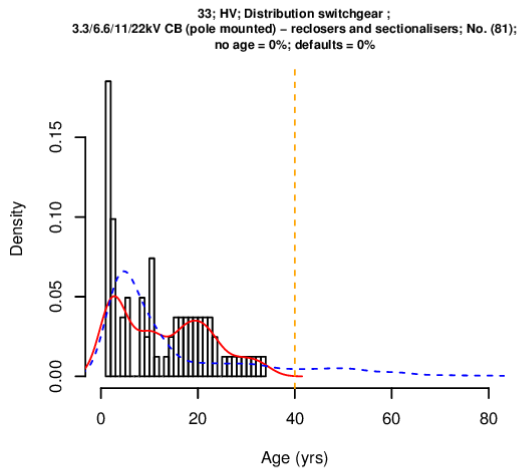
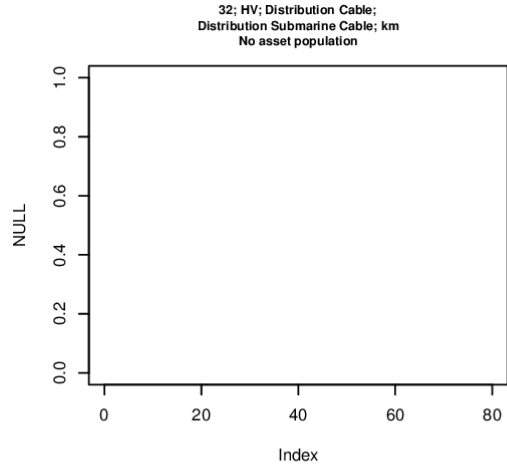
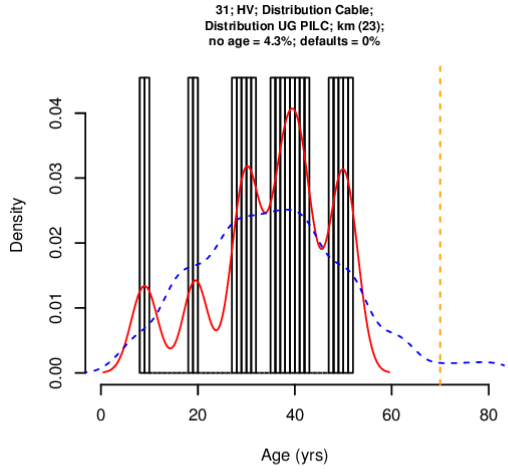

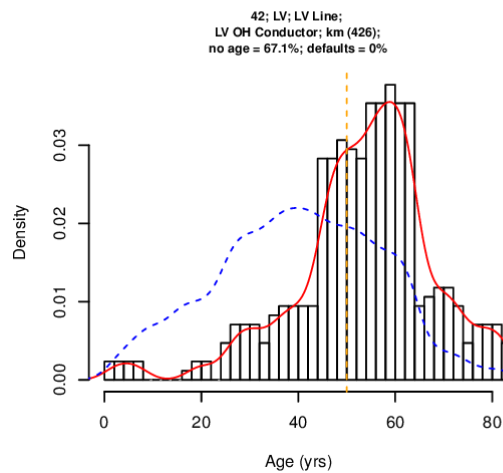
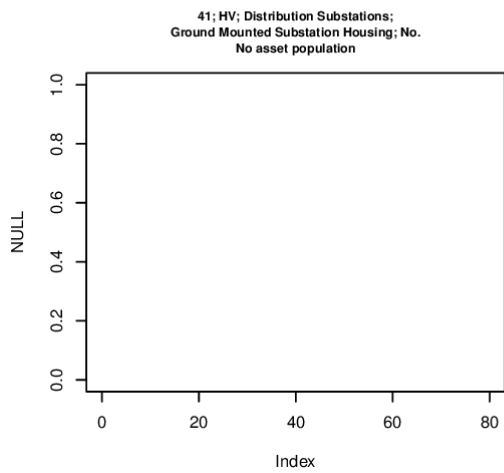
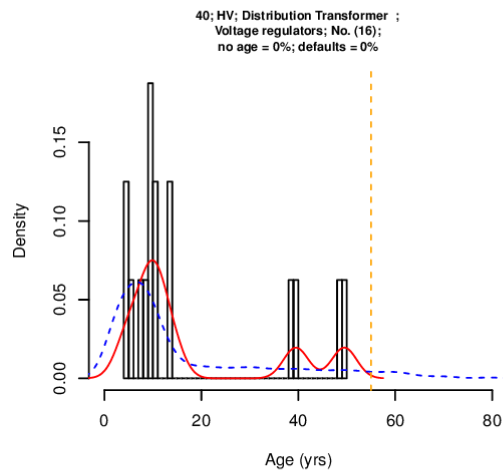
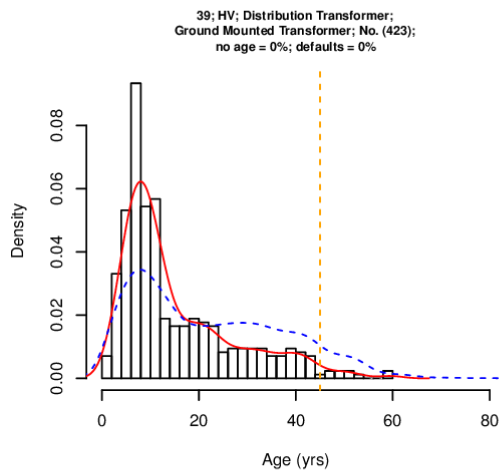
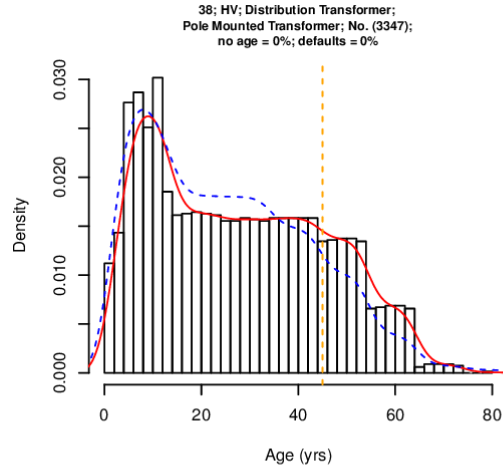
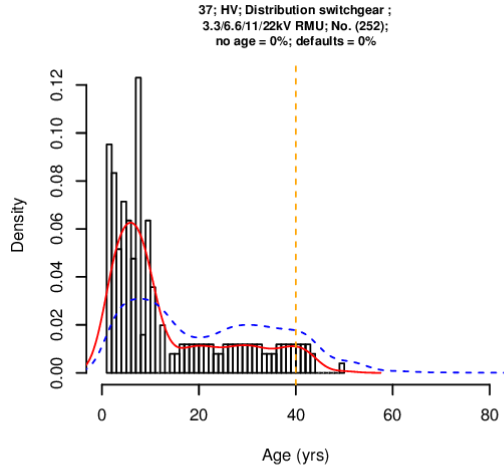

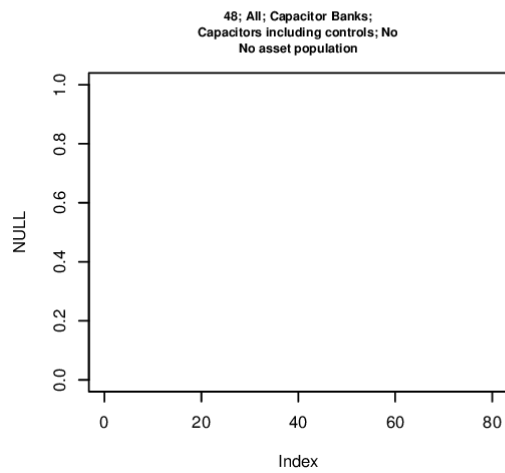
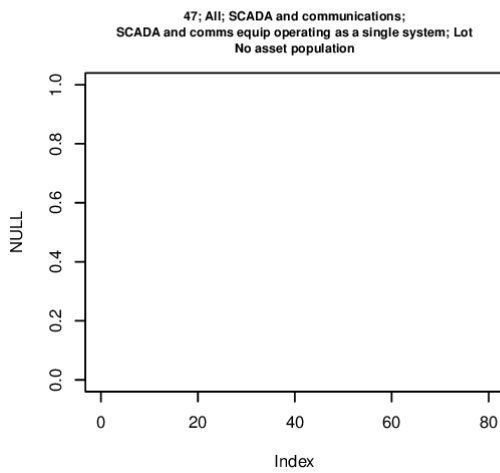
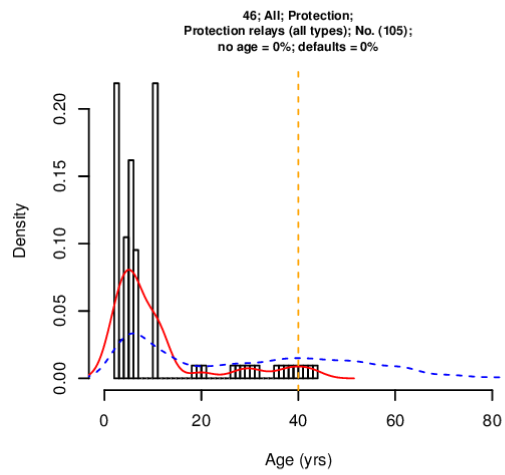
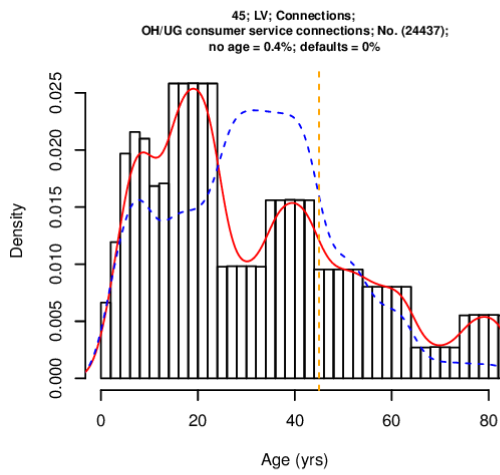
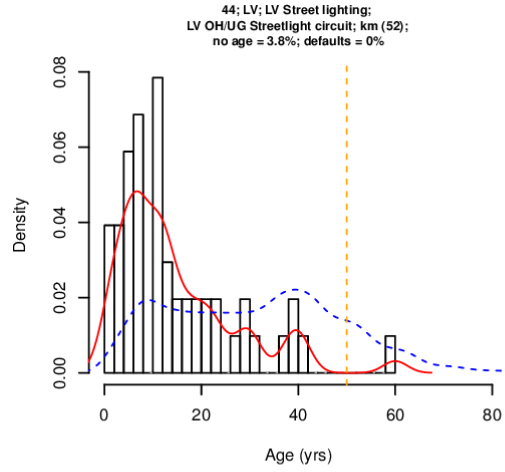
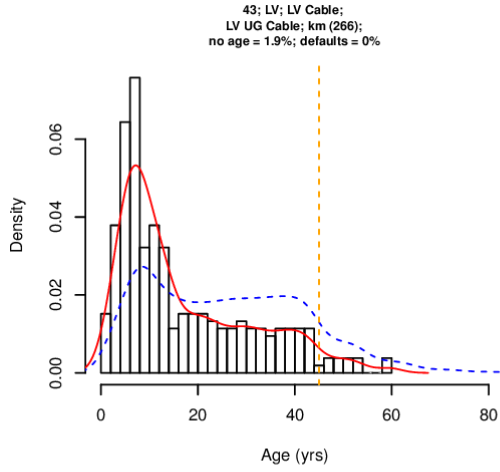



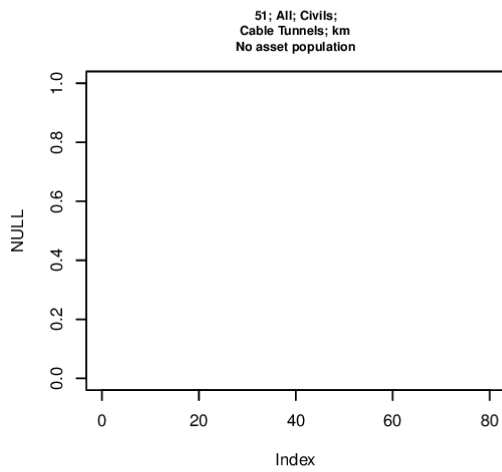
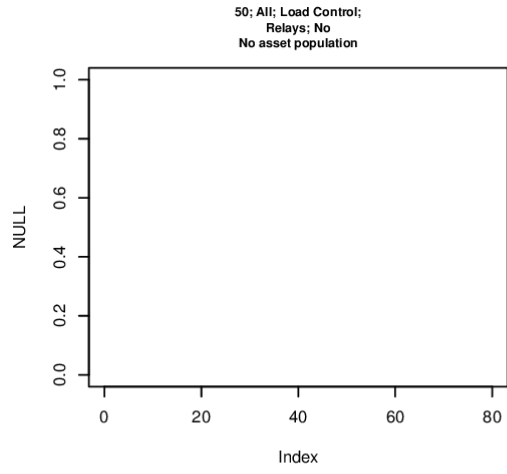
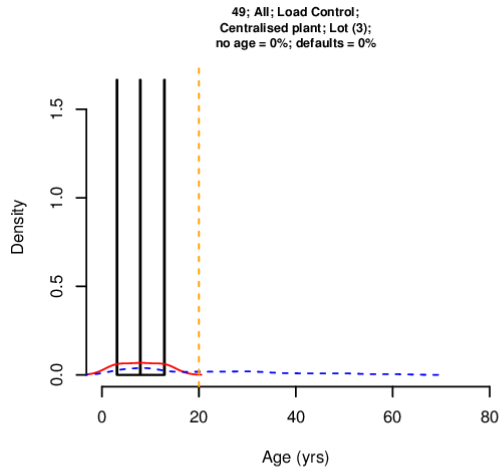

## C Disclosure Schedules

This appendix contains schedules 11 to 13 of the EDB Information Disclosure Requirements in accordance with Decision No. NZCC 22 Electricity Distribution Information Disclosure Determination 2012. Note the information in this schedule is also available as an excel spreadsheet on our website at <http://www.marlboroughlines.co.nz/About-us/Disclosures/Asset-Management.aspx>

Company Name **Marlborough Lines Ltd**  
 AMP Planning Period **1 April 2015 – 31 March 2025**

**SCHEDULE 11a: REPORT ON FORECAST CAPITAL EXPENDITURE**

This schedule requires a breakdown of forecast expenditure on assets for the current disclosure year and a 10 year planning period. The forecasts should be consistent with the supporting information set out in the AMP. The forecast is to be expressed in both constant price and nominal dollar terms. Also required is a forecast of the value of commissioned assets (i.e., the value of RAB additions)  
 EDBs must provide explanatory comment on the difference between constant price and nominal dollar forecasts of expenditure on assets in Schedule 14a (Mandatory Explanatory Notes).  
 This information is not part of audited disclosure information.

| sch ref |  | Current Year CY                   | CY+1          | CY+2          | CY+3          | CY+4          | CY+5          | CY+6          | CY+7          | CY+8          | CY+9          | CY+10         |
|---------|--|-----------------------------------|---------------|---------------|---------------|---------------|---------------|---------------|---------------|---------------|---------------|---------------|
|         |  | for year ended 31 Mar 15          | 31 Mar 16     | 31 Mar 17     | 31 Mar 18     | 31 Mar 19     | 31 Mar 20     | 31 Mar 21     | 31 Mar 22     | 31 Mar 23     | 31 Mar 24     | 31 Mar 25     |
| 7       |  |                                   |               |               |               |               |               |               |               |               |               |               |
| 8       |  |                                   |               |               |               |               |               |               |               |               |               |               |
| 9       | <b>11a(i): Expenditure on Assets Forecast</b>                            | <b>\$000 (in nominal dollars)</b> |               |               |               |               |               |               |               |               |               |               |
| 10      | Consumer connection  | 160                               | 200           | 203           | 206           | 209           | 212           | 215           | 219           | 222           | 225           | 229           |
| 11      | System growth  | 180                               | -             | -             | -             | -             | -             | 162           | 164           | 166           | 169           | 172           |
| 12      | Asset replacement and renewal  | 5,255                             | 6,155         | 6,212         | 4,378         | 6,065         | 6,501         | 6,033         | 7,217         | 7,880         | 7,998         | 8,118         |
| 13      | Asset relocations  | 205                               | 185           | 206           | 2,266         | 993           | 1,486         | 1,508         | 656           | 222           | 225           | 229           |
| 14      | Reliability, safety and environment:                                     |                                   |               |               |               |               |               |               |               |               |               |               |
| 15      | Quality of supply  | 2,250                             | 3,198         | 2,462         | 2,292         | 2,091         | 1,380         | 1,454         | 1,148         | 1,165         | 1,183         | 1,201         |
| 16      | Legislative and regulatory   | 50                                | 50            | 52            | 52            | 52            | 53            | 54            | 55            | 55            | 56            | 57            |
| 17      | Other reliability, safety and environment                                | 340                               | 220           | 917           | 690           | 779           | 791           | 1,163         | 1,093         | 555           | 563           | 572           |
| 18      | <b>Total reliability, safety and environment</b>                         | <b>2,640</b>                      | <b>3,468</b>  | <b>3,431</b>  | <b>3,034</b>  | <b>2,923</b>  | <b>2,224</b>  | <b>2,672</b>  | <b>2,296</b>  | <b>1,776</b>  | <b>1,802</b>  | <b>1,829</b>  |
| 19      | <b>Expenditure on network assets</b>                                     | <b>8,440</b>                      | <b>10,008</b> | <b>10,052</b> | <b>9,885</b>  | <b>10,190</b> | <b>10,423</b> | <b>10,590</b> | <b>10,552</b> | <b>10,266</b> | <b>10,420</b> | <b>10,576</b> |
| 20      | Non-network assets   | 3,385                             | 1,929         | 1,545         | 1,391         | 1,569         | 1,433         | 1,616         | 1,640         | 1,665         | 1,690         | 1,715         |
| 21      | <b>Expenditure on assets</b>   | <b>11,825</b>                     | <b>11,937</b> | <b>11,597</b> | <b>11,276</b> | <b>11,759</b> | <b>11,855</b> | <b>12,206</b> | <b>12,192</b> | <b>11,931</b> | <b>12,110</b> | <b>12,291</b> |
| 22      |  |                                   |               |               |               |               |               |               |               |               |               |               |
| 23      | plus Cost of financing   |                                   |               |               |               |               |               |               |               |               |               |               |
| 24      | less Value of capital contributions                                      | 100                               | 102           | 103           | 105           | 106           | 108           | 109           | 111           | 113           | 114           | 116           |
| 25      | plus Value of vested assets  |                                   |               |               |               |               |               |               |               |               |               |               |
| 26      |  |                                   |               |               |               |               |               |               |               |               |               |               |
| 27      | <b>Capital expenditure forecast</b>                                      | <b>11,725</b>                     | <b>11,835</b> | <b>11,494</b> | <b>11,171</b> | <b>11,653</b> | <b>11,748</b> | <b>12,096</b> | <b>12,081</b> | <b>11,818</b> | <b>11,995</b> | <b>12,175</b> |
| 28      |  |                                   |               |               |               |               |               |               |               |               |               |               |
| 29      | Value of commissioned assets   | 11,825                            | 11,937        | 11,597        | 11,276        | 11,759        | 11,855        | 12,206        | 12,192        | 11,931        | 12,110        | 12,291        |
| 30      |  |                                   |               |               |               |               |               |               |               |               |               |               |
| 31      |  |                                   |               |               |               |               |               |               |               |               |               |               |
| 32      |  |                                   |               |               |               |               |               |               |               |               |               |               |
| 33      |  |                                   |               |               |               |               |               |               |               |               |               |               |
| 34      |  |                                   |               |               |               |               |               |               |               |               |               |               |
| 35      |  |                                   |               |               |               |               |               |               |               |               |               |               |
| 36      |  |                                   |               |               |               |               |               |               |               |               |               |               |
| 37      | Reliability, safety and environment:                                     |                                   |               |               |               |               |               |               |               |               |               |               |
| 38      | Quality of supply  | 2,250                             | 3,198         | 2,390         | 2,225         | 2,000         | 1,300         | 1,350         | 1,050         | 1,050         | 1,050         | 1,050         |
| 39      | Legislative and regulatory   | 50                                | 50            | 50            | 50            | 50            | 50            | 50            | 50            | 50            | 50            | 50            |
| 40      | Other reliability, safety and environment                                | 340                               | 220           | 890           | 670           | 745           | 745           | 1,080         | 1,000         | 500           | 500           | 500           |
| 41      | <b>Total reliability, safety and environment</b>                         | <b>2,640</b>                      | <b>3,468</b>  | <b>3,330</b>  | <b>2,945</b>  | <b>2,795</b>  | <b>2,095</b>  | <b>2,480</b>  | <b>2,100</b>  | <b>1,600</b>  | <b>1,600</b>  | <b>1,600</b>  |
| 42      | <b>Expenditure on network assets</b>                                     | <b>8,440</b>                      | <b>10,008</b> | <b>9,760</b>  | <b>9,595</b>  | <b>9,745</b>  | <b>9,820</b>  | <b>9,830</b>  | <b>9,650</b>  | <b>9,250</b>  | <b>9,250</b>  | <b>9,250</b>  |
| 43      | Non-network assets   | 3,385                             | 1,900         | 1,500         | 1,350         | 1,500         | 1,350         | 1,500         | 1,500         | 1,500         | 1,500         | 1,500         |
| 44      | <b>Expenditure on assets</b>   | <b>11,825</b>                     | <b>11,908</b> | <b>11,260</b> | <b>10,945</b> | <b>11,245</b> | <b>11,170</b> | <b>11,330</b> | <b>11,150</b> | <b>10,750</b> | <b>10,750</b> | <b>10,750</b> |
| 45      |  |                                   |               |               |               |               |               |               |               |               |               |               |
| 46      | <b>Subcomponents of expenditure on assets (where known)</b>              |                                   |               |               |               |               |               |               |               |               |               |               |
| 47      | Energy efficiency and demand side management, reduction of energy losses |                                   |               |               |               |               |               |               |               |               |               |               |
| 48      | Overhead to underground conversion                                       |                                   |               |               |               |               |               |               |               |               |               |               |
| 49      | Research and development   |                                   |               |               |               |               |               |               |               |               |               |               |

Company Name **Marlborough Lines Ltd**  
 AMP Planning Period **1 April 2015 – 31 March 2025**

**SCHEDULE 11a: REPORT ON FORECAST CAPITAL EXPENDITURE**

This schedule requires a breakdown of forecast expenditure on assets for the current disclosure year and a 10 year planning period. The forecasts should be consistent with the supporting information set out in the AMP. The forecast is to be expressed in both constant price and nominal dollar terms. Also required is a forecast of the value of commissioned assets (i.e., the value of RAB additions). EDBs must provide explanatory comment on the difference between constant price and nominal dollar forecasts of expenditure on assets in Schedule 14a (Mandatory Explanatory Notes). This information is not part of audited disclosure information.

| sch ref |  | for year ended               |                   |                   |                   |                   |                   |                   |                   |                   |                   |                    |
|---------|--|------------------------------|-------------------|-------------------|-------------------|-------------------|-------------------|-------------------|-------------------|-------------------|-------------------|--------------------|
|         |  | Current Year CY<br>31 Mar 15 | CY+1<br>31 Mar 16 | CY+2<br>31 Mar 17 | CY+3<br>31 Mar 18 | CY+4<br>31 Mar 19 | CY+5<br>31 Mar 20 | CY+6<br>31 Mar 21 | CY+7<br>31 Mar 22 | CY+8<br>31 Mar 23 | CY+9<br>31 Mar 24 | CY+10<br>31 Mar 25 |
| 57      |  | \$000                        |                   |                   |                   |                   |                   |                   |                   |                   |                   |                    |
| 58      | <b>Difference between nominal and constant price forecasts</b> |                              |                   |                   |                   |                   |                   |                   |                   |                   |                   |                    |
| 59      | Consumer connection  | -                            | -                 | 3                 | 6                 | 9                 | 12                | 15                | 19                | 22                | 25                | 29                 |
| 60      | System growth  | -                            | -                 | -                 | -                 | -                 | -                 | 12                | 14                | 16                | 19                | 22                 |
| 61      | Asset replacement and renewal                                  | -                            | -                 | 182               | 128               | 265               | 376               | 433               | 617               | 780               | 898               | 1,018              |
| 62      | Asset relocations  | -                            | -                 | 6                 | 66                | 43                | 86                | 108               | 56                | 22                | 25                | 29                 |
| 63      | Reliability, safety and environment:                           |                              |                   |                   |                   |                   |                   |                   |                   |                   |                   |                    |
| 64      | Quality of supply  | -                            | -                 | 72                | 67                | 91                | 80                | 104               | 98                | 115               | 133               | 151                |
| 65      | Legislative and regulatory                                     | -                            | -                 | 2                 | 2                 | 2                 | 3                 | 4                 | 5                 | 5                 | 6                 | 7                  |
| 66      | Other reliability, safety and environment                      | -                            | -                 | 27                | 20                | 34                | 46                | 83                | 93                | 55                | 63                | 72                 |
| 67      | <b>Total reliability, safety and environment</b>               | -                            | -                 | 101               | 89                | 128               | 129               | 192               | 196               | 176               | 202               | 229                |
| 68      | <b>Expenditure on network assets</b>                           | -                            | -                 | 292               | 290               | 445               | 603               | 760               | 902               | 1,016             | 1,170             | 1,326              |
| 69      | Non-network assets   | -                            | 28                | 45                | 41                | 69                | 83                | 116               | 140               | 165               | 190               | 215                |
| 70      | <b>Expenditure on assets</b>                                   | -                            | 29                | 337               | 331               | 514               | 685               | 876               | 1,042             | 1,181             | 1,360             | 1,541              |
| 71      |  |                              |                   |                   |                   |                   |                   |                   |                   |                   |                   |                    |
| 72      |  |                              |                   |                   |                   |                   |                   |                   |                   |                   |                   |                    |
| 73      |  |                              |                   |                   |                   |                   |                   |                   |                   |                   |                   |                    |
| 74      | <b>11a(ii): Consumer Connection</b>                            |                              |                   |                   |                   |                   |                   |                   |                   |                   |                   |                    |
| 75      | Consumer types defined by EDB*                                 | \$000 (in constant prices)   |                   |                   |                   |                   |                   |                   |                   |                   |                   |                    |
| 76      | all  | 160                          | 200               | 200               | 200               | 200               | 200               |                   |                   |                   |                   |                    |
| 77      |  |                              |                   |                   |                   |                   |                   |                   |                   |                   |                   |                    |
| 78      |  |                              |                   |                   |                   |                   |                   |                   |                   |                   |                   |                    |
| 79      |  |                              |                   |                   |                   |                   |                   |                   |                   |                   |                   |                    |
| 80      |  |                              |                   |                   |                   |                   |                   |                   |                   |                   |                   |                    |
| 81      | *include additional rows if needed                             |                              |                   |                   |                   |                   |                   |                   |                   |                   |                   |                    |
| 82      | <b>Consumer connection expenditure</b>                         | 160                          | 200               | 200               | 200               | 200               | 200               |                   |                   |                   |                   |                    |
| 83      | less Capital contributions funding consumer connection         |                              |                   |                   |                   |                   |                   |                   |                   |                   |                   |                    |
| 84      | <b>Consumer connection less capital contributions</b>          | 160                          | 200               | 200               | 200               | 200               | 200               |                   |                   |                   |                   |                    |
| 85      | <b>11a(iii): System Growth</b>                                 |                              |                   |                   |                   |                   |                   |                   |                   |                   |                   |                    |
| 86      | Subtransmission  | 180                          |                   |                   |                   |                   |                   |                   |                   |                   |                   |                    |
| 87      | Zone substations   |                              |                   |                   |                   |                   |                   |                   |                   |                   |                   |                    |
| 88      | Distribution and LV lines                                      |                              |                   |                   |                   |                   |                   |                   |                   |                   |                   |                    |
| 89      | Distribution and LV cables                                     |                              |                   |                   |                   |                   |                   |                   |                   |                   |                   |                    |
| 90      | Distribution substations and transformers                      |                              |                   |                   |                   |                   |                   |                   |                   |                   |                   |                    |
| 91      | Distribution switchgear  |                              |                   |                   |                   |                   |                   |                   |                   |                   |                   |                    |
| 92      | Other network assets   |                              |                   |                   |                   |                   |                   |                   |                   |                   |                   |                    |
| 93      | <b>System growth expenditure</b>                               | 180                          | -                 | -                 | -                 | -                 | -                 | -                 | -                 | -                 | -                 | -                  |
| 94      | less Capital contributions funding system growth               |                              |                   |                   |                   |                   |                   |                   |                   |                   |                   |                    |
| 95      | <b>System growth less capital contributions</b>                | 180                          | -                 | -                 | -                 | -                 | -                 | -                 | -                 | -                 | -                 | -                  |

Company Name **Marlborough Lines Ltd**  
 AMP Planning Period **1 April 2015 – 31 March 2025**

**SCHEDULE 11a: REPORT ON FORECAST CAPITAL EXPENDITURE**

This schedule requires a breakdown of forecast expenditure on assets for the current disclosure year and a 10 year planning period. The forecasts should be consistent with the supporting information set out in the AMP. The forecast is to be expressed in both constant price and nominal dollar terms. Also required is a forecast of the value of commissioned assets (i.e., the value of RAB additions)  
 EDBs must provide explanatory comment on the difference between constant price and nominal dollar forecasts of expenditure on assets in Schedule 14a (Mandatory Explanatory Notes).  
 This information is not part of audited disclosure information.

sch ref

|  | Current Year CY                   | CY+1         | CY+2         | CY+3         | CY+4         | CY+5         |
|--|-----------------------------------|--------------|--------------|--------------|--------------|--------------|
| for year ended   | 31 Mar 15                         | 31 Mar 16    | 31 Mar 17    | 31 Mar 18    | 31 Mar 19    | 31 Mar 20    |
| <b>11a(iv): Asset Replacement and Renewal</b>                    | <b>\$000 (in constant prices)</b> |              |              |              |              |              |
| Subtransmission  | 1,500                             | 1,475        | 800          | 1,500        | 600          | 600          |
| Zone substations   | 75                                | 1,100        | 100          | 600          | 950          | 900          |
| Distribution and LV lines  | 3,000                             | 2,575        | 3,235        | 1,575        | 2,650        | 2,775        |
| Distribution and LV cables                                       | 280                               | 50           | 600          | 100          | 750          | 450          |
| Distribution substations and transformers                        | 400                               | 475          | 875          | 75           | 400          | 575          |
| Distribution switchgear  |                                   | 480          | 420          | 400          | 450          | 825          |
| Other network assets   |                                   |              |              |              |              |              |
| <b>Asset replacement and renewal expenditure</b>                 | <b>5,255</b>                      | <b>6,155</b> | <b>6,030</b> | <b>4,250</b> | <b>5,800</b> | <b>6,125</b> |
| less Capital contributions funding asset replacement and renewal |                                   |              |              |              |              |              |
| <b>Asset replacement and renewal less capital contributions</b>  | <b>5,255</b>                      | <b>6,155</b> | <b>6,030</b> | <b>4,250</b> | <b>5,800</b> | <b>6,125</b> |
| <b>11a(v):Asset Relocations</b>                                  |                                   |              |              |              |              |              |
| <i>Project or programme*</i>                                     |                                   |              |              |              |              |              |
| Underground conversions  | 125                               | 150          | 200          | 2,200        | 950          | 1,400        |
| Roading Authority Relocations                                    | -                                 | -            | -            | -            | -            | -            |
| Forestry Relocations   | 80                                | -            | -            | -            | -            | -            |
| Other relocations  |                                   | 35           |              |              |              |              |
| <i>*include additional rows if needed</i>                        |                                   |              |              |              |              |              |
| All other asset relocations projects or programmes               |                                   |              |              |              |              |              |
| <b>Asset relocations expenditure</b>                             | <b>205</b>                        | <b>185</b>   | <b>200</b>   | <b>2,200</b> | <b>950</b>   | <b>1,400</b> |
| less Capital contributions funding asset relocations             |                                   |              |              |              |              |              |
| <b>Asset relocations less capital contributions</b>              | <b>205</b>                        | <b>185</b>   | <b>200</b>   | <b>2,200</b> | <b>950</b>   | <b>1,400</b> |
| <b>11a(vi):Quality of Supply</b>                                 |                                   |              |              |              |              |              |
| <i>Project or programme*</i>                                     |                                   |              |              |              |              |              |
| SCADA  | 250                               | 340          | 340          | 200          | 200          | 200          |
| Network Automation   | 1,250                             | 1,098        | 1,000        | 1,275        | 1,250        | 800          |
| Digital Radio Network  | 700                               | 650          | 650          | 250          | -            | -            |
| Alternative Supplies   |                                   | 1,110        | 400          | 500          | 550          | 300          |
| Generators   | 50                                | -            | -            | -            | -            | -            |
| <i>*include additional rows if needed</i>                        |                                   |              |              |              |              |              |
| All other quality of supply projects or programmes               |                                   |              |              |              |              |              |
| <b>Quality of supply expenditure</b>                             | <b>2,250</b>                      | <b>3,198</b> | <b>2,390</b> | <b>2,225</b> | <b>2,000</b> | <b>1,300</b> |
| less Capital contributions funding quality of supply             |                                   |              |              |              |              |              |
| <b>Quality of supply less capital contributions</b>              | <b>2,250</b>                      | <b>3,198</b> | <b>2,390</b> | <b>2,225</b> | <b>2,000</b> | <b>1,300</b> |
| <b>11a(vii): Legislative and Regulatory</b>                      |                                   |              |              |              |              |              |
| <i>Project or programme*</i>                                     |                                   |              |              |              |              |              |
| General  | 50                                | 50           | 50           | 50           | 50           | 50           |
|  |                                   |              |              |              |              |              |
|  |                                   |              |              |              |              |              |
|  |                                   |              |              |              |              |              |
| <i>*include additional rows if needed</i>                        |                                   |              |              |              |              |              |
| All other legislative and regulatory projects or programmes      |                                   |              |              |              |              |              |
| <b>Legislative and regulatory expenditure</b>                    | <b>50</b>                         | <b>50</b>    | <b>50</b>    | <b>50</b>    | <b>50</b>    | <b>50</b>    |
| less Capital contributions funding legislative and regulatory    |                                   |              |              |              |              |              |
| <b>Legislative and regulatory less capital contributions</b>     | <b>50</b>                         | <b>50</b>    | <b>50</b>    | <b>50</b>    | <b>50</b>    | <b>50</b>    |

Company Name **Marlborough Lines Ltd**  
 AMP Planning Period **1 April 2015 – 31 March 2025**

**SCHEDULE 11a: REPORT ON FORECAST CAPITAL EXPENDITURE**

This schedule requires a breakdown of forecast expenditure on assets for the current disclosure year and a 10 year planning period. The forecasts should be consistent with the supporting information set out in the AMP. The forecast is to be expressed in both constant price and nominal dollar terms. Also required is a forecast of the value of commissioned assets (i.e., the value of RAB additions)  
 EDBs must provide explanatory comment on the difference between constant price and nominal dollar forecasts of expenditure on assets in Schedule 14a (Mandatory Explanatory Notes).  
 This information is not part of audited disclosure information.

sch ref

161  
162  
163  
164  
165  
166  
167  
168  
169  
170  
171  
172  
173  
174  
175  
176  
177  
178  
179  
180  
181  
182  
183  
184  
185  
186  
187  
188  
189  
190  
191  
192  
193  
194  
195  
196  
197  
198  
199  
200

Current Year CY  
for year ended **31 Mar 15** **31 Mar 16** **31 Mar 17** **31 Mar 18** **31 Mar 19** **31 Mar 20**

**11a(viii): Other Reliability, Safety and Environment**

| Project or programme*  | 5000 (in constant prices) |            |            |            |            |            |
|--|---------------------------|------------|------------|------------|------------|------------|
| Earthing (NERs and Resonant)   | 250                       | -          | 500        | 450        | 500        | 500        |
| Tee Joint Removal  | 90                        | 100        | 150        | 100        | 125        | 125        |
| SWER Reinsulation  |                           | 120        | 240        | 120        | 120        | 120        |
|  |                           |            |            |            |            |            |
|  |                           |            |            |            |            |            |
| <b>Other reliability, safety and environment expenditure</b>                 | <b>340</b>                | <b>220</b> | <b>890</b> | <b>670</b> | <b>745</b> | <b>745</b> |
| less Capital contributions funding other reliability, safety and environment |                           |            |            |            |            |            |
| <b>Other reliability, safety and environment less capital contributions</b>  | <b>340</b>                | <b>220</b> | <b>890</b> | <b>670</b> | <b>745</b> | <b>745</b> |

**11a(ix): Non-Network Assets**

| Routine expenditure                   |                           |              |              |              |              |              |
|---------------------------------------|---------------------------|--------------|--------------|--------------|--------------|--------------|
| Project or programme*                 | 5000 (in constant prices) |              |              |              |              |              |
| Test Equipment                        | 210                       | 50           | 50           | 50           | 50           | 50           |
| Plant and Tools                       | 440                       | 280          | 250          | 300          | 250          | 300          |
| Vehicles                              | 1,250                     | 240          | 500          | 250          | 500          | 250          |
| Land, Buildings and office equipment  | 435                       | 110          | 300          | 350          | 300          | 350          |
| IT Computers                          | 1,050                     | 820          | 400          | 400          | 400          | 400          |
|                                       |                           |              |              |              |              |              |
|                                       |                           |              |              |              |              |              |
| <b>Routine expenditure</b>            | <b>3,385</b>              | <b>1,500</b> | <b>1,500</b> | <b>1,350</b> | <b>1,500</b> | <b>1,350</b> |
| Atypical expenditure                  |                           |              |              |              |              |              |
| Project or programme*                 | 5000 (in constant prices) |              |              |              |              |              |
| Building Earthquake resilience        |                           | 400          |              |              |              |              |
|                                       |                           |              |              |              |              |              |
|                                       |                           |              |              |              |              |              |
|                                       |                           |              |              |              |              |              |
| <b>Atypical expenditure</b>           | <b>-</b>                  | <b>400</b>   | <b>-</b>     | <b>-</b>     | <b>-</b>     | <b>-</b>     |
| <b>Non-network assets expenditure</b> | <b>3,385</b>              | <b>1,900</b> | <b>1,500</b> | <b>1,350</b> | <b>1,500</b> | <b>1,350</b> |

Company Name **Marlborough Lines Ltd**  
 AMP Planning Period **1 April 2015 – 31 March 2025**

**SCHEDULE 11b: REPORT ON FORECAST OPERATIONAL EXPENDITURE**

This schedule requires a breakdown of forecast operational expenditure for the disclosure year and a 10 year planning period. The forecasts should be consistent with the supporting information set out in the AMP. The forecast is to be expressed in both constant price and nominal dollar terms. EDBs must provide explanatory comment on the difference between constant price and nominal dollar operational expenditure forecasts in Schedule 14a (Mandatory Explanatory Notes). This information is not part of audited disclosure information.

sch ref

|   | Current Year CY                   | CY+1          | CY+2          | CY+3          | CY+4          | CY+5          | CY+6          | CY+7          | CY+8          | CY+9          | CY+10         |
|---|-----------------------------------|---------------|---------------|---------------|---------------|---------------|---------------|---------------|---------------|---------------|---------------|
| for year ended                                    | 31 Mar 15                         | 31 Mar 16     | 31 Mar 17     | 31 Mar 18     | 31 Mar 19     | 31 Mar 20     | 31 Mar 21     | 31 Mar 22     | 31 Mar 23     | 31 Mar 24     | 31 Mar 25     |
| <b>Operational Expenditure Forecast</b>           |                                   |               |               |               |               |               |               |               |               |               |               |
|   | <b>\$000 (in nominal dollars)</b> |               |               |               |               |               |               |               |               |               |               |
| Service interruptions and emergencies             | 900                               | 914           | 927           | 941           | 955           | 970           | 984           | 999           | 1,014         | 1,029         | 1,044         |
| Vegetation management                             | 2,140                             | 2,456         | 2,493         | 2,531         | 2,568         | 2,607         | 2,646         | 2,686         | 2,726         | 2,767         | 2,809         |
| Routine and corrective maintenance and inspection | 2,650                             | 2,741         | 2,782         | 2,823         | 2,866         | 2,909         | 2,952         | 2,997         | 3,042         | 3,087         | 3,133         |
| Asset replacement and renewal                     | 210                               | 218           | 221           | 225           | 228           | 232           | 235           | 239           | 242           | 246           | 250           |
| <b>Network Opex</b>                               | <b>5,900</b>                      | <b>6,329</b>  | <b>6,423</b>  | <b>6,520</b>  | <b>6,618</b>  | <b>6,717</b>  | <b>6,818</b>  | <b>6,920</b>  | <b>7,024</b>  | <b>7,129</b>  | <b>7,236</b>  |
| System operations and network support             | 1,900                             | 1,954         | 1,983         | 2,013         | 2,043         | 2,074         | 2,105         | 2,136         | 2,168         | 2,201         | 2,234         |
| Business support                                  | 3,500                             | 3,553         | 3,606         | 3,660         | 3,715         | 3,770         | 3,827         | 3,884         | 3,943         | 4,002         | 4,062         |
| <b>Non-network opex</b>                           | <b>5,400</b>                      | <b>5,506</b>  | <b>5,589</b>  | <b>5,673</b>  | <b>5,758</b>  | <b>5,844</b>  | <b>5,932</b>  | <b>6,021</b>  | <b>6,111</b>  | <b>6,203</b>  | <b>6,296</b>  |
| <b>Operational expenditure</b>                    | <b>11,300</b>                     | <b>11,835</b> | <b>12,012</b> | <b>12,193</b> | <b>12,375</b> | <b>12,561</b> | <b>12,750</b> | <b>12,941</b> | <b>13,135</b> | <b>13,332</b> | <b>13,532</b> |

|   | Current Year CY | CY+1          | CY+2          | CY+3          | CY+4          | CY+5          | CY+6          | CY+7          | CY+8          | CY+9          | CY+10         |
|---|-----------------|---------------|---------------|---------------|---------------|---------------|---------------|---------------|---------------|---------------|---------------|
| for year ended                                    | 31 Mar 15       | 31 Mar 16     | 31 Mar 17     | 31 Mar 18     | 31 Mar 19     | 31 Mar 20     | 31 Mar 21     | 31 Mar 22     | 31 Mar 23     | 31 Mar 24     | 31 Mar 25     |
| <b>\$000 (in constant prices)</b>                 |                 |               |               |               |               |               |               |               |               |               |               |
| Service interruptions and emergencies             | 900             | 900           | 900           | 900           | 900           | 900           | 900           | 900           | 900           | 900           | 900           |
| Vegetation management                             | 2,140           | 2,420         | 2,420         | 2,420         | 2,420         | 2,420         | 2,420         | 2,420         | 2,420         | 2,420         | 2,420         |
| Routine and corrective maintenance and inspection | 2,650           | 2,700         | 2,700         | 2,700         | 2,700         | 2,700         | 2,700         | 2,700         | 2,700         | 2,700         | 2,700         |
| Asset replacement and renewal                     | 210             | 215           | 215           | 215           | 215           | 215           | 215           | 215           | 215           | 215           | 215           |
| <b>Network Opex</b>                               | <b>5,900</b>    | <b>6,235</b>  | <b>6,235</b>  | <b>6,235</b>  | <b>6,235</b>  | <b>6,235</b>  | <b>6,235</b>  | <b>6,235</b>  | <b>6,235</b>  | <b>6,235</b>  | <b>6,235</b>  |
| System operations and network support             | 1,900           | 1,925         | 1,925         | 1,925         | 1,925         | 1,925         | 1,925         | 1,925         | 1,925         | 1,925         | 1,925         |
| Business support                                  | 3,500           | 3,500         | 3,500         | 3,500         | 3,500         | 3,500         | 3,500         | 3,500         | 3,500         | 3,500         | 3,500         |
| <b>Non-network opex</b>                           | <b>5,400</b>    | <b>5,425</b>  | <b>5,425</b>  | <b>5,425</b>  | <b>5,425</b>  | <b>5,425</b>  | <b>5,425</b>  | <b>5,425</b>  | <b>5,425</b>  | <b>5,425</b>  | <b>5,425</b>  |
| <b>Operational expenditure</b>                    | <b>11,300</b>   | <b>11,660</b> | <b>11,660</b> | <b>11,660</b> | <b>11,660</b> | <b>11,660</b> | <b>11,660</b> | <b>11,660</b> | <b>11,660</b> | <b>11,660</b> | <b>11,660</b> |

**Subcomponents of operational expenditure (where known)**

|  |     |     |     |     |     |     |     |     |     |     |     |
|--|-----|-----|-----|-----|-----|-----|-----|-----|-----|-----|-----|
| Energy efficiency and demand side management, reduction of energy losses |     |     |     |     |     |     |     |     |     |     |     |
| Direct billing*  |     |     |     |     |     |     |     |     |     |     |     |
| Research and Development   |     |     |     |     |     |     |     |     |     |     |     |
| Insurance  | 230 | 230 | 230 | 230 | 230 | 230 | 230 | 230 | 230 | 230 | 230 |

\* Direct billing expenditure by suppliers that direct bill the majority of their consumers

|  | Current Year CY | CY+1       | CY+2       | CY+3       | CY+4       | CY+5       | CY+6         | CY+7         | CY+8         | CY+9         | CY+10        |
|--|-----------------|------------|------------|------------|------------|------------|--------------|--------------|--------------|--------------|--------------|
| for year ended                                       | 31 Mar 15       | 31 Mar 16  | 31 Mar 17  | 31 Mar 18  | 31 Mar 19  | 31 Mar 20  | 31 Mar 21    | 31 Mar 22    | 31 Mar 23    | 31 Mar 24    | 31 Mar 25    |
| <b>Difference between nominal and real forecasts</b> |                 |            |            |            |            |            |              |              |              |              |              |
|  | <b>\$000</b>    |            |            |            |            |            |              |              |              |              |              |
| Service interruptions and emergencies                | -               | 13         | 27         | 41         | 55         | 70         | 84           | 99           | 114          | 129          | 144          |
| Vegetation management                                | -               | 36         | 73         | 111        | 148        | 187        | 226          | 266          | 306          | 347          | 389          |
| Routine and corrective maintenance and inspection    | -               | 40         | 82         | 123        | 166        | 209        | 252          | 297          | 342          | 387          | 433          |
| Asset replacement and renewal                        | -               | 3          | 6          | 10         | 13         | 17         | 20           | 24           | 27           | 31           | 35           |
| <b>Network Opex</b>                                  | <b>-</b>        | <b>94</b>  | <b>188</b> | <b>285</b> | <b>383</b> | <b>482</b> | <b>583</b>   | <b>685</b>   | <b>789</b>   | <b>894</b>   | <b>1,001</b> |
| System operations and network support                | -               | 29         | 58         | 88         | 118        | 149        | 180          | 211          | 243          | 276          | 309          |
| Business support                                     | -               | 52         | 106        | 160        | 215        | 270        | 327          | 384          | 443          | 502          | 562          |
| <b>Non-network opex</b>                              | <b>-</b>        | <b>81</b>  | <b>164</b> | <b>248</b> | <b>333</b> | <b>419</b> | <b>507</b>   | <b>596</b>   | <b>686</b>   | <b>778</b>   | <b>871</b>   |
| <b>Operational expenditure</b>                       | <b>-</b>        | <b>175</b> | <b>352</b> | <b>533</b> | <b>715</b> | <b>901</b> | <b>1,090</b> | <b>1,281</b> | <b>1,475</b> | <b>1,672</b> | <b>1,872</b> |

Company Name **Marlborough Lines Ltd**  
 AMP Planning Period **1 April 2015 – 31 March 2025**

**SCHEDULE 12a: REPORT ON ASSET CONDITION**

This schedule requires a breakdown of asset condition by asset class as at the start of the forecast year. The data accuracy assessment relates to the percentage values disclosed in the asset condition columns. Also required is a forecast of the percentage of units to be replaced in the next 5 years. All information should be consistent with the information provided in the AMP and the expenditure on assets forecast in Schedule 11a. All units relating to cable and line assets, that are expressed in km, refer to circuit lengths.

sch ref

| Asset condition at start of planning period (percentage of units by grade) |                |                            |   |         |         |         |         |               |                     |  |        |
|--|----------------|----------------------------|---|---------|---------|---------|---------|---------------|---------------------|--|--------|
| Voltage  | Asset category | Asset class                | Units   | Grade 1 | Grade 2 | Grade 3 | Grade 4 | Grade unknown | Data accuracy (1-4) | % of asset forecast to be replaced in next 5 years |        |
|  | All            | Overhead Line              | Concrete poles / steel structure                | No.     | 0.01%   | 0.74%   | 77.63%  | 12.83%        | 8.79%               | 3  | 2.00%  |
|  | All            | Overhead Line              | Wood poles                                      | No.     | 0.20%   | 2.60%   | 85.91%  | 4.99%         | 6.30%               | 3  | 10.00% |
|  | All            | Overhead Line              | Other pole types                                | No.     | 0.16%   | 2.76%   | 74.98%  | 0.70%         | 21.40%              | 2  | 10.00% |
|  | HV             | Subtransmission Line       | Subtransmission OH up to 66kV conductor         | km      |         | 0.10%   | 89.15%  | 10.75%        |                     | 3  |        |
|  | HV             | Subtransmission Line       | Subtransmission OH 110kV+ conductor             | km      |         |         |         |               | N/A                 |  |        |
|  | HV             | Subtransmission Cable      | Subtransmission UG up to 66kV (XLPE)            | km      |         |         | 92.20%  | 7.80%         |                     | 3  |        |
|  | HV             | Subtransmission Cable      | Subtransmission UG up to 66kV (Oil pressurised) | km      |         |         |         |               | N/A                 |  |        |
|  | HV             | Subtransmission Cable      | Subtransmission UG up to 66kV (Gas pressurised) | km      |         |         |         |               | N/A                 |  |        |
|  | HV             | Subtransmission Cable      | Subtransmission UG up to 66kV (PILC)            | km      |         |         | 100.00% |               |                     | 3  |        |
|  | HV             | Subtransmission Cable      | Subtransmission UG 110kV+ (XLPE)                | km      |         |         |         |               | N/A                 |  |        |
|  | HV             | Subtransmission Cable      | Subtransmission UG 110kV+ (Oil pressurised)     | km      |         |         |         |               | N/A                 |  |        |
|  | HV             | Subtransmission Cable      | Subtransmission UG 110kV+ (Gas Pressurised)     | km      |         |         |         |               | N/A                 |  |        |
|  | HV             | Subtransmission Cable      | Subtransmission UG 110kV+ (PILC)                | km      |         |         |         |               | N/A                 |  |        |
|  | HV             | Subtransmission Cable      | Subtransmission submarine cable                 | km      |         |         |         |               | N/A                 |  |        |
|  | HV             | Zone substation Buildings  | Zone substations up to 66kV                     | No.     |         |         | 44.00%  | 56.00%        |                     | 4  |        |
|  | HV             | Zone substation Buildings  | Zone substations 110kV+                         | No.     |         |         |         |               | N/A                 |  |        |
|  | HV             | Zone substation switchgear | 22/33kV CB (Indoor)                             | No.     |         |         | 34.90%  | 65.10%        |                     | 4  |        |
|  | HV             | Zone substation switchgear | 22/33kV CB (Outdoor)                            | No.     |         |         | 58.00%  | 42.00%        |                     | 4  |        |
|  | HV             | Zone substation switchgear | 33kV Switch (Ground Mounted)                    | No.     |         |         |         |               | N/A                 |  |        |
|  | HV             | Zone substation switchgear | 33kV Switch (Pole Mounted)                      | No.     |         |         | 85.00%  | 15.00%        |                     | 4  |        |
|  | HV             | Zone substation switchgear | 33kV RMU  | No.     |         |         | 100.00% |               |                     | 4  |        |
|  | HV             | Zone substation switchgear | 50/66/110kV CB (Indoor)                         | No.     |         |         |         |               | N/A                 |  |        |
|  | HV             | Zone substation switchgear | 50/66/110kV CB (Outdoor)                        | No.     |         |         |         |               | N/A                 |  |        |
|  | HV             | Zone substation switchgear | 3.3/6.6/11/22kV CB (ground mounted)             | No.     |         |         | 72.00%  | 28.00%        |                     | 4  |        |
|  | HV             | Zone substation switchgear | 3.3/6.6/11/22kV CB (pole mounted)               | No.     |         |         | 31.00%  | 69.00%        |                     | 4  |        |



Company Name **Marlborough Lines Ltd**  
 AMP Planning Period **1 April 2015 – 31 March 2025**

**SCHEDULE 12a: REPORT ON ASSET CONDITION**

This schedule requires a breakdown of asset condition by asset class as at the start of the forecast year. The data accuracy assessment relates to the percentage values disclosed in the asset condition columns. Also required is a forecast of the percentage of units to be replaced in the next 5 years. All information should be consistent with the information provided in the AMP and the expenditure on assets forecast in Schedule 11a. All units relating to cable and line assets, that are expressed in km, refer to circuit lengths.

| sch ref |                | Asset condition at start of planning period (percentage of units by grade) |  |         |         |         |         |               |                     |  |       |
|---------|----------------|--|--|---------|---------|---------|---------|---------------|---------------------|--|-------|
| Voltage | Asset category | Asset class  | Units  | Grade 1 | Grade 2 | Grade 3 | Grade 4 | Grade unknown | Data accuracy (1-4) | % of asset forecast to be replaced in next 5 years |       |
| 45      | HV             | Zone Substation Transformer  | Zone Substation Transformers                                     | No.     |         |         | 87.00%  | 13.00%        |                     | 4  |       |
| 46      | HV             | Distribution Line  | Distribution OH Open Wire Conductor                              | km      | 0.90%   |         | 92.80%  | 6.30%         |                     | 3  | 9.00% |
| 47      | HV             | Distribution Line  | Distribution OH Aerial Cable Conductor                           | km      |         |         |         |               | N/A                 |  |       |
| 48      | HV             | Distribution Line  | SWER conductor   | km      |         | 2.80%   | 95.60%  | 1.60%         |                     | 3  |       |
| 49      | HV             | Distribution Cable   | Distribution UG XLPE or PVC                                      | km      |         |         | 86.00%  | 14.00%        |                     | 3  |       |
| 50      | HV             | Distribution Cable   | Distribution UG PILC   | km      |         |         | 100.00% |               |                     | 3  |       |
| 51      | HV             | Distribution Cable   | Distribution Submarine Cable                                     | km      |         |         |         |               | N/A                 |  |       |
| 52      | HV             | Distribution switchgear  | 3.3/6.6/11/22kV CB (pole mounted) - reclosers and sectionalisers | No.     |         |         | 58.00%  | 42.00%        |                     | 4  |       |
| 53      | HV             | Distribution switchgear  | 3.3/6.6/11/22kV CB (indoor)                                      | No.     |         |         | 88.00%  | 12.00%        |                     | 4  |       |
| 54      | HV             | Distribution switchgear  | 3.3/6.6/11/22kV Switches and fuses (pole mounted)                | No.     |         |         | 77.00%  | 23.00%        |                     | 3  |       |
| 55      | HV             | Distribution switchgear  | 3.3/6.6/11/22kV Switch (ground mounted) - except RMU             | No.     |         |         | 100.00% |               |                     | 4  |       |
| 56      | HV             | Distribution switchgear  | 3.3/6.6/11/22kV RMU  | No.     |         |         | 75.00%  | 25.00%        |                     | 4  |       |
| 57      | HV             | Distribution Transformer   | Pole Mounted Transformer   | No.     |         | 0.80%   | 92.60%  | 6.60%         |                     | 3  | 7.00% |
| 58      | HV             | Distribution Transformer   | Ground Mounted Transformer                                       | No.     |         |         | 91.00%  | 9.00%         |                     | 4  | 7.00% |
| 59      | HV             | Distribution Transformer   | Voltage regulators   | No.     |         |         | 93.00%  | 7.00%         |                     | 4  | 3.00% |
| 60      | HV             | Distribution Substations   | Ground Mounted Substation Housing                                | No.     |         |         |         |               | N/A                 |  |       |
| 61      | LV             | LV Line  | LV OH Conductor  | km      |         | 3.00%   | 96.00%  | 1.00%         |                     | 3  | 3.00% |
| 62      | LV             | LV Cable   | LV UG Cable  | km      |         |         | 89.00%  | 11.00%        |                     | 3  | -     |
| 63      | LV             | LV Streetlighting  | LV OH/UG Streetlight circuit                                     | km      |         |         | 84.00%  | 16.00%        |                     | 3  | -     |
| 64      | LV             | Connections  | OH/UG consumer service connections                               | No.     |         | 3.00%   | 93.20%  | 3.80%         |                     | 4  | 3.50% |
| 65      | All            | Protection   | Protection relays (electromechanical, solid state and numeric)   | No.     |         |         | 64.00%  | 36.00%        |                     | 4  | 4.00% |
| 66      | All            | SCADA and communications   | SCADA and communications equipment operating as a single system  | Lot     |         |         | 90.00%  | 10.00%        |                     | 3  |       |
| 67      | All            | Capacitor Banks  | Capacitors including controls                                    | No.     |         |         |         |               | N/A                 |  |       |
| 68      | All            | Load Control   | Centralised plant  | Lot     |         |         | 100.00% |               |                     | 4  |       |
| 69      | All            | Load Control   | Relays   | No.     |         |         |         |               | N/A                 |  |       |
| 70      | All            | Civils   | Cable Tunnels  | km      |         |         |         |               | N/A                 |  |       |

Company Name **Marlborough Lines Ltd**  
 AMP Planning Period **1 April 2015 – 31 March 2025**

**SCHEDULE 12b: REPORT ON FORECAST CAPACITY**

This schedule requires a breakdown of current and forecast capacity and utilisation for each zone substation and current distribution transformer capacity. The data provided should be consistent with the information provided in the AMP. Information provided in this table should relate to the operation of the network in its normal steady state configuration.

| sch ref | Existing Zone Substations                       | Current Peak Load (MVA) | Installed Firm Capacity (MVA) | Security of Supply Classification (type) | Transfer Capacity (MVA) | Utilisation of Installed Firm Capacity % | Installed Firm Capacity +5 years (MVA) | Utilisation of Installed Firm Capacity + 5yrs % | Installed Firm Capacity Constraint +5 years (cause) | Explanation   |  |
|---------|---|-------------------------|-------------------------------|--|-------------------------|--|--|---|---|---|--|
| 7       | <b>12b(i): System Growth - Zone Substations</b> |                         |                               |  |                         |  |  |   |   |   |  |
| 9       | Leefield  | 1.1                     | 5                             | n  | 1                       | 22%                                      | 5                                      | 25  | No constraint within +5 years                       |   |  |
| 10      | Linkwater                                       | 3.7                     | 5                             | n  | 1                       | 74%                                      | 5                                      | 74  | No constraint within +5 years                       |   |  |
| 11      | Havelock  | 4                       | 5                             | n-1                                      | 2                       | 80%                                      | 5                                      | 80  | No constraint within +5 years                       |   |  |
| 12      | Nelson St                                       | 14.7                    | 15                            | n-1                                      | 7.5                     | 98%                                      | 15                                     | 98  | No constraint within +5 years                       |   |  |
| 13      | Picton  | 6.7                     | 15                            | n-1                                      | 0                       | 45%                                      | 15                                     | 44  | No constraint within +5 years                       |   |  |
| 14      | Rai Valley                                      | 1.9                     | 3                             | n-1                                      | 1                       | 63%                                      | 4                                      | 64  | No constraint within +5 years                       |   |  |
| 15      | Redwoodtown                                     | 10.3                    | 15                            | n-1                                      | 7.5                     | 69%                                      | 15                                     | 69  | No constraint within +5 years                       |   |  |
| 16      | Renwick   | 9.5                     | 10                            | n-1                                      | 5                       | 95%                                      | 10                                     | 104   | Transformer   | Open point may need moving                          |  |
| 17      | Riverlands                                      | 9.6                     | 10                            | n-1                                      | 7.5                     | 96%                                      | 10                                     | 112   | Transformer   | Open point may need moving                          |  |
| 18      | Seddon  | 5.3                     | 10                            | n-1                                      | 1                       | 53%                                      | 10                                     | 72  | No constraint within +5 years                       |   |  |
| 19      | Spring Creek                                    | 4                       | 5                             | n-1                                      | 5                       | 80%                                      | 5                                      | 88  | No constraint within +5 years                       |   |  |
| 20      | Springlands                                     | 10.4                    | 15                            | n-1                                      | 10                      | 69%                                      | 15                                     | 69  | No constraint within +5 years                       |   |  |
| 21      | Ward  | 1.7                     | 2                             | n  | 1                       | 85%                                      | 2                                      | 95  | No constraint within +5 years                       | will need reviewing, Transformers are 56 years old. |  |
| 22      | Waters  | 6.8                     | 15                            | n-1                                      | 10                      | 45%                                      | 15                                     | 45  | No constraint within +5 years                       |   |  |
| 23      | Woodbourne                                      | 7.7                     | 10                            | n-1                                      | 5                       | 77%                                      | 10                                     | 84  | No constraint within +5 years                       |   |  |
| 24      | Cloudy bay                                      | 4.2                     | 15                            | n-1                                      | 5                       | 28%                                      | 15                                     | 33  | No constraint within +5 years                       | Some load to be moved from Riverlands               |  |
| 25      |   |                         |                               |  |                         | -  |  |   |   |   |  |
| 26      |   |                         |                               |  |                         | -  |  |   |   |   |  |
| 27      |   |                         |                               |  |                         | -  |  |   |   |   |  |
| 28      |   |                         |                               |  |                         | -  |  |   |   |   |  |

<sup>1</sup> Extend forecast capacity table as necessary to disclose all capacity by each zone substation

**12b(ii): Transformer Capacity**

|   | (MVA)      |
|---|------------|
| Distribution transformer capacity (EDB owned)     | 314        |
| Distribution transformer capacity (Non-EDB owned) | 18         |
| <b>Total distribution transformer capacity</b>    | <b>332</b> |
| <br>  |            |
| <b>Zone substation transformer capacity</b>       | <b>302</b> |

Company Name **Marlborough Lines Ltd**  
 AMP Planning Period **1 April 2015 – 31 March 2025**

**SCHEDULE 12C: REPORT ON FORECAST NETWORK DEMAND**

This schedule requires a forecast of new connections (by consumer type), peak demand and energy volumes for the disclosure year and a 5 year planning period. The forecasts should be consistent with the supporting information set out in the AMP as well as the assumptions used in developing the expenditure forecasts in Schedule 11a and Schedule 11b and the capacity and utilisation forecasts in Schedule 12b.

sch ref

| 7<br>8<br>9<br>10<br>11<br>12<br>13<br>14<br>15<br>16<br>17<br>18<br>19<br>20<br>21<br>22<br>23<br>24<br>25<br>26<br>27<br>28<br>29<br>30<br>31<br>32<br>33<br>34<br>35<br>36<br>37<br>38<br>39<br>40 |  | <b>12c(i): Consumer Connections</b>               |               | Number of connections                          |                   |                   |                   |                   |                   |
|---|--|---|---------------|--|-------------------|-------------------|-------------------|-------------------|-------------------|
|   |  | Number of ICPs connected in year by consumer type |               | Current Year CY<br>for year ended<br>31 Mar 15 | CY+1<br>31 Mar 16 | CY+2<br>31 Mar 17 | CY+3<br>31 Mar 18 | CY+4<br>31 Mar 19 | CY+5<br>31 Mar 20 |
| Consumer types defined by EDB*  |  |   |               |  |                   |                   |                   |                   |                   |
| Domestic  |  | 21,100  | 21,200        | 21,300   | 21,400            | 21,500            | 21,600            |                   |                   |
| Small Commercial  |  | 3,280   | 3,280         | 3,280  | 3,280             | 3,280             | 3,280             |                   |                   |
| Large Commercial/Industrial   |  | 116   | 116           | 117  | 117               | 118               | 119               |                   |                   |
| Irrigation  |  | 340   | 350           | 360  | 370               | 380               | 390               |                   |                   |
| <b>Connections total</b>  |  | <b>24,836</b>                                     | <b>24,946</b> | <b>25,057</b>                                  | <b>25,167</b>     | <b>25,278</b>     | <b>25,389</b>     |                   |                   |
| *Include additional rows if needed  |  |   |               |  |                   |                   |                   |                   |                   |
| <b>Distributed generation</b>   |  |   |               |  |                   |                   |                   |                   |                   |
| Number of connections   |  | 90  | 144           | 230  | 323               | 452               | 632               |                   |                   |
| Installed connection capacity of distributed generation (MVA)   |  | 1   | 1             | 1  | 2                 | 3                 | 4                 |                   |                   |
| <b>12c(ii) System Demand</b>  |  |   |               |  |                   |                   |                   |                   |                   |
| <b>Maximum coincident system demand (MW)</b>  |  |   |               |  |                   |                   |                   |                   |                   |
| GXP demand  |  | 71  | 71            | 71   | 71                | 71                | 71                |                   |                   |
| plus Distributed generation output at HV and above  |  | 2   | 2             | 2  | 2                 | 2                 | 2                 |                   |                   |
| <b>Maximum coincident system demand</b>   |  | <b>73</b>   | <b>73</b>     | <b>73</b>                                      | <b>73</b>         | <b>73</b>         | <b>73</b>         |                   |                   |
| less Net transfers to (from) other EDBs at HV and above   |  | -   | -             | -  | -                 | -                 | -                 |                   |                   |
| <b>Demand on system for supply to consumers' connection points</b>  |  | <b>73</b>   | <b>73</b>     | <b>73</b>                                      | <b>73</b>         | <b>73</b>         | <b>73</b>         |                   |                   |
| <b>Electricity volumes carried (GWh)</b>  |  |   |               |  |                   |                   |                   |                   |                   |
| Electricity supplied from GXPs  |  | 371   | 375           | 378  | 382               | 386               | 390               |                   |                   |
| less Electricity exports to GXPs  |  | -   | -             | -  | -                 | -                 | -                 |                   |                   |
| plus Electricity supplied from distributed generation   |  | 14  | 14            | 14   | 14                | 14                | 14                |                   |                   |
| less Net electricity supplied to (from) other EDBs  |  | -   | -             | -  | -                 | -                 | -                 |                   |                   |
| <b>Electricity entering system for supply to ICPs</b>   |  | <b>385</b>  | <b>389</b>    | <b>393</b>                                     | <b>396</b>        | <b>400</b>        | <b>404</b>        |                   |                   |
| less Total energy delivered to ICPs   |  | 360   | 364           | 367  | 371               | 374               | 378               |                   |                   |
| <b>Losses</b>   |  | <b>25</b>   | <b>25</b>     | <b>26</b>                                      | <b>26</b>         | <b>26</b>         | <b>26</b>         |                   |                   |
| <b>Load factor</b>  |  | <b>60%</b>  | <b>61%</b>    | <b>61%</b>                                     | <b>62%</b>        | <b>63%</b>        | <b>63%</b>        |                   |                   |
| <b>Loss ratio</b>   |  | <b>6.5%</b>                                       | <b>6.5%</b>   | <b>6.5%</b>                                    | <b>6.5%</b>       | <b>6.5%</b>       | <b>6.5%</b>       |                   |                   |

|                            |                              |
|----------------------------|------------------------------|
| Company Name               | Marlborough Lines Ltd        |
| AMP Planning Period        | 1 April 2015 – 31 March 2025 |
| Network / Sub-network Name |                              |

**SCHEDULE 12d: REPORT FORECAST INTERRUPTIONS AND DURATION**

This schedule requires a forecast of SAIFI and SAIDI for disclosure and a 5 year planning period. The forecasts should be consistent with the supporting information set out in the AMP as well as the assumed impact of planned and unplanned SAIFI and SAIDI on the expenditures forecast provided in Schedule 11a and Schedule 11b.

| sch ref | for year ended                                   | Current Year CY | CY+1      | CY+2      | CY+3      | CY+4      | CY+5      |
|---------|--|-----------------|-----------|-----------|-----------|-----------|-----------|
|         |  | 31 Mar 15       | 31 Mar 16 | 31 Mar 17 | 31 Mar 18 | 31 Mar 19 | 31 Mar 20 |
| 8       |  |                 |           |           |           |           |           |
| 9       |  |                 |           |           |           |           |           |
| 10      | <b>SAIDI</b>                                     |                 |           |           |           |           |           |
| 11      | Class B (planned interruptions on the network)   | 80.0            | 70.0      | 70.0      | 70.0      | 70.0      | 70.0      |
| 12      | Class C (unplanned interruptions on the network) | 115.0           | 115.0     | 105.0     | 100.0     | 95.0      | 90.0      |
| 13      | <b>SAIFI</b>                                     |                 |           |           |           |           |           |
| 14      | Class B (planned interruptions on the network)   | 0.40            | 0.40      | 0.40      | 0.40      | 0.40      | 0.40      |
| 15      | Class C (unplanned interruptions on the network) | 1.30            | 1.27      | 1.25      | 1.17      | 1.14      | 1.10      |

Company Name

Marlborough Lines Ltd

AMP Planning Period

1 April 2015 – 31 March 2025

Asset Management Standard Applied

PAS55/ISO55001

**SCHEDULE 13: REPORT ON ASSET MANAGEMENT MATURITY**

This schedule requires information on the EDB'S self-assessment of the maturity of its asset management practices .

| Question No. | Function                  | Question  | Score | Evidence—Summary   | User Guidance | Why  | Who   | Record/document Information   |
|--------------|---------------------------|---|-------|--|---------------|--|---|---|
| 3            | Asset management policy   | To what extent has an asset management policy been documented, authorised and communicated?   | 2     | MLL has published a concise Asset Management Policy within the 2013 AMP. The policy is communicated through the publicity of the AMP. The AMP as a whole has been authorised by top-tier management, in turn authorising the AM policy.  |               | Widely used AM practice standards require an organisation to document, authorise and communicate its asset management policy (eg, as required in PAS 55 para 4.2 i). A key pre-requisite of any robust policy is that the organisation's top management must be seen to endorse and fully support it. Also vital to the effective implementation of the policy, is to tell the appropriate people of its content and their obligations under it. Where an organisation outsources some of its asset-related activities, then these people and their organisations must equally be made aware of the policy's content. Also, there may be other stakeholders, such as regulatory authorities and shareholders who should be made aware of it. | Top management. The management team that has overall responsibility for asset management.   | The organisation's asset management policy, its organisational strategic plan, documents indicating how the asset management policy was based upon the needs of the organisation and evidence of communication.   |
| 10           | Asset management strategy | What has the organisation done to ensure that its asset management strategy is consistent with other appropriate organisational policies and strategies, and the needs of stakeholders? | 2     | The 2013 AMP includes an AM Strategy that describes how the AM Policy is to be implemented taking into consideration key stakeholder requirements. The AMP indicates alignment between the Vision, Mission, AM Policy and the AM Strategy. The AM strategy has been authorised by top level management.      |               | In setting an organisation's asset management strategy, it is important that it is consistent with any other policies and strategies that the organisation has and has taken into account the requirements of relevant stakeholders. This question examines to what extent the asset management strategy is consistent with other organisational policies and strategies (eg, as required by PAS 55 para 4.3.1 b) and has taken account of stakeholder requirements as required by PAS 55 para 4.3.1 c). Generally, this will take into account the same policies, strategies and stakeholder requirements as covered in drafting the asset management policy but at a greater level of detail.  | Top management. The organisation's strategic planning team. The management team that has overall responsibility for asset management.   | The organisation's asset management strategy document and other related organisational policies and strategies. Other than the organisation's strategic plan, these could include those relating to health and safety, environmental, etc. Results of stakeholder consultation. |
| 11           | Asset management strategy | In what way does the organisation's asset management strategy take account of the lifecycle of the assets, asset types and asset systems over which the organisation has stewardship?   | 2     | The AMP sets out the key asset lifecycle phases of distribution assets, with particular attention given to those classes that are potentially declining condition as they approach predicted end-of-life. Key asset management activities include rigorous inspection and maintenance schedules.             |               | Good asset stewardship is the hallmark of an organisation compliant with widely used AM standards. A key component of this is the need to take account of the lifecycle of the assets, asset types and asset systems. (For example, this requirement is recognised in 4.3.1 d) of PAS 55). This question explores what an organisation has done to take lifecycle into account in its asset management strategy.   | Top management. People in the organisation with expert knowledge of the assets, asset types, asset systems and their associated life-cycles. The management team that has overall responsibility for asset management. Those responsible for developing and adopting methods and processes used in asset management | The organisation's documented asset management strategy and supporting working documents.   |
| 26           | Asset management plan(s)  | How does the organisation establish and document its asset management plan(s) across the life cycle activities of its assets and asset systems?   | 2     | The AMP includes significant content on the sourcing, installation and operation of major distribution asset classes through to end-of-life. The AMP includes a description of the testing and inspection regimes for key asset classes such as zone substations, distribution substations and oil switches. |               | The asset management strategy need to be translated into practical plan(s) so that all parties know how the objectives will be achieved. The development of plan(s) will need to identify the specific tasks and activities required to optimize costs, risks and performance of the assets and/or asset system(s), when they are to be carried out and the resources required.  | The management team with overall responsibility for the asset management system. Operations, maintenance and engineering managers.  | The organisation's asset management plan(s).  |

Company Name

Marlborough Lines Ltd

AMP Planning Period

1 April 2015 – 31 March 2025

Asset Management Standard Applied

PASS5/ISO55001

**SCHEDULE 13: REPORT ON ASSET MANAGEMENT MATURITY (cont)**

| Question No. | Function                  | Question  | Maturity Level 0  | Maturity Level 1   | Maturity Level 2  | Maturity Level 3   | Maturity Level 4  |
|--------------|---------------------------|---|---|--|---|--|---|
| 3            | Asset management policy   | To what extent has an asset management policy been documented, authorised and communicated?   | The organisation does not have a documented asset management policy.  | The organisation has an asset management policy, but it has not been authorised by top management, or it is not influencing the management of the assets.  | The organisation has an asset management policy, which has been authorised by top management, but it has had limited circulation. It may be in use to influence development of strategy and planning but its effect is limited.   | The asset management policy is authorised by top management, is widely and effectively communicated to all relevant employees and stakeholders, and used to make these persons aware of their asset related obligations.   | The organisation's process(es) surpass the standard required to comply with requirements set out in a recognised standard.<br><br>The assessor is advised to note in the Evidence section why this is the case and the evidence seen. |
| 10           | Asset management strategy | What has the organisation done to ensure that its asset management strategy is consistent with other appropriate organisational policies and strategies, and the needs of stakeholders? | The organisation has not considered the need to ensure that its asset management strategy is appropriately aligned with the organisation's other organisational policies and strategies or with stakeholder requirements.<br><br>OR<br>The organisation does not have an asset management strategy. | The need to align the asset management strategy with other organisational policies and strategies as well as stakeholder requirements is understood and work has started to identify the linkages or to incorporate them in the drafting of asset management strategy.                             | Some of the linkages between the long-term asset management strategy and other organisational policies, strategies and stakeholder requirements are defined but the work is fairly well advanced but still incomplete.            | All linkages are in place and evidence is available to demonstrate that, where appropriate, the organisation's asset management strategy is consistent with its other organisational policies and strategies. The organisation has also identified and considered the requirements of relevant stakeholders. | The organisation's process(es) surpass the standard required to comply with requirements set out in a recognised standard.<br><br>The assessor is advised to note in the Evidence section why this is the case and the evidence seen. |
| 11           | Asset management strategy | In what way does the organisation's asset management strategy take account of the lifecycle of the assets, asset types and asset systems over which the organisation has stewardship?   | The organisation has not considered the need to ensure that its asset management strategy is produced with due regard to the lifecycle of the assets, asset types or asset systems that it manages.<br><br>OR<br>The organisation does not have an asset management strategy.                       | The need is understood, and the organisation is drafting its asset management strategy to address the lifecycle of its assets, asset types and asset systems.  | The long-term asset management strategy takes account of the lifecycle of some, but not all, of its assets, asset types and asset systems.  | The asset management strategy takes account of the lifecycle of all of its assets, asset types and asset systems.  | The organisation's process(es) surpass the standard required to comply with requirements set out in a recognised standard.<br><br>The assessor is advised to note in the Evidence section why this is the case and the evidence seen. |
| 26           | Asset management plan(s)  | How does the organisation establish and document its asset management plan(s) across the life cycle activities of its assets and asset systems?   | The organisation does not have an identifiable asset management plan(s) covering asset systems and critical assets.   | The organisation has asset management plan(s) but they are not aligned with the asset management strategy and objectives and do not take into consideration the full asset life cycle (including asset creation, acquisition, enhancement, utilisation, maintenance decommissioning and disposal). | The organisation is in the process of putting in place comprehensive, documented asset management plan(s) that cover all life cycle activities, clearly aligned to asset management objectives and the asset management strategy. | Asset management plan(s) are established, documented, implemented and maintained for asset systems and critical assets to achieve the asset management strategy and asset management objectives across all life cycle phases.  | The organisation's process(es) surpass the standard required to comply with requirements set out in a recognised standard.<br><br>The assessor is advised to note in the Evidence section why this is the case and the evidence seen. |

Company Name

Marlborough Lines Ltd

AMP Planning Period

1 April 2015 – 31 March 2025

Asset Management Standard Applied

PAS55/ISO55001

**SCHEDULE 13: REPORT ON ASSET MANAGEMENT MATURITY (cont)**

| Question No. | Function                 | Question   | Score | Evidence—Summary   | User Guidance | Why  | Who   | Record/document Information   |
|--------------|--------------------------|--|-------|--|---------------|--|---|---|
| 27           | Asset management plan(s) | How has the organisation communicated its plan(s) to all relevant parties to a level of detail appropriate to the receiver's role in their delivery?   | 3     | The AMP is publicly available on the MLL website, is sent to the regulator annually, and is submitted to the BoD for authorisation. Key staff are aware of the contents of the AMP. Key documents referred to within the AMP such as Network Design and Construction Standards and Emergency Procedure Plans   |               | Plans will be ineffective unless they are communicated to all those, including contracted suppliers and those who undertake enabling function(s). The plan(s) need to be communicated in a way that is relevant to those who need to use them.   | The management team with overall responsibility for the asset management system. Delivery functions and suppliers.  | Distribution lists for plan(s). Documents derived from plan(s) which detail the receivers role in plan delivery. Evidence of communication.   |
| 29           | Asset management plan(s) | How are designated responsibilities for delivery of asset plan actions documented?   | 3     | The AMP clearly defines the functions of all executive level staff. The long-term asset management responsibilities of the Engineering Manager and the short-term responsibilities of the Operations Manager are clearly distinguished between. MLL's ISO system has defines the responsibilities of each individual job description, including staff roles involved   |               | The implementation of asset management plan(s) relies on (1) actions being clearly identified, (2) an owner allocated and (3) that owner having sufficient delegated responsibility and authority to carry out the work required. It also requires alignment of actions across the organisation. This question explores how well the plan(s) set out responsibility for delivery of asset plan actions.  | The management team with overall responsibility for the asset management system. Operations, maintenance and engineering managers. If appropriate, the performance management team.   | The organisation's asset management plan(s). Documentation defining roles and responsibilities of individuals and organisational departments. |
| 31           | Asset management plan(s) | What has the organisation done to ensure that appropriate arrangements are made available for the efficient and cost effective implementation of the plan(s)?<br><br>(Note this is about resources and enabling support) | 3     | The continuance of strong cash flows from operation has resulted in sufficient resources for the company to adequately perform its asset management practices. Significant OpEx and CapEx tasks are prioritised during the formation of annual budgets. Relatively constant asset management works have resulted in a resource base that is readily available. Comprehensive Design and Construction Standards   |               | It is essential that the plan(s) are realistic and can be implemented, which requires appropriate resources to be available and enabling mechanisms in place. This question explores how well this is achieved. The plan(s) not only need to consider the resources directly required and timescales, but also the enabling activities, including for example, training requirements, supply chain capability and procurement timescales.  | The management team with overall responsibility for the asset management system. Operations, maintenance and engineering managers. If appropriate, the performance management team. If appropriate, the performance management team. Where appropriate the procurement team and service providers working on the organisation's asset-related activities. | The organisation's asset management plan(s). Documented processes and procedures for the delivery of the asset management plan.               |
| 33           | Contingency planning     | What plan(s) and procedure(s) does the organisation have for identifying and responding to incidents and emergency situations and ensuring continuity of critical asset management activities?                           | 3     | The AMP includes a high level risk register that identifies most electrical, environmental, business and regulatory risks that MLL is exposed to, as well as highlighting high-impact low-probability risks. The 'Emergency Preparedness Plan' and 'Management of Planned and Unplanned Outages' internal publications act as an in-depth procedure for risk response and risk management following an event with significant detrimental impact to the network. |               | Widely used AM practice standards require that an organisation has plan(s) to identify and respond to emergency situations. Emergency plan(s) should outline the actions to be taken to respond to specified emergency situations and ensure continuity of critical asset management activities including the communication to, and involvement of, external agencies. This question assesses if, and how well, these plan(s) triggered, implemented and resolved in the event of an incident. The plan(s) should be appropriate to the level of risk as determined by the organisation's risk assessment methodology. It is also a requirement that relevant personnel are competent and trained. | The manager with responsibility for developing emergency plan(s). The organisation's risk assessment team. People with designated duties within the plan(s) and procedure(s) for dealing with incidents and emergency situations.   | The organisation's plan(s) and procedure(s) for dealing with emergencies. The organisation's risk assessments and risk registers.             |

Company Name

Marlborough Lines Ltd

AMP Planning Period

1 April 2015 – 31 March 2025

Asset Management Standard Applied

PASS5/ISO55001

**SCHEDULE 13: REPORT ON ASSET MANAGEMENT MATURITY (cont)**

| Question No. | Function                 | Question   | Maturity Level 0  | Maturity Level 1   | Maturity Level 2  | Maturity Level 3   | Maturity Level 4  |
|--------------|--------------------------|--|---|--|---|--|---|
| 27           | Asset management plan(s) | How has the organisation communicated its plan(s) to all relevant parties to a level of detail appropriate to the receiver's role in their delivery?   | The organisation does not have plan(s) or their distribution is limited to the authors.   | The plan(s) are communicated to some of those responsible for delivery of the plan(s).<br>OR<br>Communicated to those responsible for delivery is either irregular or ad-hoc.  | The plan(s) are communicated to most of those responsible for delivery but there are weaknesses in identifying relevant parties resulting in incomplete or inappropriate communication. The organisation recognises improvement is needed as is working towards resolution. | The plan(s) are communicated to all relevant employees, stakeholders and contracted service providers to a level of detail appropriate to their participation or business interests in the delivery of the plan(s) and there is confirmation that they are being used effectively.   | The organisation's process(es) surpass the standard required to comply with requirements set out in a recognised standard.<br><br>The assessor is advised to note in the Evidence section why this is the case and the evidence seen. |
| 29           | Asset management plan(s) | How are designated responsibilities for delivery of asset plan actions documented?   | The organisation has not documented responsibilities for delivery of asset plan actions.  | Asset management plan(s) inconsistently document responsibilities for delivery of plan actions and activities and/or responsibilities and authorities for implementation inadequate and/or delegation level inadequate to ensure effective delivery and/or contain misalignments with organisational accountability. | Asset management plan(s) consistently document responsibilities for the delivery of actions but responsibility/authority levels are inappropriate/ inadequate, and/or there are misalignments within the organisation.  | Asset management plan(s) consistently document responsibilities for the delivery actions and there is adequate detail to enable delivery of actions. Designated responsibility and authority for achievement of asset plan actions is appropriate.   | The organisation's process(es) surpass the standard required to comply with requirements set out in a recognised standard.<br><br>The assessor is advised to note in the Evidence section why this is the case and the evidence seen. |
| 31           | Asset management plan(s) | What has the organisation done to ensure that appropriate arrangements are made available for the efficient and cost effective implementation of the plan(s)?<br><br>(Note this is about resources and enabling support) | The organisation has not considered the arrangements needed for the effective implementation of plan(s).  | The organisation recognises the need to ensure appropriate arrangements are in place for implementation of asset management plan(s) and is in the process of determining an appropriate approach for achieving this.   | The organisation has arrangements in place for the implementation of asset management plan(s) but the arrangements are not yet adequately efficient and/or effective. The organisation is working to resolve existing weaknesses.   | The organisation's arrangements fully cover all the requirements for the efficient and cost effective implementation of asset management plan(s) and realistically address the resources and timescales required, and any changes needed to functional policies, standards, processes and the asset management information system. | The organisation's process(es) surpass the standard required to comply with requirements set out in a recognised standard.<br><br>The assessor is advised to note in the Evidence section why this is the case and the evidence seen. |
| 33           | Contingency planning     | What plan(s) and procedure(s) does the organisation have for identifying and responding to incidents and emergency situations and ensuring continuity of critical asset management activities?                           | The organisation has not considered the need to establish plan(s) and procedure(s) to identify and respond to incidents and emergency situations. | The organisation has some ad-hoc arrangements to deal with incidents and emergency situations, but these have been developed on a reactive basis in response to specific events that have occurred in the past.  | Most credible incidents and emergency situations are identified. Either appropriate plan(s) and procedure(s) are incomplete for critical activities or they are inadequate. Training/ external alignment may be incomplete.   | Appropriate emergency plan(s) and procedure(s) are in place to respond to credible incidents and manage continuity of critical asset management activities consistent with policies and asset management objectives. Training and external agency alignment is in place.   | The organisation's process(es) surpass the standard required to comply with requirements set out in a recognised standard.<br><br>The assessor is advised to note in the Evidence section why this is the case and the evidence seen. |



Company Name

Marlborough Lines Ltd

AMP Planning Period

1 April 2015 – 31 March 2025

Asset Management Standard Applied

PAS55/ISO55001

**SCHEDULE 13: REPORT ON ASSET MANAGEMENT MATURITY (cont)**

| Question No. | Function                                   | Question  | Score | Evidence—Summary   | User Guidance | Why  | Who  | Record/document Information  |
|--------------|--|---|-------|--|---------------|--|--|--|
| 37           | Structure, authority and responsibilities  | What has the organisation done to appoint member(s) of its management team to be responsible for ensuring that the organisation's assets deliver the requirements of the asset management strategy, objectives and plan(s)?                                   | 3     | Marlborough Lines management staff who are responsible for planning, operations and works delivery report directly to the Managing Director. Management personnel who ensure asset management practices are carried out have been appointed based on their experience and industry qualifications.                             |               | In order to ensure that the organisation's assets and asset systems deliver the requirements of the asset management policy, strategy and objectives responsibilities need to be allocated to appropriate people who have the necessary authority to fulfil their responsibilities. (This question, relates to the organisation's assets eg, para b), s 4.4.1 of PAS 55, making it therefore distinct from the requirement contained in para a), s 4.4.1 of PAS 55).   | Top management. People with management responsibility for the delivery of asset management policy, strategy, objectives and plan(s). People working on asset-related activities.   | Evidence that managers with responsibility for the delivery of asset management policy, strategy, objectives and plan(s) have been appointed and have assumed their responsibilities. Evidence may include the organisation's documents relating to its asset management system, organisational charts, job descriptions of post-holders, annual targets/objectives and personal development plan(s) of post-holders as appropriate. |
| 40           | Structure, authority and responsibilities  | What evidence can the organisation's top management provide to demonstrate that sufficient resources are available for asset management?  | 2     | Sufficient levels of planning staff are employed to meet demand. Principal contractors ensure staffing levels are adequate to meet annual AM requirements and can vary external work if required. Funding constraints for the performance of AM tasks are minimal.   |               | Optimal asset management requires top management to ensure sufficient resources are available. In this context the term 'resources' includes manpower, materials, funding and service provider support.  | Top management. The management team that has overall responsibility for asset management. Risk management team. The organisation's managers involved in day-to-day supervision of asset-related activities, such as frontline managers, engineers, foremen and chargehands as appropriate.   | Evidence demonstrating that asset management plan(s) and/or the process(es) for asset management plan implementation consider the provision of adequate resources in both the short and long term. Resources include funding, materials, equipment, services provided by third parties and personnel (internal and service providers) with appropriate skills competencies and knowledge.  |
| 42           | Structure, authority and responsibilities  | To what degree does the organisation's top management communicate the importance of meeting its asset management requirements?  | 2     | The importance of meeting performance targets is communicated through the publication of the MLL Annual report and AMP, both of which declare AM goals, AM expenditure, and annual performance against those   |               | Widely used AM practice standards require an organisation to communicate the importance of meeting its asset management requirements such that personnel fully understand, take ownership of, and are fully engaged in the delivery of the asset management requirements (eg, PAS 55 s 4.4.1 g).   | Top management. The management team that has overall responsibility for asset management. People involved in the delivery of the asset management requirements.  | Evidence of such activities as road shows, written bulletins, workshops, team talks and management walk-about would assist an organisation to demonstrate it is meeting this requirement of PAS 55.  |
| 45           | Outsourcing of asset management activities | Where the organisation has outsourced some of its asset management activities, how has it ensured that appropriate controls are in place to ensure the compliant delivery of its organisational strategic plan, and its asset management policy and strategy? | 3     | The circulation of Network Design & Construction Standards and associated drawings specify minimum standards for all works. All contractors who perform work on the network guarantee performance against these standards. Upon completion of line work, as-built drawings are scrutinized for adherence to issued work packs. |               | Where an organisation chooses to outsource some of its asset management activities, the organisation must ensure that these outsourced process(es) are under appropriate control to ensure that all the requirements of widely used AM standards (eg, PAS 55) are in place, and the asset management policy, strategy objectives and plan(s) are delivered. This includes ensuring capabilities and resources across a time span aligned to life cycle management. The organisation must put arrangements in place to control the outsourced activities, whether it be to external providers or to other in-house departments. This question explores what the organisation does in this regard. | Top management. The management team that has overall responsibility for asset management. The manager(s) responsible for the monitoring and management of the outsourced activities. People involved with the procurement of outsourced activities. The people within the organisations that are performing the outsourced activities. The people impacted by the outsourced activity. | The organisation's arrangements that detail the compliance required of the outsourced activities. For example, this this could form part of a contract or service level agreement between the organisation and the suppliers of its outsourced activities. Evidence that the organisation has demonstrated to itself that it has assurance of compliance of outsourced activities.   |

Company Name

Marlborough Lines Ltd

AMP Planning Period

1 April 2015 – 31 March 2025

Asset Management Standard Applied

PASS5/ISO55001

**SCHEDULE 13: REPORT ON ASSET MANAGEMENT MATURITY (cont)**

| Question No. | Function                                   | Question  | Maturity Level 0  | Maturity Level 1   | Maturity Level 2   | Maturity Level 3   | Maturity Level 4  |
|--------------|--|---|---|--|--|--|---|
| 37           | Structure, authority and responsibilities  | What has the organisation done to appoint member(s) of its management team to be responsible for ensuring that the organisation's assets deliver the requirements of the asset management strategy, objectives and plan(s)?                                   | Top management has not considered the need to appoint a person or persons to ensure that the organisation's assets deliver the requirements of the asset management strategy, objectives and plan(s). | Top management understands the need to appoint a person or persons to ensure that the organisation's assets deliver the requirements of the asset management strategy, objectives and plan(s).                           | Top management has appointed an appropriate people to ensure the assets deliver the requirements of the asset management strategy, objectives and plan(s) but their areas of responsibility are not fully defined and/or they have insufficient delegated authority to fully execute their responsibilities. | The appointed person or persons have full responsibility for ensuring that the organisation's assets deliver the requirements of the asset management strategy, objectives and plan(s). They have been given the necessary authority to achieve this.                            | The organisation's process(es) surpass the standard required to comply with requirements set out in a recognised standard.<br><br>The assessor is advised to note in the Evidence section why this is the case and the evidence seen. |
| 40           | Structure, authority and responsibilities  | What evidence can the organisation's top management provide to demonstrate that sufficient resources are available for asset management?  | The organisation's top management has not considered the resources required to deliver asset management.  | The organisations top management understands the need for sufficient resources but there are no effective mechanisms in place to ensure this the case.   | A process exists for determining what resources are required for its asset management activities and in most cases these are available but in some instances resources remain insufficient.  | An effective process exists for determining the resources needed for asset management and sufficient resources are available. It can be demonstrated that resources are matched to asset management requirements.  | The organisation's process(es) surpass the standard required to comply with requirements set out in a recognised standard.<br><br>The assessor is advised to note in the Evidence section why this is the case and the evidence seen. |
| 42           | Structure, authority and responsibilities  | To what degree does the organisation's top management communicate the importance of meeting its asset management requirements?  | The organisation's top management has not considered the need to communicate the importance of meeting asset management requirements.   | The organisations top management understands the need to communicate the importance of meeting its asset management requirements but does not do so.   | Top management communicates the importance of meeting its asset management requirements but only to parts of the organisation.   | Top management communicates the importance of meeting its asset management requirements to all relevant parts of the organisation.   | The organisation's process(es) surpass the standard required to comply with requirements set out in a recognised standard.<br><br>The assessor is advised to note in the Evidence section why this is the case and the evidence seen. |
| 45           | Outsourcing of asset management activities | Where the organisation has outsourced some of its asset management activities, how has it ensured that appropriate controls are in place to ensure the compliant delivery of its organisational strategic plan, and its asset management policy and strategy? | The organisation has not considered the need to put controls in place.  | The organisation controls its outsourced activities on an ad-hoc basis, with little regard for ensuring for the compliant delivery of the organisational strategic plan and/or its asset management policy and strategy. | Controls systematically considered but currently only provide for the compliant delivery of some, but not all, aspects of the organisational strategic plan and/or its asset management policy and strategy. Gaps exist.   | Evidence exists to demonstrate that outsourced activities are appropriately controlled to provide for the compliant delivery of the organisational strategic plan, asset management policy and strategy, and that these controls are integrated into the asset management system | The organisation's process(es) surpass the standard required to comply with requirements set out in a recognised standard.<br><br>The assessor is advised to note in the Evidence section why this is the case and the evidence seen. |

Company Name

Marlborough Lines Ltd

AMP Planning Period

1 April 2015 – 31 March 2025

Asset Management Standard Applied

PAS55/ISO55001

**SCHEDULE 13: REPORT ON ASSET MANAGEMENT MATURITY (cont)**

| Question No. | Function                           | Question  | Score | Evidence—Summary  | User Guidance | Why  | Who  | Record/document Information  |
|--------------|------------------------------------|---|-------|---|---------------|--|--|--|
| 48           | Training, awareness and competence | How does the organisation develop plan(s) for the human resources required to undertake asset management activities - including the development and delivery of asset management strategy, process(es), objectives and plan(s)? | 2     | MLL Network and Contracting maintain competency registers to ensure all staff have suitable skills required for AM performance and continue with professional development. Job descriptions declare required competencies in order to suitably perform each role. Regular recruitment of trainees/graduates in contracting and management roles ensures staffing levels are maintained. MLL provides training for both contracting and management staff in return for agreed service contracts. |               | There is a need for an organisation to demonstrate that it has considered what resources are required to develop and implement its asset management system. There is also a need for the organisation to demonstrate that it has assessed what development plan(s) are required to provide its human resources with the skills and competencies to develop and implement its asset management systems. The timescales over which the plan(s) are relevant should be commensurate with the planning horizons within the asset management strategy considers e.g. if the asset management strategy considers 5, 10 and 15 year time scales then the human resources development plan(s) should align with these. Resources include both 'in house' and external resources who undertake asset management activities. | Senior management responsible for agreement of plan(s). Managers responsible for developing asset management strategy and plan(s). Managers with responsibility for development and recruitment of staff (including HR functions). Staff responsible for training. Procurement officers. Contracted service providers. | Evidence of analysis of future work load plan(s) in terms of human resources. Document(s) containing analysis of the organisation's own direct resources and contractors resource capability over suitable timescales. Evidence, such as minutes of meetings, that suitable management forums are monitoring human resource development plan(s). Training plan(s), personal development plan(s), contract and service level agreements.  |
| 49           | Training, awareness and competence | How does the organisation identify competency requirements and then plan, provide and record the training necessary to achieve the competencies?  | 3     | Competency requirements are maintained through the ISO9001 system. This highlights competency requirements for each position, regular training requirements, levels of staff competency, and required refresher training dates. All AM staff are trained to generally accepted New Zealand Standards.   |               | Widely used AM standards require that organisations to undertake a systematic identification of the asset management awareness and competencies required at each level and function within the organisation. Once identified the training required to provide the necessary competencies should be planned for delivery in a timely and systematic way. Any training provided must be recorded and maintained in a suitable format. Where an organisation has contracted service providers in place then it should have a means to demonstrate that this requirement is being met for their employees. (eg, PAS 55 refers to frameworks suitable for identifying competency requirements).   | Senior management responsible for agreement of plan(s). Managers responsible for developing asset management strategy and plan(s). Managers with responsibility for development and recruitment of staff (including HR functions). Staff responsible for training. Procurement officers. Contracted service providers. | Evidence of an established and applied competency requirements assessment process and plan(s) in place to deliver the required training. Evidence that the training programme is part of a wider, co-ordinated asset management activities training and competency programme. Evidence that training activities are recorded and that records are readily available (for both direct and contracted service provider staff) e.g. via organisation wide information system or local records database. |

|    |                                    |   |   |   |  |  |  |  |
|----|------------------------------------|---|---|---|--|--|--|--|
| 50 | Training, awareness and competence | How does the organization ensure that persons under its direct control undertaking asset management related activities have an appropriate level of competence in terms of education, training or experience? | 3 | Competency requirements are maintained through the ISO9001 system. This highlights competency requirements for each position, regular training requirements, levels of staff competency, and required refresher training dates. All AM staff are trained to generally accepted New Zealand Standards. |  | A critical success factor for the effective development and implementation of an asset management system is the competence of persons undertaking these activities. organisations should have effective means in place for ensuring the competence of employees to carry out their designated asset management function(s). Where an organisation has contracted service providers undertaking elements of its asset management system then the organisation shall assure itself that the outsourced service provider also has suitable arrangements in place to manage the competencies of its employees. The organisation should ensure that the individual and corporate competencies it requires are in place and actively monitor, develop and maintain an appropriate balance of these competencies. | Managers, supervisors, persons responsible for developing training programmes. Staff responsible for procurement and service agreements. HR staff and those responsible for recruitment. | Evidence of a competency assessment framework that aligns with established frameworks such as the asset management Competencies Requirements Framework (Version 2.0); National Occupational Standards for Management and Leadership; UK Standard for Professional Engineering Competence, Engineering Council, 2005. |
|----|------------------------------------|---|---|---|--|--|--|--|

Company Name

Marlborough Lines Ltd

AMP Planning Period

1 April 2015 – 31 March 2025

Asset Management Standard Applied

PASS5/ISO55001

**SCHEDULE 13: REPORT ON ASSET MANAGEMENT MATURITY (cont)**

| Question No. | Function                           | Question  | Maturity Level 0  | Maturity Level 1  | Maturity Level 2   | Maturity Level 3  | Maturity Level 4  |
|--------------|------------------------------------|---|---|---|--|---|---|
| 48           | Training, awareness and competence | How does the organisation develop plan(s) for the human resources required to undertake asset management activities - including the development and delivery of asset management strategy, process(es), objectives and plan(s)? | The organisation has not recognised the need for assessing human resources requirements to develop and implement its asset management system. | The organisation has recognised the need to assess its human resources requirements and to develop a plan(s). There is limited recognition of the need to align these with the development and implementation of its asset management system. | The organisation has developed a strategic approach to aligning competencies and human resources to the asset management system including the asset management plan but the work is incomplete or has not been consistently implemented. | The organisation can demonstrate that plan(s) are in place and effective in matching competencies and capabilities to the asset management system including the plan for both internal and contracted activities. Plans are reviewed integral to asset management system process(es). | The organisation's process(es) surpass the standard required to comply with requirements set out in a recognised standard.<br><br>The assessor is advised to note in the Evidence section why this is the case and the evidence seen. |
| 49           | Training, awareness and competence | How does the organisation identify competency requirements and then plan, provide and record the training necessary to achieve the competencies?  | The organisation does not have any means in place to identify competency requirements.  | The organisation has recognised the need to identify competency requirements and then plan, provide and record the training necessary to achieve the competencies.  | The organisation is the process of identifying competency requirements aligned to the asset management plan(s) and then plan, provide and record appropriate training. It is incomplete or inconsistently applied.                       | Competency requirements are in place and aligned with asset management plan(s). Plans are in place and effective in providing the training necessary to achieve the competencies. A structured means of recording the competencies achieved is in place.                              | The organisation's process(es) surpass the standard required to comply with requirements set out in a recognised standard.<br><br>The assessor is advised to note in the Evidence section why this is the case and the evidence seen. |

|    |                                    |   |   |  |   |   |   |
|----|------------------------------------|---|---|--|---|---|---|
| 50 | Training, awareness and competence | How does the organization ensure that persons under its direct control undertaking asset management related activities have an appropriate level of competence in terms of education, training or experience? | The organization has not recognised the need to assess the competence of person(s) undertaking asset management related activities. | Competency of staff undertaking asset management related activities is not managed or assessed in a structured way, other than formal requirements for legal compliance and safety management. | The organization is in the process of putting in place a means for assessing the competence of person(s) involved in asset management activities including contractors. There are gaps and inconsistencies. | Competency requirements are identified and assessed for all persons carrying out asset management related activities - internal and contracted. Requirements are reviewed and staff reassessed at appropriate intervals aligned to asset management requirements. | The organisation's process(es) surpass the standard required to comply with requirements set out in a recognised standard.<br><br>The assessor is advised to note in the Evidence section why this is the case and the evidence seen. |
|----|------------------------------------|---|---|--|---|---|---|

Company Name

Marlborough Lines Ltd

AMP Planning Period

1 April 2015 – 31 March 2025

Asset Management Standard Applied

PAS55/ISO55001

**SCHEDULE 13: REPORT ON ASSET MANAGEMENT MATURITY (cont)**

| Question No. | Function                                      | Question   | Score | Evidence—Summary   | User Guidance | Why   | Who  | Record/document Information  |
|--------------|---|--|-------|--|---------------|---|--|--|
| 53           | Communication, participation and consultation | How does the organisation ensure that pertinent asset management information is effectively communicated to and from employees and other stakeholders, including contracted service providers? | 3     | The issue and acknowledged receipt of the Network Design & Construction Standards ensure asset management information is suitably communicated to AM staff and external contractors. Regular planned meetings between the asset management, contracting and operations staff are held to plan and review annual AM activities. |               | Widely used AM practice standards require that pertinent asset management information is effectively communicated to and from employees and other stakeholders including contracted service providers. Pertinent information refers to information required in order to effectively and efficiently comply with and deliver asset management strategy, plan(s) and objectives. This will include for example the communication of the asset management policy, asset performance information, and planning information as appropriate to contractors.   | Top management and senior management representative(s), employee's representative(s), employee's trade union representative(s); contracted service provider management and employee representative(s); representative(s) from the organisation's Health, Safety and Environmental team. Key stakeholder representative(s). | Asset management policy statement prominently displayed on notice boards, intranet and internet; use of organisation's website for displaying asset performance data; evidence of formal briefings to employees, stakeholders and contracted service providers; evidence of inclusion of asset management issues in team meetings and contracted service provider contract meetings; newsletters, etc. |
| 59           | Asset Management System documentation         | What documentation has the organisation established to describe the main elements of its asset management system and interactions between them?  | 3     | The MLL AMP provides descriptions of major elements within the MLL AM fsystem. The ISO9001 system provides an overall process map of how these systems inter-relate with one another.  |               | Widely used AM practice standards require an organisation maintain up to date documentation that ensures that its asset management systems (ie, the systems the organisation has in place to meet the standards) can be understood, communicated and operated. (eg, s 4.5 of PAS 55 requires the maintenance of up to date documentation of the asset management system requirements specified throughout s 4 of PAS 55).   | The management team that has overall responsibility for asset management. Managers engaged in asset management activities.   | The documented information describing the main elements of the asset management system (process(es) and their interaction.   |
| 62           | Information management                        | What has the organisation done to determine what its asset management information system(s) should contain in order to support its asset management system?                                    | 3     | The recent implementation of EAM asset management software has called for a thorough review of asset management information requirements. This has been performed through regular planning meetings, consultation with AM software development companies, and cleansing of data stored in legacy systems.                      |               | Effective asset management requires appropriate information to be available. Widely used AM standards therefore require the organisation to identify the asset management information it requires in order to support its asset management system. Some of the information required may be held by suppliers.<br><br>The maintenance and development of asset management information systems is a poorly understood specialist activity that is akin to IT management but different from IT management. This group of questions provides some indications as to whether the capability is available and applied. Note: To be effective, an asset information management system requires the mobilisation of technology, people and process(es) that create, secure, make available and destroy the information required to support the asset management system. | The organisation's strategic planning team. The management team that has overall responsibility for asset management. Information management team. Operations, maintenance and engineering managers  | Details of the process the organisation has employed to determine what its asset information system should contain in order to support its asset management system. Evidence that this has been effectively implemented.   |

|    |                        |  |   |  |  |  |  |   |
|----|------------------------|--|---|--|--|--|--|---|
| 63 | Information management | How does the organisation maintain its asset management information system(s) and ensure that the data held within it (them) is of the requisite quality and accuracy and is consistent? | 3 | MLL employ a number of staff whose key responsibility is to manage the collection and processing of asset management data. Asset inspections are performed regularly based on asset class, location and condition. IT systems are in place for the automated population of databases |  | <p>The response to the questions is progressive. A higher scale cannot be awarded without achieving the requirements of the lower scale.</p> <p>This question explores how the organisation ensures that information management meets widely used AM practice requirements (eg, s 4.4.6 (a), (c) and (d) of PAS 55).</p> | The management team that has overall responsibility for asset management. Users of the organisational information systems. | The asset management information system, together with the policies, procedure(s), improvement initiatives and audits regarding information controls. |
|----|------------------------|--|---|--|--|--|--|---|



Company Name

Marlborough Lines Ltd

AMP Planning Period

1 April 2015 – 31 March 2025

Asset Management Standard Applied

PASS5/ISO55001

**SCHEDULE 13: REPORT ON ASSET MANAGEMENT MATURITY (cont)**

| Question No. | Function                                      | Question   | Maturity Level 0  | Maturity Level 1   | Maturity Level 2   | Maturity Level 3  | Maturity Level 4  |
|--------------|---|--|---|--|--|---|---|
| 53           | Communication, participation and consultation | How does the organisation ensure that pertinent asset management information is effectively communicated to and from employees and other stakeholders, including contracted service providers? | The organisation has not recognised the need to formally communicate any asset management information.              | There is evidence that the pertinent asset management information to be shared along with those to share it with is being determined.  | The organisation has determined pertinent information and relevant parties. Some effective two way communication is in place but as yet not all relevant parties are clear on their roles and responsibilities with respect to asset management information. | Two way communication is in place between all relevant parties, ensuring that information is effectively communicated to match the requirements of asset management strategy, plan(s) and process(es). Pertinent asset information requirements are regularly reviewed. | The organisation's process(es) surpass the standard required to comply with requirements set out in a recognised standard.<br><br>The assessor is advised to note in the Evidence section why this is the case and the evidence seen. |
| 59           | Asset Management System documentation         | What documentation has the organisation established to describe the main elements of its asset management system and interactions between them?  | The organisation has not established documentation that describes the main elements of the asset management system. | The organisation is aware of the need to put documentation in place and is in the process of determining how to document the main elements of its asset management system.   | The organisation in the process of documenting its asset management system and has documentation in place that describes some, but not all, of the main elements of its asset management system and their interaction.                                       | The organisation has established documentation that comprehensively describes all the main elements of its asset management system and the interactions between them. The documentation is kept up to date.   | The organisation's process(es) surpass the standard required to comply with requirements set out in a recognised standard.<br><br>The assessor is advised to note in the Evidence section why this is the case and the evidence seen. |
| 62           | Information management                        | What has the organisation done to determine what its asset management information system(s) should contain in order to support its asset management system?                                    | The organisation has not considered what asset management information is required.                                  | The organisation is aware of the need to determine in a structured manner what its asset information system should contain in order to support its asset management system and is in the process of deciding how to do this. | The organisation has developed a structured process to determine what its asset information system should contain in order to support its asset management system and has commenced implementation of the process.   | The organisation has determined what its asset information system should contain in order to support its asset management system. The requirements relate to the whole life cycle and cover information originating from both internal and external sources.            | The organisation's process(es) surpass the standard required to comply with requirements set out in a recognised standard.<br><br>The assessor is advised to note in the Evidence section why this is the case and the evidence seen. |

|    |                        |  |  |  |   |  |   |
|----|------------------------|--|--|--|---|--|---|
| 63 | Information management | How does the organisation maintain its asset management information system(s) and ensure that the data held within it (them) is of the requisite quality and accuracy and is consistent? | There are no formal controls in place or controls are extremely limited in scope and/or effectiveness. | The organisation is aware of the need for effective controls and is in the process of developing an appropriate control process(es). | The organisation has developed a controls that will ensure the data held is of the requisite quality and accuracy and is consistent and is in the process of implementing them. | The organisation has effective controls in place that ensure the data held is of the requisite quality and accuracy and is consistent. The controls are regularly reviewed and improved where necessary. | The organisation's process(es) surpass the standard required to comply with requirements set out in a recognised standard.<br><br>The assessor is advised to note in the Evidence section why this is the case and the evidence seen. |
|----|------------------------|--|--|--|---|--|---|

Company Name

Marlborough Lines Ltd

AMP Planning Period

1 April 2015 – 31 March 2025

Asset Management Standard Applied

PAS55/ISO55001

**SCHEDULE 13: REPORT ON ASSET MANAGEMENT MATURITY (cont)**

| Question No. | Function                                      | Question   | Score | Evidence—Summary  | User Guidance | Why   | Who  | Record/document Information  |
|--------------|---|--|-------|---|---------------|---|--|--|
| 64           | Information management                        | How has the organisation's ensured its asset management information system is relevant to its needs?   | 3     | An in depth review of the asset management information system needs has recently occurred through the implementation of new AM software. All systems used within MLL are typical to those used in other EDBs and have been selected based on their abilities to fulfil the identified needs of MLL. The AMP |               | Widely used AM standards need not be prescriptive about the form of the asset management information system, but simply require that the asset management information system is appropriate to the organisations needs, can be effectively used and can supply information which is consistent and of the requisite quality and accuracy.   | The organisation's strategic planning team. The management team that has overall responsibility for asset management. Information management team. Users of the organisational information systems.  | The documented process the organisation employs to ensure its asset management information system aligns with its asset management requirements. Minutes of information systems review meetings involving users.   |
| 69           | Risk management process(es)                   | How has the organisation documented process(es) and/or procedure(s) for the identification and assessment of asset and asset management related risks throughout the asset life cycle?                                       | 3     | Both the AMP and Emergency Preparedness plan develop a risk register and strategies to remove or reduce that risk across the lifecycle of the asset. Asset construction, maintenance and operation practices adhere to internal standards and recognised NZ standards to minimise risk.                     |               | Risk management is an important foundation for proactive asset management. Its overall purpose is to understand the cause, effect and likelihood of adverse events occurring, to optimally manage such risks to an acceptable level, and to provide an audit trail for the management of risks. Widely used standards require the organisation to have process(es) and/or procedure(s) in place that set out how the organisation identifies and assesses asset and asset management related risks. The risks have to be considered across the four phases of the asset lifecycle (eg, para 4.3.3 of PAS 55). | The top management team in conjunction with the organisation's senior risk management representatives. There may also be input from the organisation's Safety, Health and Environment team. Staff who carry out risk identification and assessment.                          | The organisation's risk management framework and/or evidence of specific process(es) and/or procedure(s) that deal with risk control mechanisms. Evidence that the process(es) and/or procedure(s) are implemented across the business and maintained. Evidence of agendas and minutes from risk management meetings. Evidence of feedback in to process(es) and/or procedure(s) as a result of incident investigation(s). Risk registers and assessments. |
| 79           | Use and maintenance of asset risk information | How does the organisation ensure that the results of risk assessments provide input into the identification of adequate resources and training and competency needs?   | 2     | Risk treatment/mitigation strategies are developed in the AMP, which in turn determines resources required to perform. This is a key driver in determining the key resources, training and competencies for MLL staff.  |               | Widely used AM standards require that the output from risk assessments are considered and that adequate resource (including staff) and training is identified to match the requirements. It is a further requirement that the effects of the control measures are considered, as there may be implications in resources and training required to achieve other objectives.  | Staff responsible for risk assessment and those responsible for developing and approving resource and training plan(s). There may also be input from the organisation's Safety, Health and Environment team.   | The organisations risk management framework. The organisation's resourcing plan(s) and training and competency plan(s). The organisation should be able to demonstrate appropriate linkages between the content of resource plan(s) and training and competency plan(s) to the risk assessments and risk control measures that have been developed.  |
| 82           | Legal and other requirements                  | What procedure does the organisation have to identify and provide access to its legal, regulatory, statutory and other asset management requirements, and how is requirements incorporated into the asset management system? | 3     | Top level management staff have regular communication with ComCom, EEA and ENA as well as receiving various publications from consultants. Existing legislation and legislative changes are key drivers in AM planning.   |               | In order for an organisation to comply with its legal, regulatory, statutory and other asset management requirements, the organisation first needs to ensure that it knows what they are (eg, PAS 55 specifies this in s 4.4.8). It is necessary to have systematic and auditable mechanisms in place to identify new and changing requirements. Widely used AM standards also require that requirements are incorporated into the asset management system (e.g. procedure(s) and process(es))  | Top management. The organisations regulatory team. The organisation's legal team or advisors. The management team with overall responsibility for the asset management system. The organisation's health and safety team or advisors. The organisation's policy making team. | The organisational processes and procedures for ensuring information of this type is identified, made accessible to those requiring the information and is incorporated into asset management strategy and objectives  |

Company Name

Marlborough Lines Ltd

AMP Planning Period

1 April 2015 – 31 March 2025

Asset Management Standard Applied

PASS5/ISO55001

**SCHEDULE 13: REPORT ON ASSET MANAGEMENT MATURITY (cont)**

| Question No. | Function                                      | Question   | Maturity Level 0  | Maturity Level 1  | Maturity Level 2   | Maturity Level 3  | Maturity Level 4  |
|--------------|---|--|---|---|--|---|---|
| 64           | Information management                        | How has the organisation's ensured its asset management information system is relevant to its needs?   | The organisation has not considered the need to determine the relevance of its management information system. At present there are major gaps between what the information system provides and the organisations needs. | The organisation understands the need to ensure its asset management information system is relevant to its needs and is determining an appropriate means by which it will achieve this. At present there are significant gaps between what the information system provides and the organisations needs. | The organisation has developed and is implementing a process to ensure its asset management information system is relevant to its needs. Gaps between what the information system provides and the organisations needs have been identified and action is being taken to close them. | The organisation's asset management information system aligns with its asset management requirements. Users can confirm that it is relevant to their needs.   | The organisation's process(es) surpass the standard required to comply with requirements set out in a recognised standard.<br><br>The assessor is advised to note in the Evidence section why this is the case and the evidence seen. |
| 69           | Risk management process(es)                   | How has the organisation documented process(es) and/or procedure(s) for the identification and assessment of asset and asset management related risks throughout the asset life cycle?                                       | The organisation has not considered the need to document process(es) and/or procedure(s) for the identification and assessment of asset and asset management related risks throughout the asset life cycle.             | The organisation is aware of the need to document the management of asset related risk across the asset lifecycle. The organisation has plan(s) to formally document all relevant process(es) and procedure(s) or has already commenced this activity.  | The organisation is in the process of documenting the identification and assessment of asset related risk across the asset lifecycle but it is incomplete or there are inconsistencies between approaches and a lack of integration.   | Identification and assessment of asset related risk across the asset lifecycle is fully documented. The organisation can demonstrate that appropriate documented mechanisms are integrated across life cycle phases and are being consistently applied. | The organisation's process(es) surpass the standard required to comply with requirements set out in a recognised standard.<br><br>The assessor is advised to note in the Evidence section why this is the case and the evidence seen. |
| 79           | Use and maintenance of asset risk information | How does the organisation ensure that the results of risk assessments provide input into the identification of adequate resources and training and competency needs?   | The organisation has not considered the need to conduct risk assessments.   | The organisation is aware of the need to consider the results of risk assessments and effects of risk control measures to provide input into reviews of resources, training and competency needs. Current input is typically ad-hoc and reactive.   | The organisation is in the process ensuring that outputs of risk assessment are included in developing requirements for resources and training. The implementation is incomplete and there are gaps and inconsistencies.   | Outputs from risk assessments are consistently and systematically used as inputs to develop resources, training and competency requirements. Examples and evidence is available.  | The organisation's process(es) surpass the standard required to comply with requirements set out in a recognised standard.<br><br>The assessor is advised to note in the Evidence section why this is the case and the evidence seen. |
| 82           | Legal and other requirements                  | What procedure does the organisation have to identify and provide access to its legal, regulatory, statutory and other asset management requirements, and how is requirements incorporated into the asset management system? | The organisation has not considered the need to identify its legal, regulatory, statutory and other asset management requirements.  | The organisation identifies some its legal, regulatory, statutory and other asset management requirements, but this is done in an ad-hoc manner in the absence of a procedure.  | The organisation has procedure(s) to identify its legal, regulatory, statutory and other asset management requirements, but the information is not kept up to date, inadequate or inconsistently managed.  | Evidence exists to demonstrate that the organisation's legal, regulatory, statutory and other asset management requirements are identified and kept up to date. Systematic mechanisms for identifying relevant legal and statutory requirements.        | The organisation's process(es) surpass the standard required to comply with requirements set out in a recognised standard.<br><br>The assessor is advised to note in the Evidence section why this is the case and the evidence seen. |

Company Name

Marlborough Lines Ltd

AMP Planning Period

1 April 2015 – 31 March 2025

Asset Management Standard Applied

PAS55/ISO55001

**SCHEDULE 13: REPORT ON ASSET MANAGEMENT MATURITY (cont)**

| Question No. | Function                             | Question   | Score | Evidence—Summary  | User Guidance | Why  | Who  | Record/document Information  |
|--------------|--------------------------------------|--|-------|---|---------------|--|--|--|
| 88           | Life Cycle Activities                | How does the organisation establish implement and maintain process(es) for the implementation of its asset management plan(s) and control of activities across the creation, acquisition or enhancement of assets. This includes design, modification, procurement, construction and commissioning activities?   | 3     | The Network Design & Construction Standards sets minimum standards for the selection of design concepts, detail design features, selection of materials, and construction. ML Store procurement policies highlight preferred suppliers that have met acceptable standards for specified materials, thus eliminating the risk of non-compliant equipment or components. <i>Business activities such as</i> |               | Life cycle activities are about the implementation of asset management plan(s) i.e. they are the "doing" phase. They need to be done effectively and well in order for asset management to have any practical meaning. As a consequence, widely used standards (eg, PAS 55 s 4.5.1) require organisations to have in place appropriate process(es) and procedure(s) for the implementation of asset management plan(s) and control of lifecycle activities. This question explores those aspects relevant to asset creation.   | Asset managers, design staff, construction staff and project managers from other impacted areas of the business, e.g. Procurement  | Documented process(es) and procedure(s) which are relevant to demonstrating the effective management and control of life cycle activities during asset creation, acquisition, enhancement including design, modification, procurement, construction and commissioning.   |
| 91           | Life Cycle Activities                | How does the organisation ensure that process(es) and/or procedure(s) for the implementation of asset management plan(s) and control of activities during maintenance (and inspection) of assets are sufficient to ensure activities are carried out under specified conditions, are consistent with asset management strategy and control cost, risk and performance? | 2     | Almost all of MLL's maintenance work is performed in-house, in adherence to MLL standards. MLL is in the process of developing a Maintenance Standard which declares the required maintenance periods and maintenance tasks per asset type across its lifecycle.  |               | Having documented process(es) which ensure the asset management plan(s) are implemented in accordance with any specified conditions, in a manner consistent with the asset management policy, strategy and objectives and in such a way that cost, risk and asset system performance are appropriately controlled is critical. They are an essential part of turning intention into action (eg, as required by PAS 55 s 4.5.1).  | Asset managers, operations managers, maintenance managers and project managers from other impacted areas of the business   | Documented procedure for review. Documented procedure for audit of process delivery. Records of previous audits, improvement actions and documented confirmation that actions have been carried out.   |
| 95           | Performance and condition monitoring | How does the organisation measure the performance and condition of its assets?   | 3     | Asset performance and condition is monitored through regular inspections and testing (where applicable). This is performed by both ML Contracting and external contractors. Failure of in-service assets is monitored through the control room, with serious failures/faults assessed by engineering staff to identify causes of failure and act accordingly.   |               | Widely used AM standards require that organisations establish implement and maintain procedure(s) to monitor and measure the performance and/or condition of assets and asset systems. They further set out requirements in some detail for reactive and proactive monitoring, and leading/lagging performance indicators together with the monitoring or results to provide input to corrective actions and continual improvement. There is an expectation that performance and condition monitoring will provide input to improving asset management strategy, objectives and plan(s). | A broad cross-section of the people involved in the organisation's asset-related activities from data input to decision-makers, i.e. an end-to-end assessment. This should include contactors and other relevant third parties as appropriate. | Functional policy and/or strategy documents for performance or condition monitoring and measurement. The organisation's performance monitoring frameworks, balanced scorecards etc. Evidence of the reviews of any appropriate performance indicators and the action lists resulting from these reviews. Reports and trend analysis using performance and condition information. Evidence of the use of performance and condition information shaping improvements and supporting asset management strategy, objectives and plan(s). |

|    |  |   |   |  |  |  |  |   |
|----|--|---|---|--|--|--|--|---|
| 99 | Investigation of asset-related failures, incidents and nonconformities | How does the organisation ensure responsibility and the authority for the handling, investigation and mitigation of asset-related failures, incidents and emergency situations and non conformances is clear, unambiguous, understood and communicated? | 2 | The control room/dispatch staff are the first level of response to an asset related failure, and are responsible for making the situation safe/repair where possible. The AMP declares responsibility for the handling and investigation of asset failures, incidents and emergency situations. These are clearly understood by all AM staff at MLL. |  | Widely used AM standards require that the organisation establishes implements and maintains process(es) for the handling and investigation of failures incidents and non-conformities for assets and sets down a number of expectations. Specifically this question examines the requirement to define clearly responsibilities and authorities for these activities, and communicate these unambiguously to relevant people including external stakeholders if appropriate. | The organisation's safety and environment management team. The team with overall responsibility for the management of the assets. People who have appointed roles within the asset-related investigation procedure, from those who carry out the investigations to senior management who review the recommendations. Operational controllers responsible for managing the asset base under fault conditions and maintaining services to consumers. Contractors and other third parties as appropriate. | Process(es) and procedure(s) for the handling, investigation and mitigation of asset-related failures, incidents and emergency situations and non conformances. Documentation of assigned responsibilities and authority to employees. Job Descriptions, Audit reports. Common communication systems i.e. all Job Descriptions on Internet etc. |
|----|--|---|---|--|--|--|--|---|

Company Name

Marlborough Lines Ltd

AMP Planning Period

1 April 2015 – 31 March 2025

Asset Management Standard Applied

PASS5/ISO55001

**SCHEDULE 13: REPORT ON ASSET MANAGEMENT MATURITY (cont)**

| Question No. | Function                             | Question   | Maturity Level 0  | Maturity Level 1   | Maturity Level 2  | Maturity Level 3  | Maturity Level 4  |
|--------------|--------------------------------------|--|---|--|---|---|---|
| 88           | Life Cycle Activities                | How does the organisation establish implement and maintain process(es) for the implementation of its asset management plan(s) and control of activities across the creation, acquisition or enhancement of assets. This includes design, modification, procurement, construction and commissioning activities?   | The organisation does not have process(es) in place to manage and control the implementation of asset management plan(s) during activities related to asset creation including design, modification, procurement, construction and commissioning. | The organisation is aware of the need to have process(es) and procedure(s) in place to manage and control the implementation of asset management plan(s) during activities related to asset creation including design, modification, procurement, construction and commissioning but currently do not have these in place (note: procedure(s) may exist but they are inconsistent/incomplete). | The organisation is in the process of putting in place process(es) and procedure(s) to manage and control the implementation of asset management plan(s) during activities related to asset creation including design, modification, procurement, construction and commissioning. Gaps and inconsistencies are being addressed. | Effective process(es) and procedure(s) are in place to manage and control the implementation of asset management plan(s) during activities related to asset creation including design, modification, procurement, construction and commissioning.   | The organisation's process(es) surpass the standard required to comply with requirements set out in a recognised standard.<br><br>The assessor is advised to note in the Evidence section why this is the case and the evidence seen. |
| 91           | Life Cycle Activities                | How does the organisation ensure that process(es) and/or procedure(s) for the implementation of asset management plan(s) and control of activities during maintenance (and inspection) of assets are sufficient to ensure activities are carried out under specified conditions, are consistent with asset management strategy and control cost, risk and performance? | The organisation does not have process(es)/procedure(s) in place to control or manage the implementation of asset management plan(s) during this life cycle phase.  | The organisation is aware of the need to have process(es) and procedure(s) in place to manage and control the implementation of asset management plan(s) during this life cycle phase but currently do not have these in place and/or there is no mechanism for confirming they are effective and where needed modifying them.   | The organisation is in the process of putting in place process(es) and procedure(s) to manage and control the implementation of asset management plan(s) during this life cycle phase. They include a process for confirming the process(es)/procedure(s) are effective and if necessary carrying out modifications.            | The organisation has in place process(es) and procedure(s) to manage and control the implementation of asset management plan(s) during this life cycle phase. They include a process, which is itself regularly reviewed to ensure it is effective, for confirming the process(es)/ procedure(s) are effective and if necessary carrying out modifications. | The organisation's process(es) surpass the standard required to comply with requirements set out in a recognised standard.<br><br>The assessor is advised to note in the Evidence section why this is the case and the evidence seen. |
| 95           | Performance and condition monitoring | How does the organisation measure the performance and condition of its assets?   | The organisation has not considered how to monitor the performance and condition of its assets.   | The organisation recognises the need for monitoring asset performance but has not developed a coherent approach. Measures are incomplete, predominantly reactive and lagging. There is no linkage to asset management objectives.  | The organisation is developing coherent asset performance monitoring linked to asset management objectives. Reactive and proactive measures are in place. Use is being made of leading indicators and analysis. Gaps and inconsistencies remain.  | Consistent asset performance monitoring linked to asset management objectives is in place and universally used including reactive and proactive measures. Data quality management and review process are appropriate. Evidence of leading indicators and analysis.  | The organisation's process(es) surpass the standard required to comply with requirements set out in a recognised standard.<br><br>The assessor is advised to note in the Evidence section why this is the case and the evidence seen. |

|    |  |   |  |  |  |  |   |
|----|--|---|--|--|--|--|---|
| 99 | Investigation of asset-related failures, incidents and nonconformities | How does the organisation ensure responsibility and the authority for the handling, investigation and mitigation of asset-related failures, incidents and emergency situations and non conformances is clear, unambiguous, understood and communicated? | The organisation has not considered the need to define the appropriate responsibilities and the authorities. | The organisation understands the requirements and is in the process of determining how to define them. | The organisation are in the process of defining the responsibilities and authorities with evidence. Alternatively there are some gaps or inconsistencies in the identified responsibilities/authorities. | The organisation have defined the appropriate responsibilities and authorities and evidence is available to show that these are applied across the business and kept up to date. | The organisation's process(es) surpass the standard required to comply with requirements set out in a recognised standard.<br><br>The assessor is advised to note in the Evidence section why this is the case and the evidence seen. |
|----|--|---|--|--|--|--|---|



Company Name

Marlborough Lines Ltd

AMP Planning Period

1 April 2015 – 31 March 2025

Asset Management Standard Applied

PAS55/ISO55001

**SCHEDULE 13: REPORT ON ASSET MANAGEMENT MATURITY (cont)**

| Question No. | Function                         | Question  | Score | Evidence—Summary  | User Guidance | Why  | Who   | Record/document Information  |
|--------------|----------------------------------|---|-------|---|---------------|--|---|--|
| 105          | Audit                            | What has the organisation done to establish procedure(s) for the audit of its asset management system (process(es))?  | 2     | MLL undergoes regular internal and external auditing for all major compliance standards that the company has been accredited with (ISO 9001, ISO 14001, ISO 18001 and NZS 7901) which include AM systems. The SCI is approved by the trust and is a major accountability mechanism.   |               | This question seeks to explore what the organisation has done to comply with the standard practice AM audit requirements (eg, the associated requirements of PAS 55 s 4.6.4 and its linkages to s 4.7).  | The management team responsible for its asset management procedure(s). The team with overall responsibility for the management of the assets. Audit teams, together with key staff responsible for asset management. For example, Asset Management Director, Engineering Director. People with responsibility for carrying out risk assessments | The organisation's asset-related audit procedure(s). The organisation's methodology(s) by which it determined the scope and frequency of the audits and the criteria by which it identified the appropriate audit personnel. Audit schedules, reports etc. Evidence of the procedure(s) by which the audit results are presented, together with any subsequent communications. The risk assessment schedule or risk registers. |
| 109          | Corrective & Preventative action | How does the organisation instigate appropriate corrective and/or preventive actions to eliminate or prevent the causes of identified poor performance and non conformance?                                 | 3     | All network faults are managed by the control room, and appropriate measures taken to restore the network to normal as fast as possible. Each fault is investigated to identify the cause of failure and findings are reported to engineering staff. Significant concerns or recurring trends are then investigated further to remove the risk of future failure. Network reliability is a key driver in AM planning. |               | Having investigated asset related failures, incidents and non-conformances, and taken action to mitigate their consequences, an organisation is required to implement preventative and corrective actions to address root causes. Incident and failure investigations are only useful if appropriate actions are taken as a result to assess changes to a businesses risk profile and ensure that appropriate arrangements are in place should a recurrence of the incident happen. Widely used AM standards also require that necessary changes arising from preventive or corrective action are made to the asset management system. | The management team responsible for its asset management procedure(s). The team with overall responsibility for the management of the assets. Audit and incident investigation teams. Staff responsible for planning and managing corrective and preventive actions.  | Analysis records, meeting notes and minutes, modification records. Asset management plan(s), investigation reports, audit reports, improvement programmes and projects. Recorded changes to asset management procedure(s) and process(es). Condition and performance reviews. Maintenance reviews  |
| 113          | Continual Improvement            | How does the organisation achieve continual improvement in the optimal combination of costs, asset related risks and the performance and condition of assets and asset systems across the whole life cycle? | 2     | Asset performance, associated risk and operational costs are the major considerations during network planning. Attention is given to the maintenance on a condition basis as opposed to time based. Annual customer surveys are performed to ensure network performance is aligned with consumer expectations. Continual improvement is a core element of ISO9001 .   |               | Widely used AM standards have requirements to establish, implement and maintain process(es)/procedure(s) for identifying, assessing, prioritising and implementing actions to achieve continual improvement. Specifically there is a requirement to demonstrate continual improvement in optimisation of cost risk and performance/condition of assets across the life cycle. This question explores an organisation's capabilities in this area—looking for systematic improvement mechanisms rather than reviews and audit (which are separately examined).  | The top management of the organisation. The manager/team responsible for managing the organisation's asset management system, including its continual improvement. Managers responsible for policy development and implementation.  | Records showing systematic exploration of improvement. Evidence of new techniques being explored and implemented. Changes in procedure(s) and process(es) reflecting improved use of optimisation tools/techniques and available information. Evidence of working parties and research.  |

|     |                       |   |   |   |  |   |  |   |
|-----|-----------------------|---|---|---|--|---|--|---|
| 115 | Continual Improvement | How does the organisation seek and acquire knowledge about new asset management related technology and practices, and evaluate their potential benefit to the organisation? | 3 | AM staff regularly attend industry conferences and tradeshows to witness and review recent industry developments. Subscription to industry publications as well as regular interaction between MLL and other EDBs, assist in acquiring knowledge of improved technology and practices relating to Asset Management. |  | One important aspect of continual improvement is where an organisation looks beyond its existing boundaries and knowledge base to look at what 'new things are on the market'. These new things can include equipment, process(es), tools, etc. An organisation which does this (eg, by the PAS 55 s 4.6 standards) will be able to demonstrate that it continually seeks to expand its knowledge of all things affecting its asset management approach and capabilities. The organisation will be able to demonstrate that it identifies any such opportunities to improve, evaluates them for suitability to its own organisation and implements them as appropriate. This question explores an organisation's approach to this activity. | The top management of the organisation. The manager/team responsible for managing the organisation's asset management system, including its continual improvement. People who monitor the various items that require monitoring for 'change'. People that implement changes to the organisation's policy, strategy, etc. People within an organisation with responsibility for investigating, evaluating, recommending and implementing new tools and techniques, etc. | Research and development projects and records, benchmarking and participation knowledge exchange professional forums. Evidence of correspondence relating to knowledge acquisition. Examples of change implementation and evaluation of new tools, and techniques linked to asset management strategy and objectives. |
|-----|-----------------------|---|---|---|--|---|--|---|

Company Name

Marlborough Lines Ltd

AMP Planning Period

1 April 2015 – 31 March 2025

Asset Management Standard Applied

PASS5/ISO55001

**SCHEDULE 13: REPORT ON ASSET MANAGEMENT MATURITY (cont)**

| Question No. | Function                         | Question  | Maturity Level 0  | Maturity Level 1   | Maturity Level 2  | Maturity Level 3   | Maturity Level 4  |
|--------------|----------------------------------|---|---|--|---|--|---|
| 105          | Audit                            | What has the organisation done to establish procedure(s) for the audit of its asset management system (process(es))?  | The organisation has not recognised the need to establish procedure(s) for the audit of its asset management system.            | The organisation understands the need for audit procedure(s) and is determining the appropriate scope, frequency and methodology(s).   | The organisation is establishing its audit procedure(s) but they do not yet cover all the appropriate asset-related activities.   | The organisation can demonstrate that its audit procedure(s) cover all the appropriate asset-related activities and the associated reporting of audit results. Audits are to an appropriate level of detail and consistently managed.      | The organisation's process(es) surpass the standard required to comply with requirements set out in a recognised standard.<br><br>The assessor is advised to note in the Evidence section why this is the case and the evidence seen. |
| 109          | Corrective & Preventative action | How does the organisation instigate appropriate corrective and/or preventive actions to eliminate or prevent the causes of identified poor performance and non conformance?                                 | The organisation does not recognise the need to have systematic approaches to instigating corrective or preventive actions.     | The organisation recognises the need to have systematic approaches to instigating corrective or preventive actions. There is ad-hoc implementation for corrective actions to address failures of assets but not the asset management system. | The need is recognized for systematic instigation of preventive and corrective actions to address root causes of non compliance or incidents identified by investigations, compliance evaluation or audit. It is only partially or inconsistently in place. | Mechanisms are consistently in place and effective for the systematic instigation of preventive and corrective actions to address root causes of non compliance or incidents identified by investigations, compliance evaluation or audit. | The organisation's process(es) surpass the standard required to comply with requirements set out in a recognised standard.<br><br>The assessor is advised to note in the Evidence section why this is the case and the evidence seen. |
| 113          | Continual Improvement            | How does the organisation achieve continual improvement in the optimal combination of costs, asset related risks and the performance and condition of assets and asset systems across the whole life cycle? | The organisation does not consider continual improvement of these factors to be a requirement, or has not considered the issue. | A Continual Improvement ethos is recognised as beneficial, however it has just been started, and or covers partially the asset drivers.  | Continuous improvement process(es) are set out and include consideration of cost risk, performance and condition for assets managed across the whole life cycle but it is not yet being systematically applied.   | There is evidence to show that continuous improvement process(es) which include consideration of cost risk, performance and condition for assets managed across the whole life cycle are being systematically applied.                     | The organisation's process(es) surpass the standard required to comply with requirements set out in a recognised standard.<br><br>The assessor is advised to note in the Evidence section why this is the case and the evidence seen. |

|     |                       |   |   |  |  |  |   |
|-----|-----------------------|---|---|--|--|--|---|
| 115 | Continual Improvement | How does the organisation seek and acquire knowledge about new asset management related technology and practices, and evaluate their potential benefit to the organisation? | The organisation makes no attempt to seek knowledge about new asset management related technology or practices. | The organisation is inward looking, however it recognises that asset management is not sector specific and other sectors have developed good practice and new ideas that could apply. Ad-hoc approach. | The organisation has initiated asset management communication within sector to share and, or identify 'new' to sector asset management practices and seeks to evaluate them. | The organisation actively engages internally and externally with other asset management practitioners, professional bodies and relevant conferences. Actively investigates and evaluates new practices and evolves its asset management activities using appropriate developments. | The organisation's process(es) surpass the standard required to comply with requirements set out in a recognised standard.<br><br>The assessor is advised to note in the Evidence section why this is the case and the evidence seen. |
|-----|-----------------------|---|---|--|--|--|---|

## D Zone Substation Loadings

The following graphs show the actual zone substation loadings during 2012:

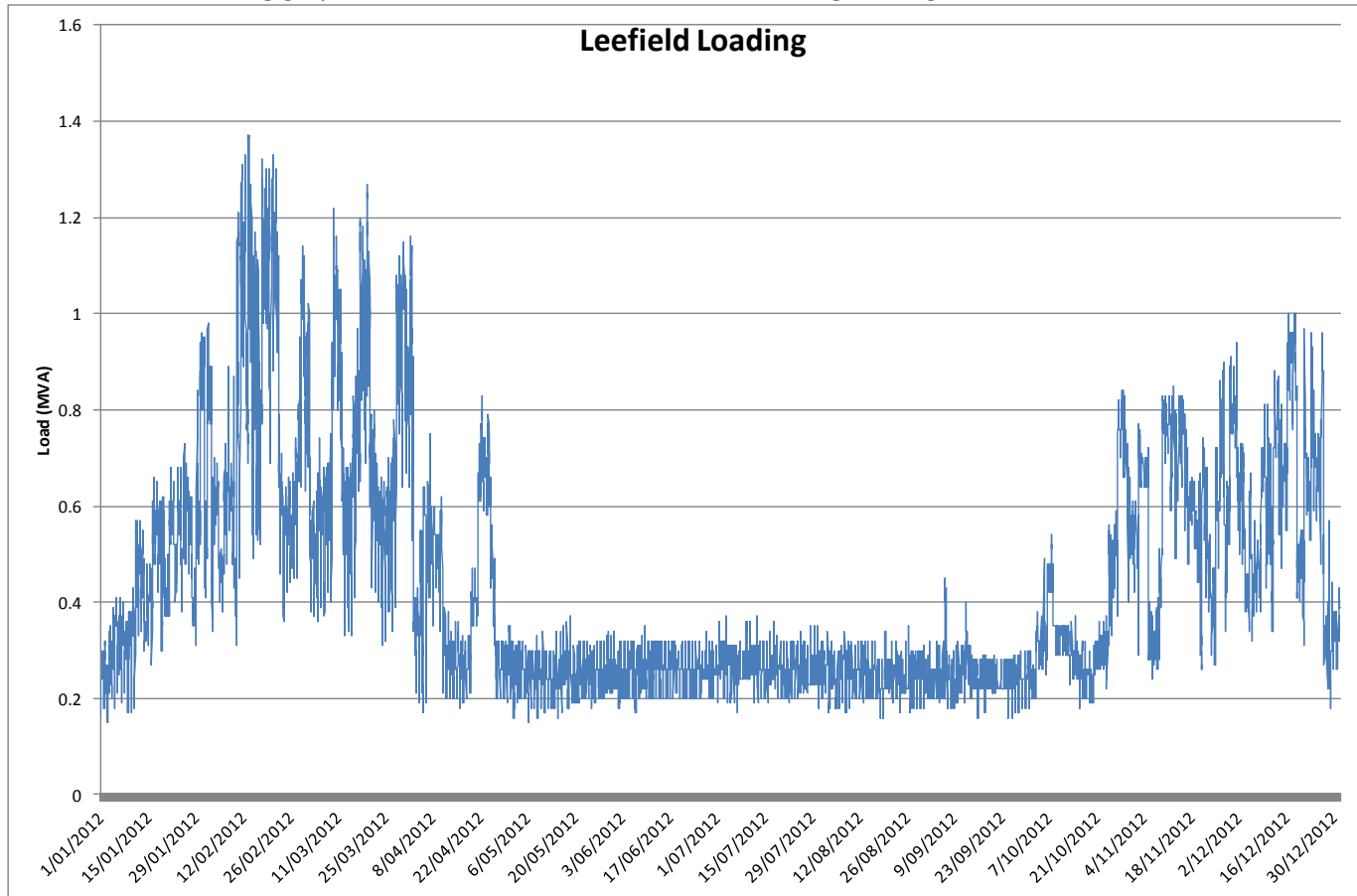

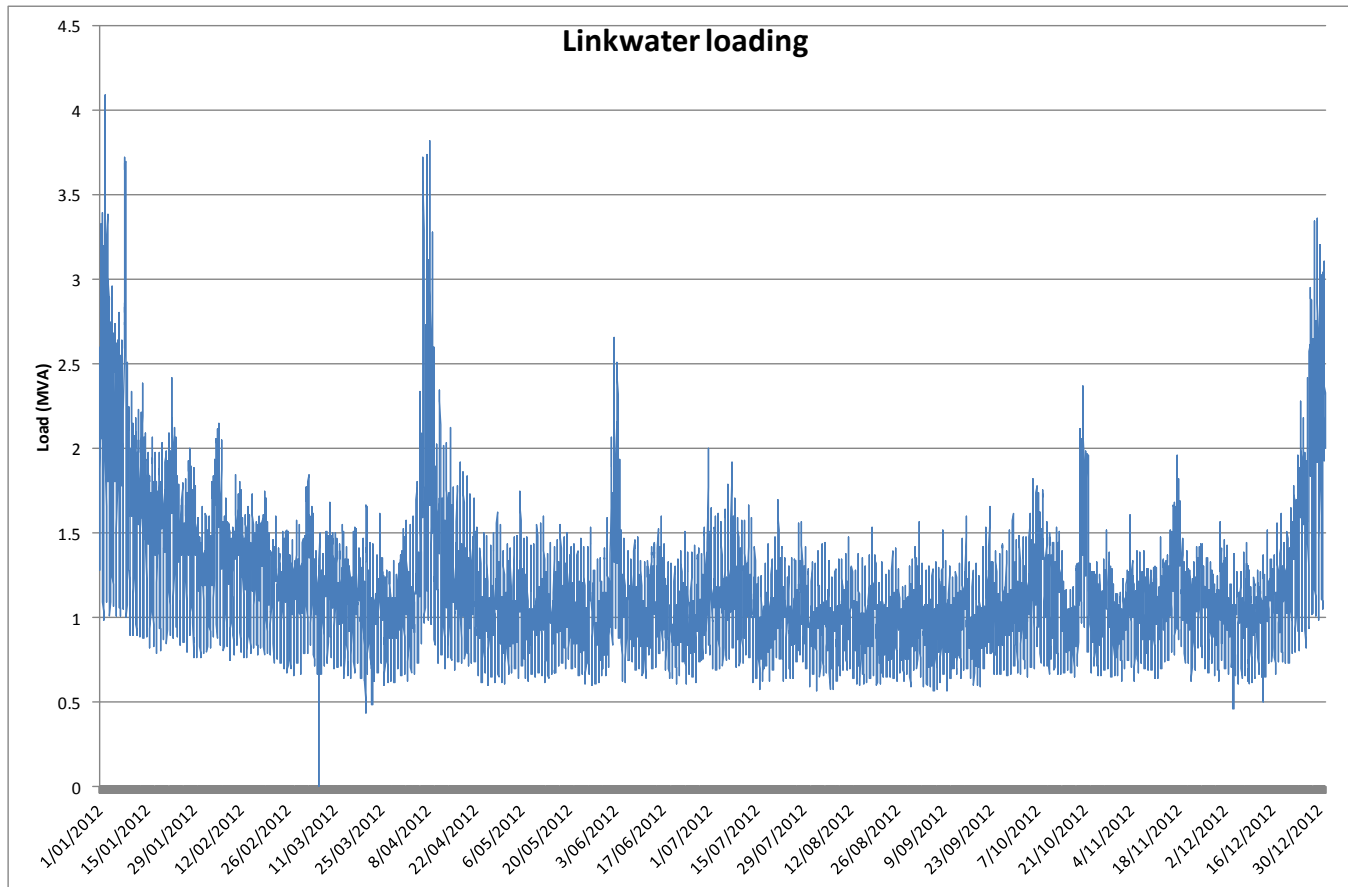

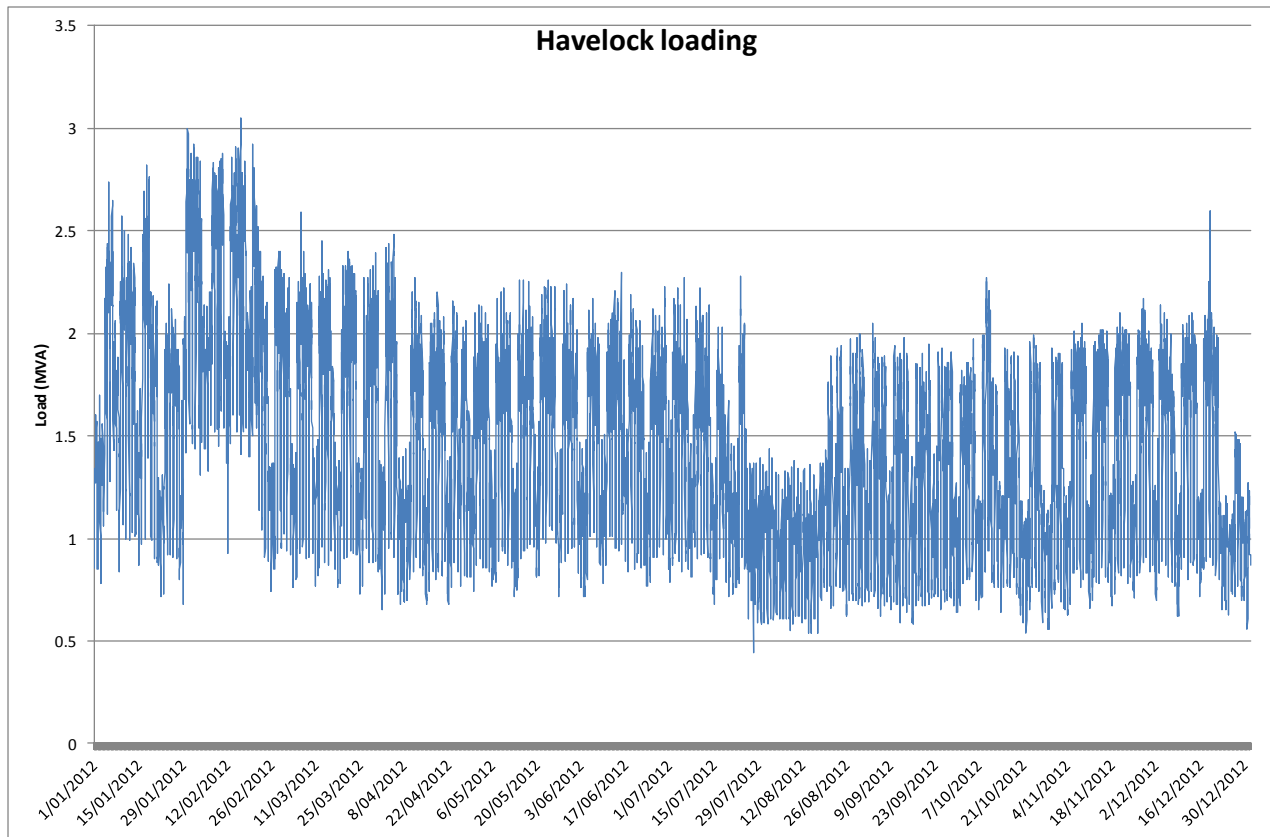

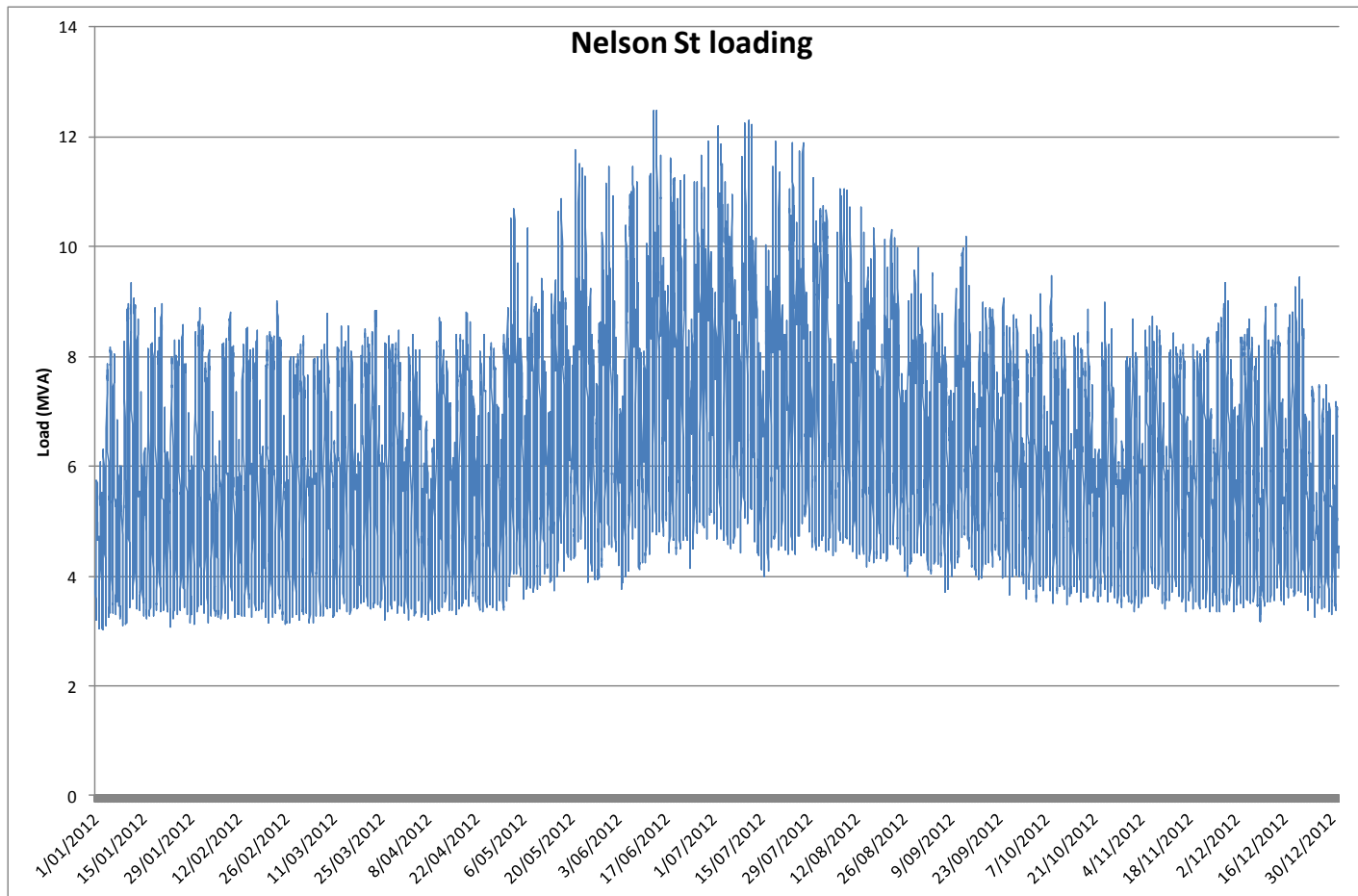



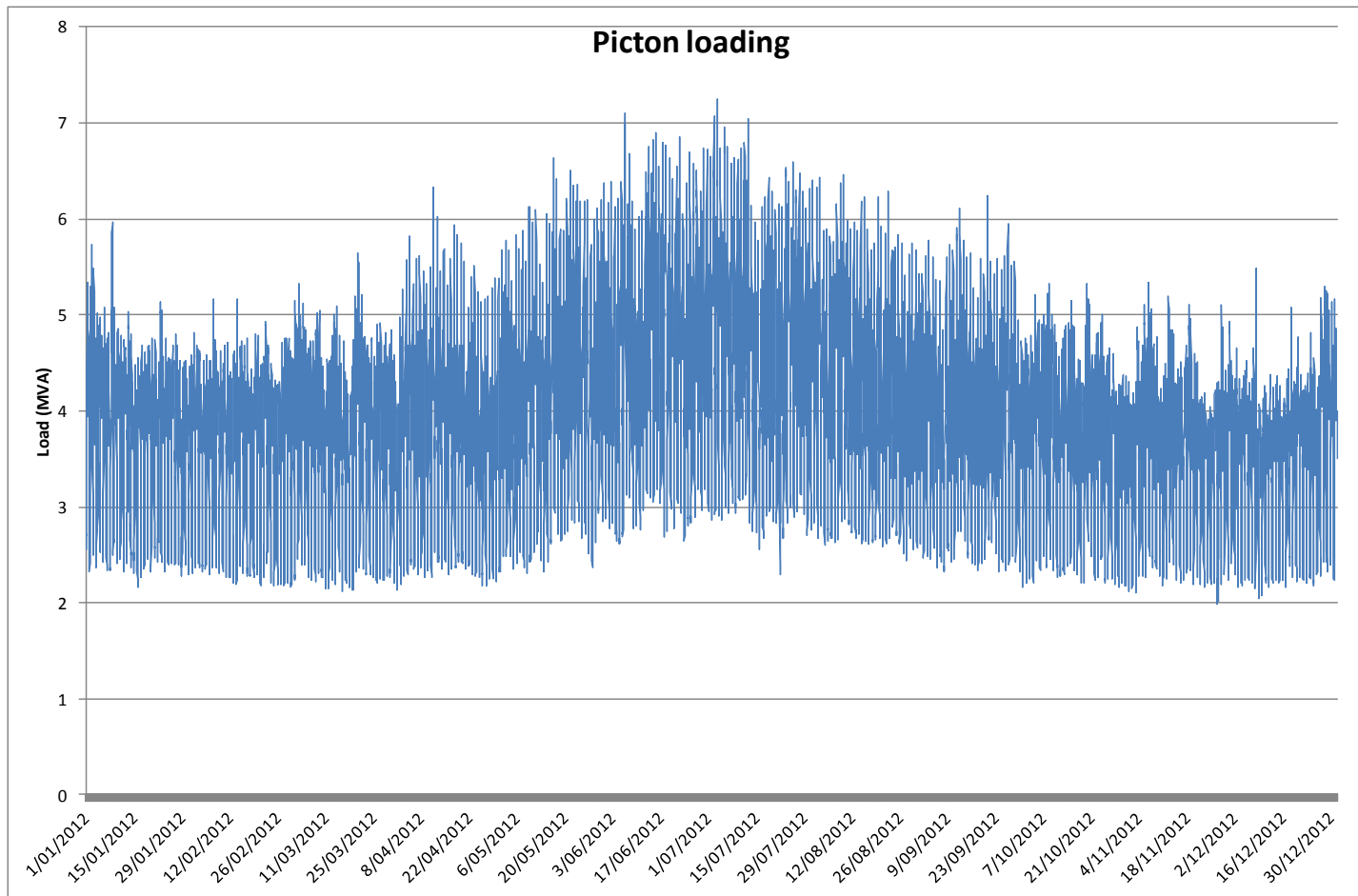

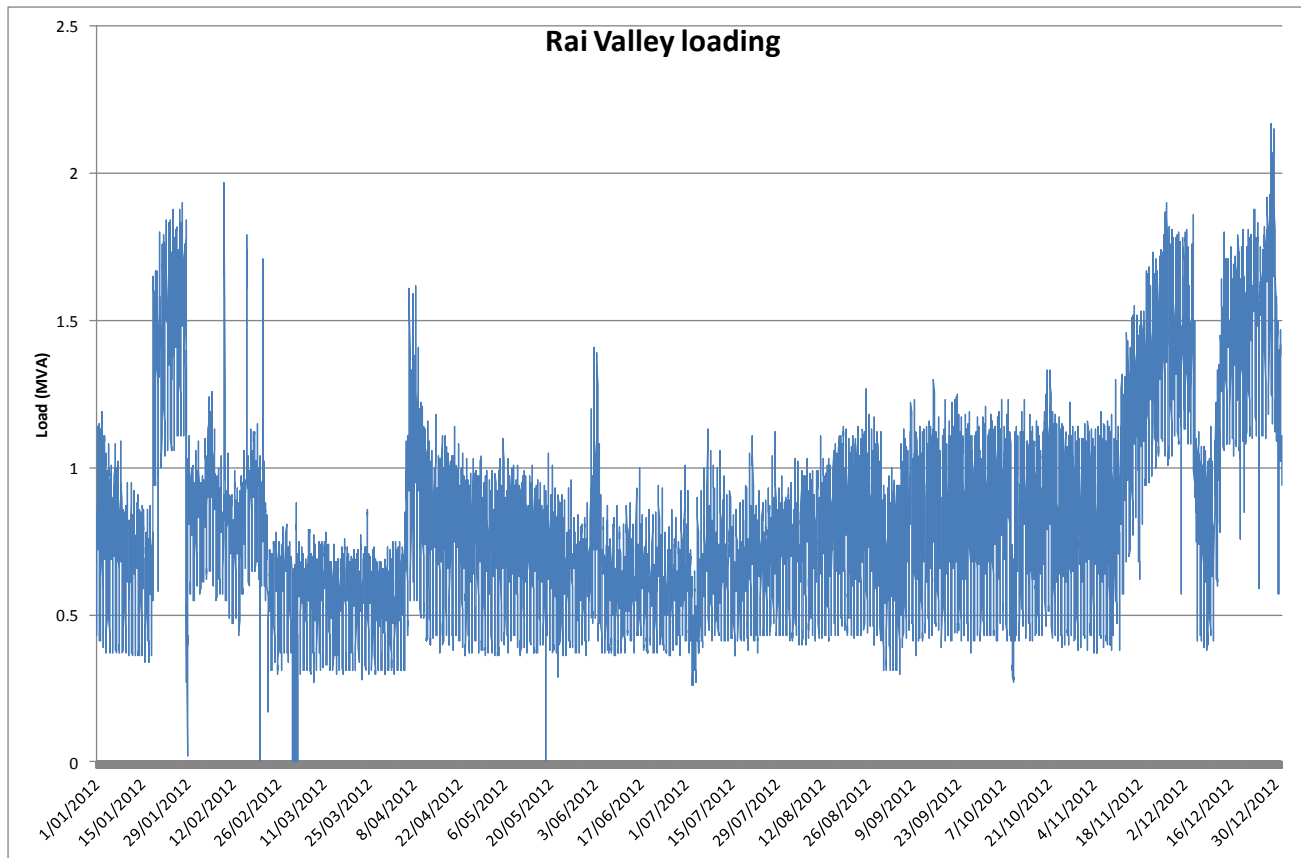

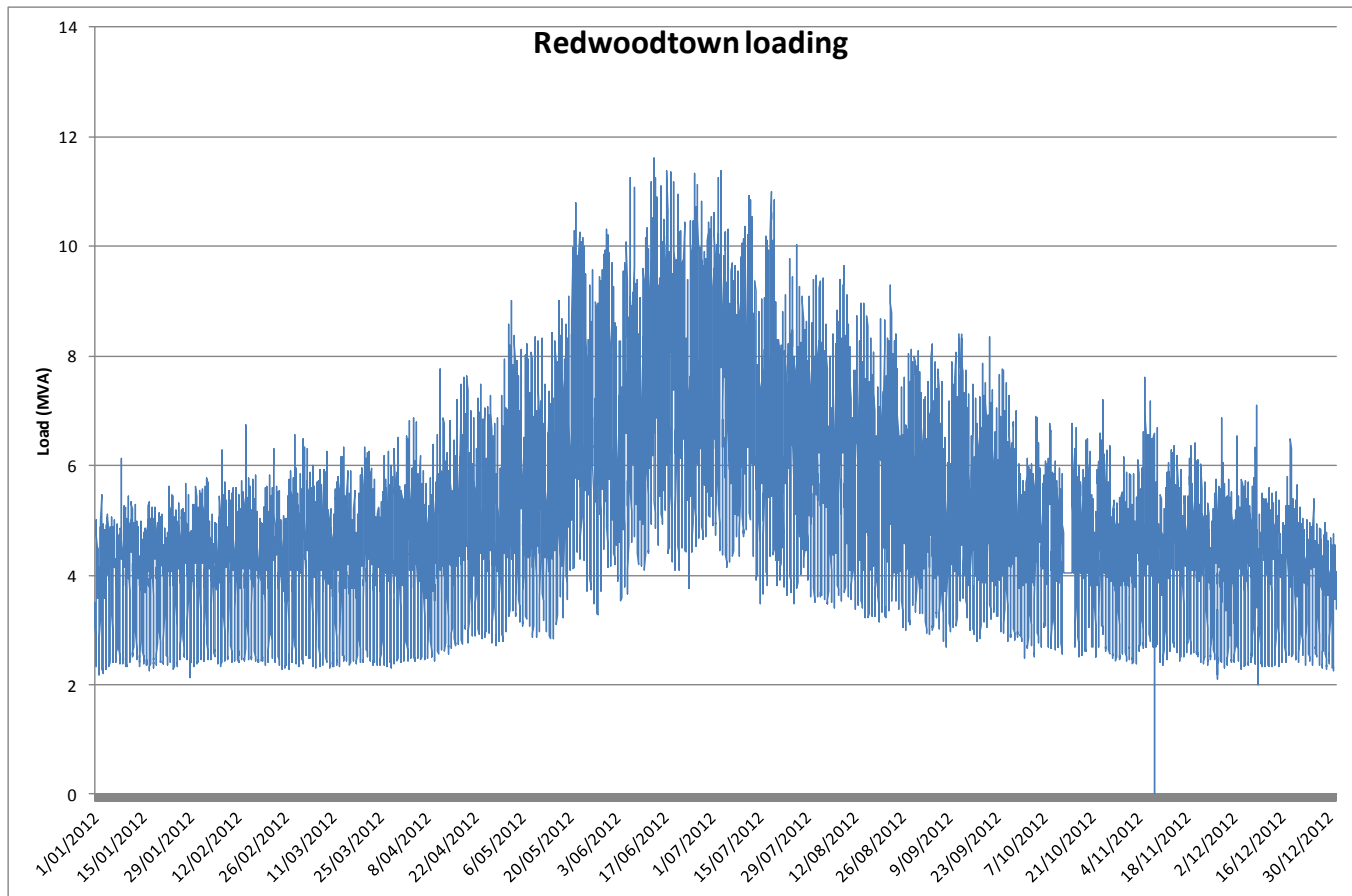

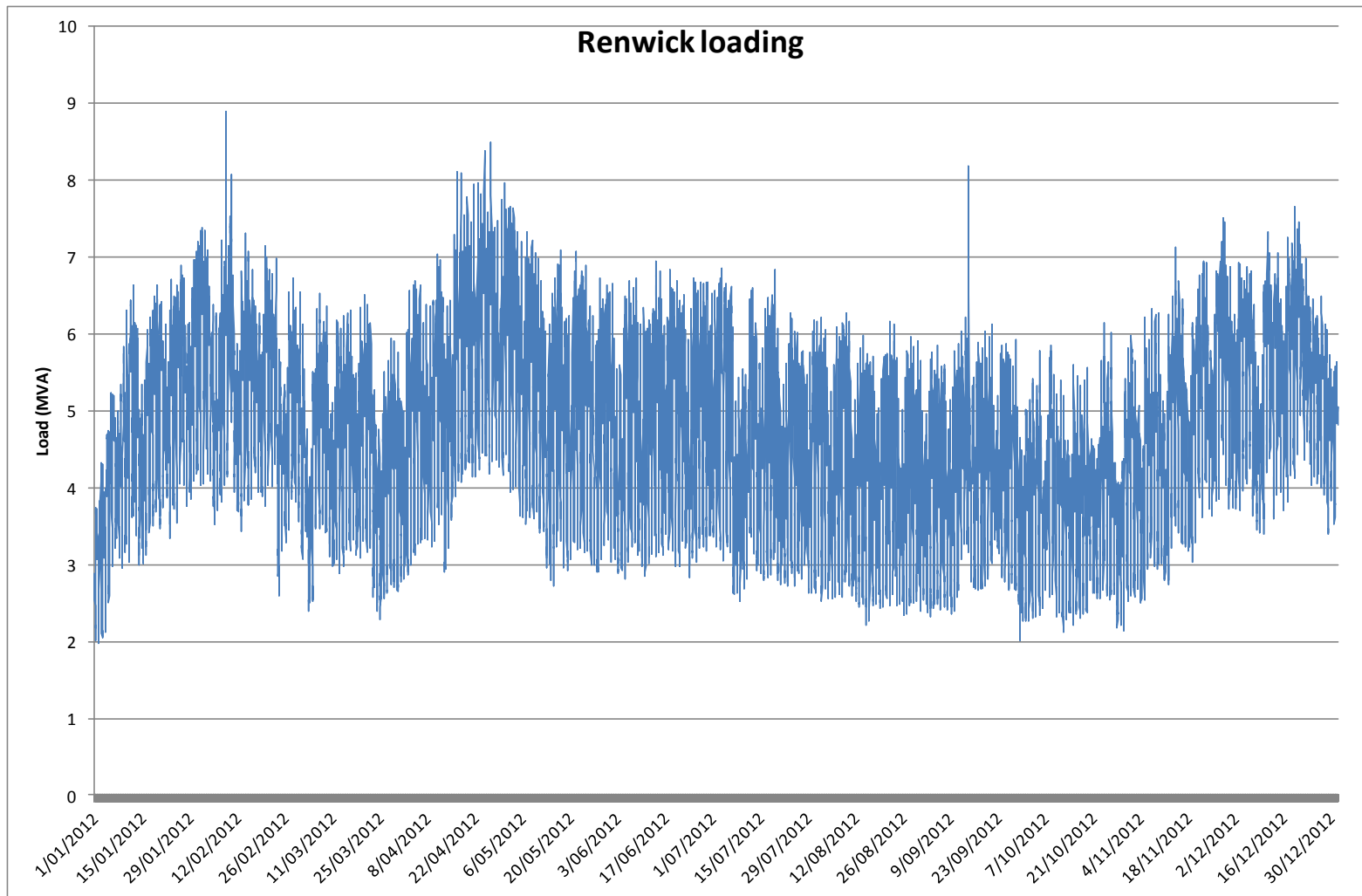

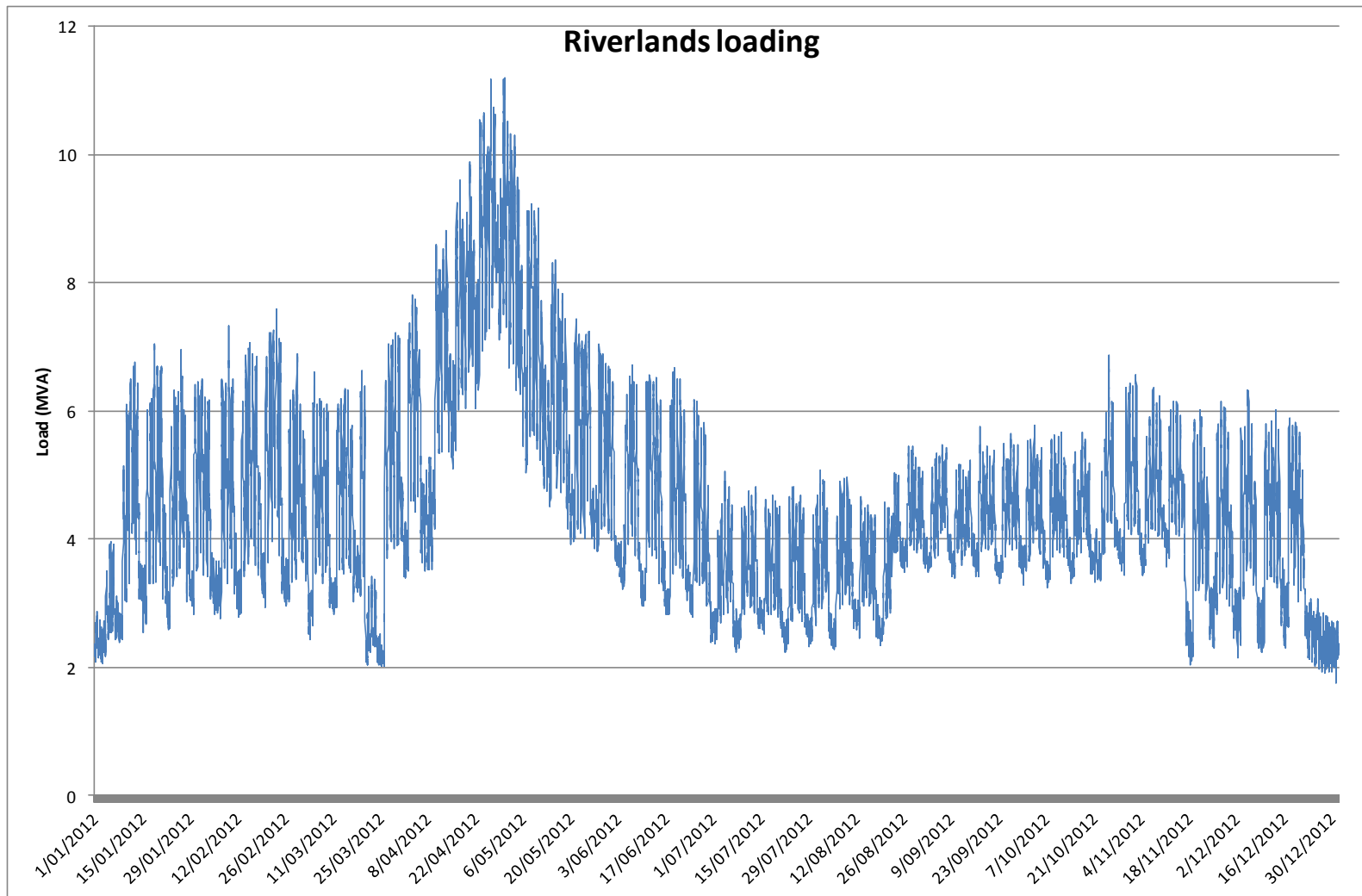

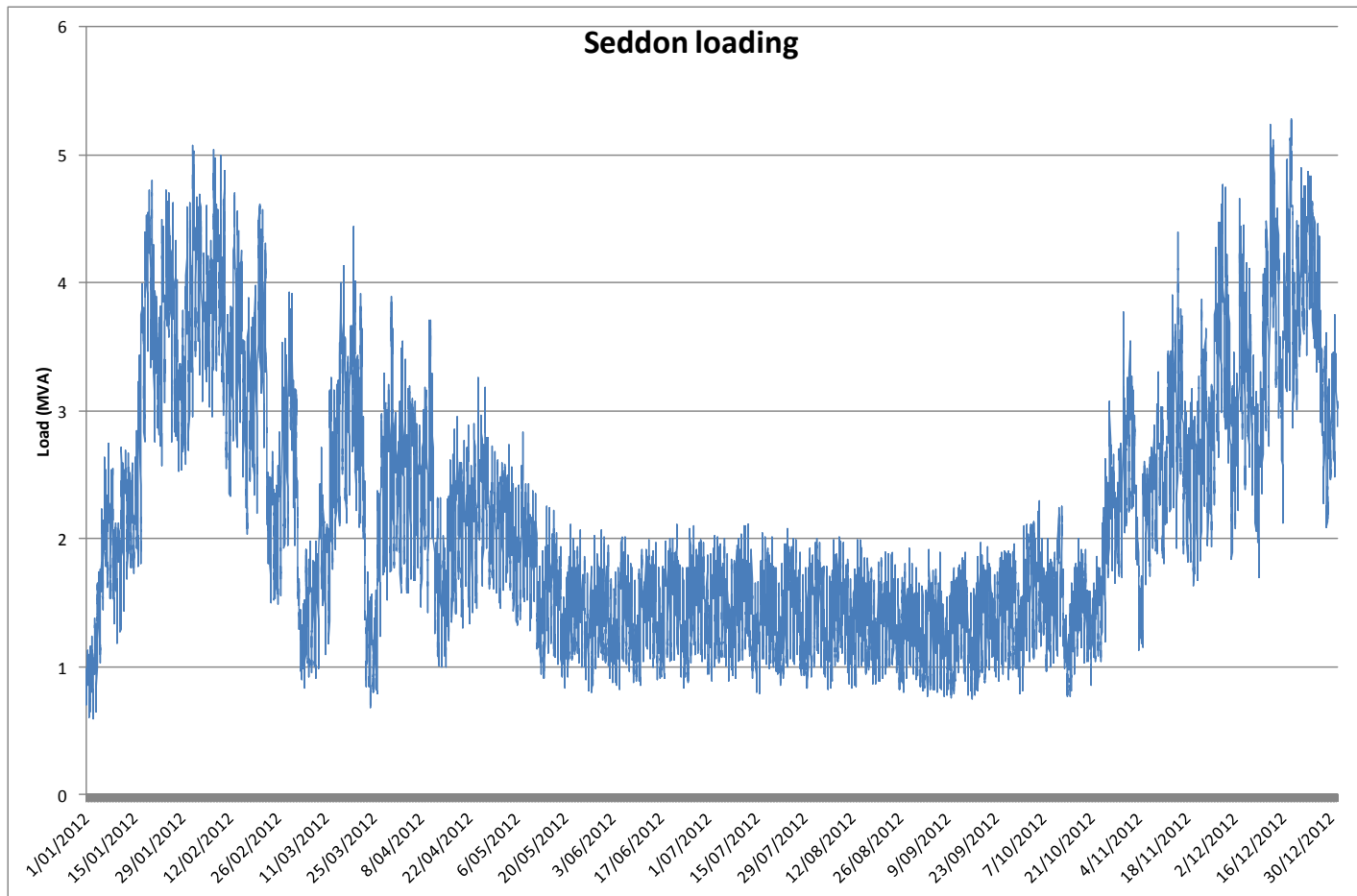

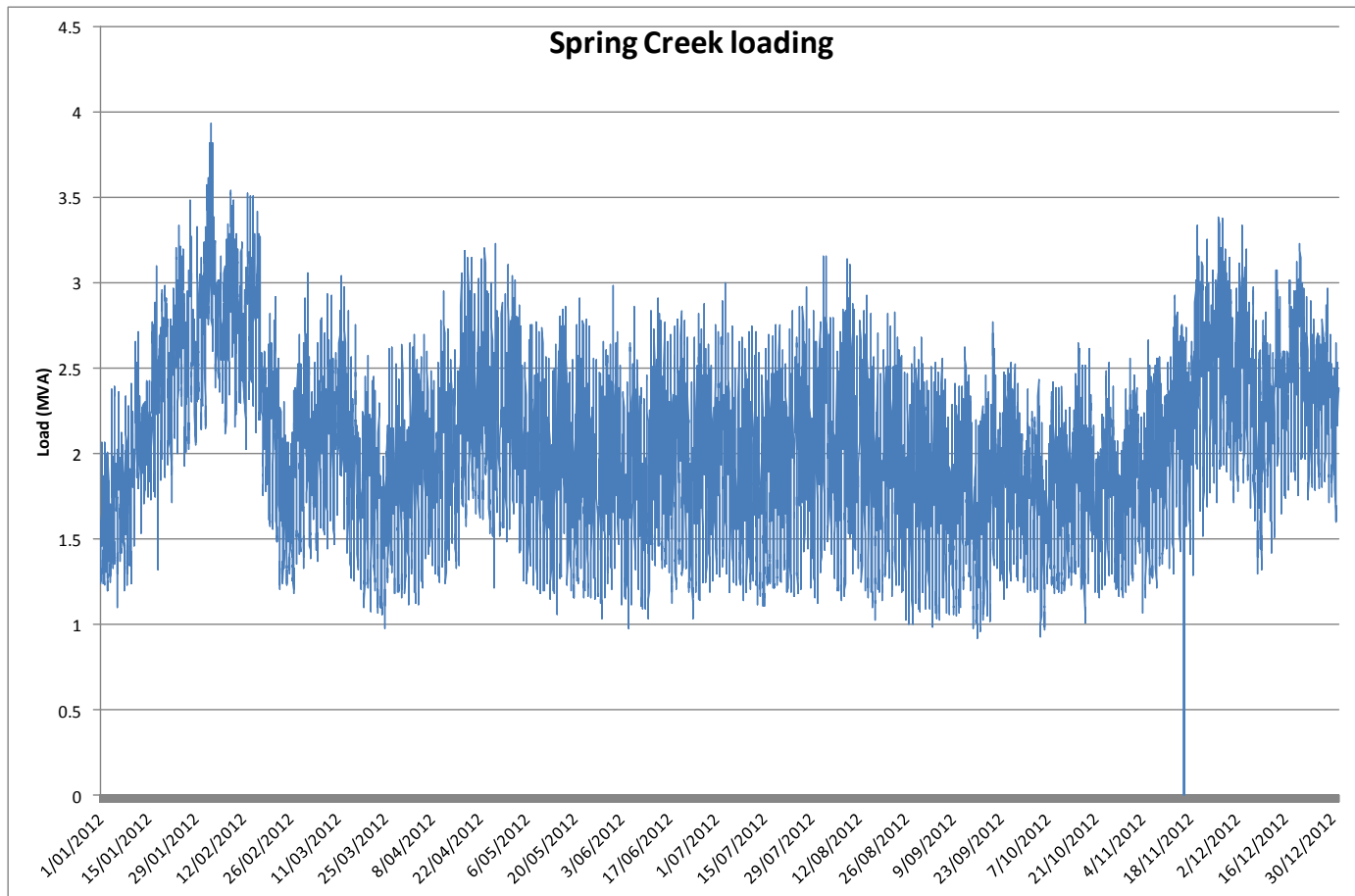

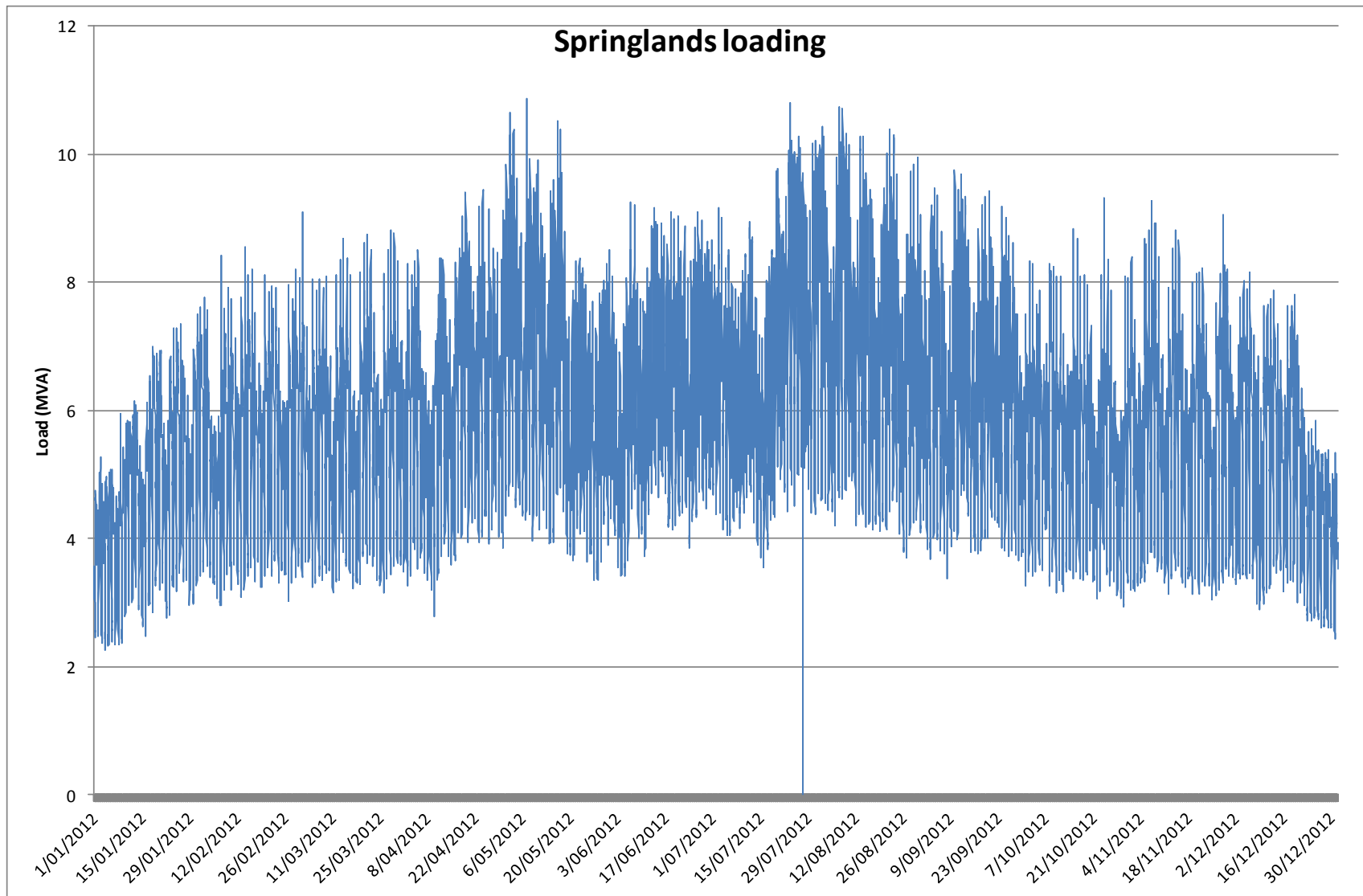



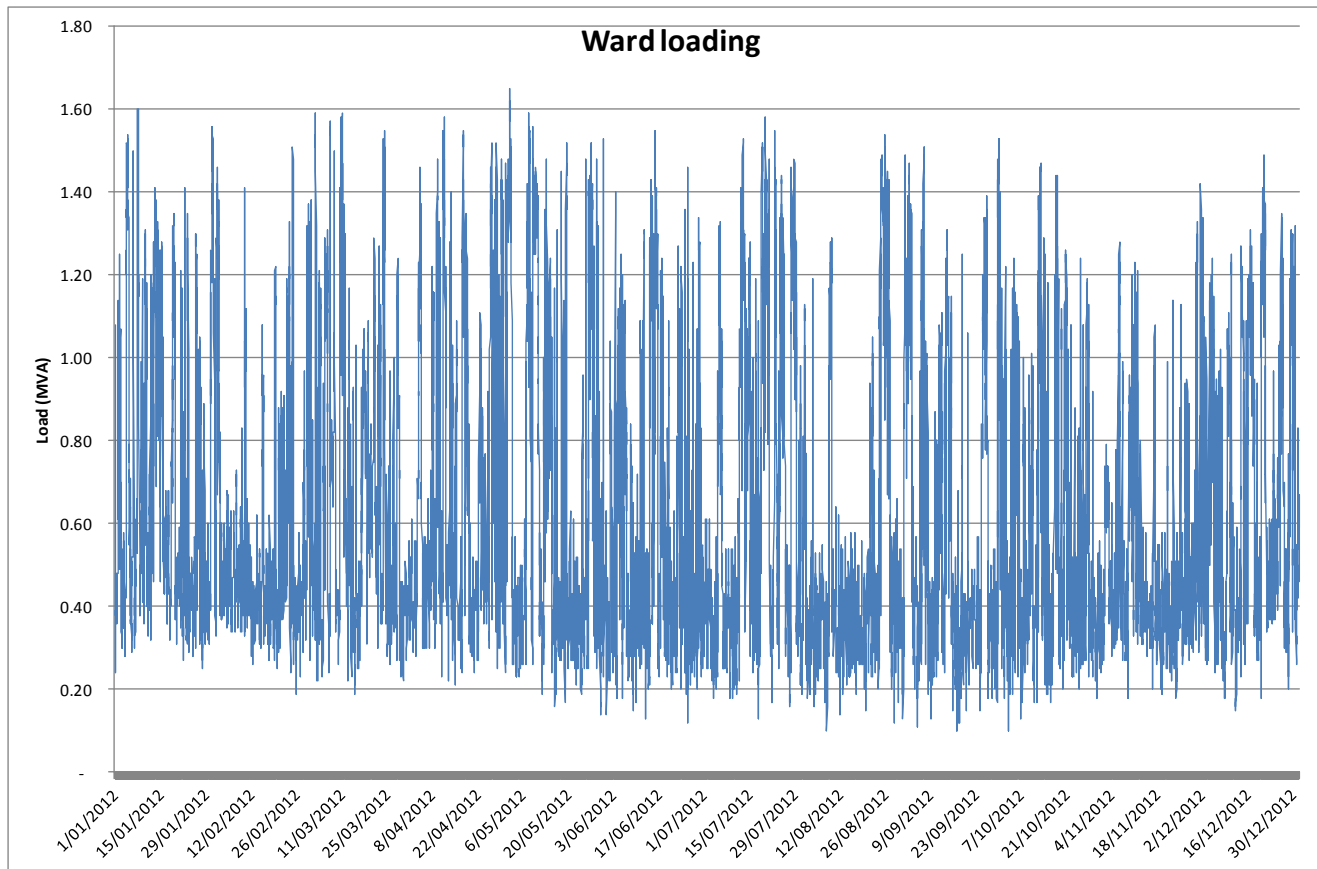

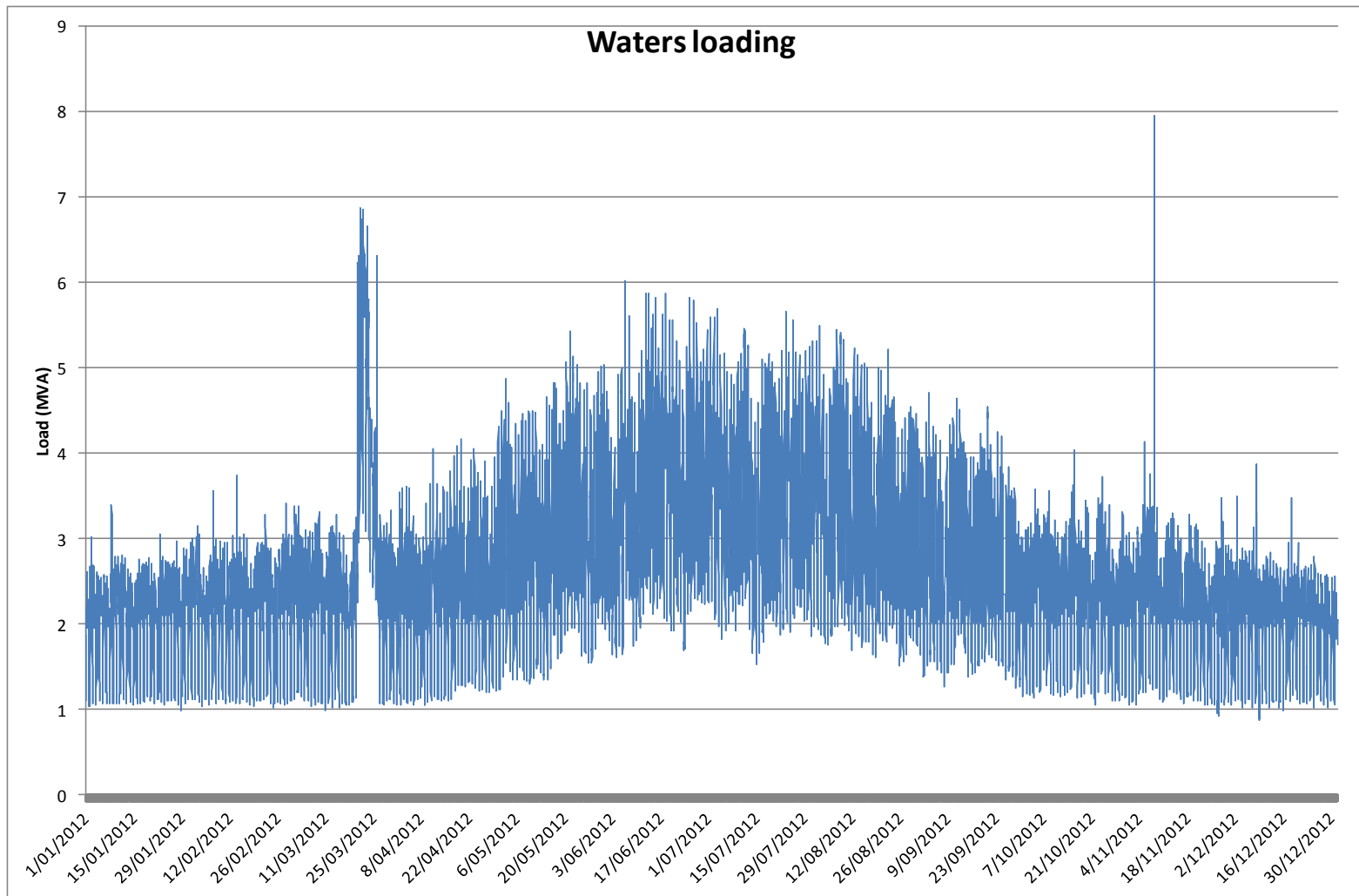

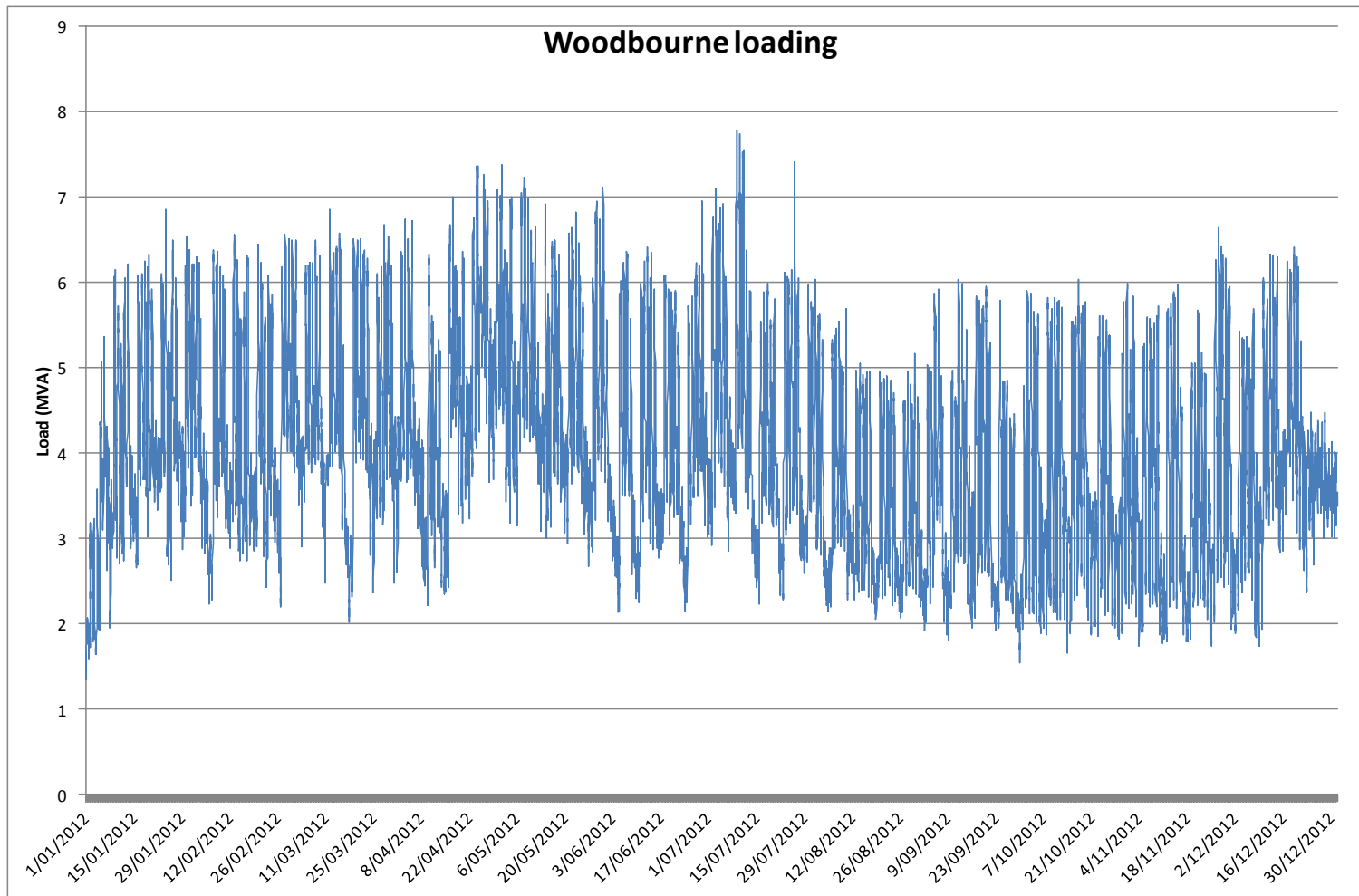

## E General Network Policies

### E.1 Non-asset Solutions

The most appropriate solution for a given problem depends on a variety of factors e.g. cost, benefits, risks and technical appropriateness. In determining whether a non-asset solution is the best option, it is necessary to consider its use in terms of how it relates to our overall objective of operating as a successful business. In general, non-asset solutions are the preferred option where they:

- Are lower than overall cost or provide a better return than the best asset based solution; and
- Provide similar functionality to the asset based solution.

For example, the Kenepuru feeder from Linkwater substation supplies some 1084 installations of which many are baches with only occasional occupancy. The 11kV feeder is generally lightly loaded, except for a few days each year when the baches are occupied. In the event of substantial development in this area, there are a number of possible solutions.

The asset based solution is to upgrade part of the main line to 33 kV and install a small package zone substation in the Kenepuru area. There are some substantial costs associated with such a proposal. A possible non-asset solution is to provide each installation with ripple control on its water-heater (traditionally this has not been provided) and create a special channel for this area. This could provide substantial relief as the major loadings occur when bach owners all arrive at the beginning of holiday periods and turn on the heater, the water heater, and cook at the same time. This is common at the beginning of the Easter period. The use of a 'Kenepuru' ripple channel would allow deferment of the capital required for a full upgrade, and as such is likely to be a viable non-asset solution.

The implementation of the new 217Hz ripple injection plant is allowing shedding of controllable load by areas. This, together with the solution proposed above will reduce some of the MD constraints.

Non-asset options broadly fit into two classes:

#### *E.1.1 True Non-asset Solutions*

This class of solutions aims to avoid or defer demand growth through the following means:

- Adopting tariff structures that signal costs to consumers, such as time periods or undesirable asset configurations (e.g. large motors without power factor correction). This can be difficult to implement because retailers may distort pricing information by repackaging line tariffs.
- Using load control to reduce peak demand. Current demand on cold mornings and evenings can exhaust all controllable hot water load. A combination of increasing use of load control combined with an increasing amount of load with little contribution to winter loadings (e.g. wine/dairy industry) has seen the system's maximum demand remain relatively

unchanged for the last few years, despite large increases in installed capacity and substation maximum demands.

- Promoting conservation and efficiency incentives. MLL has a consumer advisory service which advises consumers on energy efficiency e.g. house insulation, hot water temperature settings etc.

#### *E.1.2 Partial Non-asset Solutions*

This class of solutions aims to accommodate demand growth principally through increasing the rating of existing assets, e.g.:

- Installing forced cooling on ONAN transformers.
- Installing additional instrumentation so that assets can be more closely monitored and hence operated closer to maximum ratings.
- Recognising that older equipment often included generous design margins that can be exploited.

## **E.2 Distributed Generation**

MLL recognises that distributed generation potentially provides value in the following ways:

- Reduction of peak demand at Transpower GXP's, with subsequent savings of upstream investment (including generation).
- Reducing the effect of existing network constraints.
- Avoiding investment in additional network capacity.
- Making better use of local primary energy resources thereby avoiding line losses.
- Avoiding the environmental impacts associated with large scale power generation.

However MLL also recognises that distributed generation can have the following undesirable effects:

- Increased fault levels, requiring protection and switchgear upgrades.
- Increased line losses if surplus energy is exported through a network constraint.
- Stranding of assets, or part of an asset's capacity.
- Altering power flows which requires re-setting and recalibration of protection and controls.
- Adding very large point injections at lightly loaded points on the network.

MLL encourages the development of distributed generation that will benefit both the generator and Marlborough. MLL does however note that the requirement to pass avoided transmission costs derived from distributed generation through to connected users is a major disincentive for distributed generation i.e. MLL incurs costs but cannot capture a margin on the benefits arising from those costs.

For further information on the connection of Distributed Generation, please see the Distributed Generation information on our website <http://www.marlboroughlines.co.nz>

### **E.3 Redeployment of Existing Assets**

Assets that are removed from service may be redeployed where it is economic to do so and at least a further 20 years of life is possible. MLL routinely redeploys transformers and switchgear in this manner after they have been refurbished. Thorough inspection, testing and maintenance must be undertaken on all such equipment. The standards required for equipment to be connected to the Network are maintained within MLL' ISO 9001:2000 quality assurance system and the Network standards. Contractors may only install second-hand equipment with specific approval from Network and should provide a minimum of a 10-year guarantee that the equipment is fit for purpose and free from defects.

Assets that are removed from service because they are uneconomic will not generally be redeployed. Assets removed from service because they are unsafe will not be redeployed nor will they be on-sold for further use.

### **E.4 Upgrade of Existing Assets**

MLL requires all upgrades of existing assets to meet approved investment criteria, the principal criteria being that an appropriate commercial return can be achieved for the capital deployed.

If the cost of capital cannot be recovered, there must be other compelling reasons for the upgrade such as public safety or regulatory compliance.

### **E.5 Installation of New Assets**

All extensions or enhancements to the MLL' Network are required to meet approved investment criteria, the principal criteria being that an appropriate commercial return can be achieved.

Where a new extension to the MLL' Network or an enhanced supply is requested by a consumer, then the consumer requesting the extension or enhancement is responsible for the costs of installing the new assets.

MLL may contribute to that investment subject to the following conditions:

- An economic assessment of the likely additional line revenue must demonstrate that MLL's cost of capital can be met.
- The extension or enhancement is built to MLL's technical and engineering standards.
- The extension or enhancement will vest in MLL and the vestor will cease to have any interest in the extension or enhancement. In particular, MLL may connect other consumers to the extension or enhancement at its sole discretion.
- Any necessary easements are completed on MLL' s standard terms and conditions.

## **E.6 Adoption of New Technology**

Unproven Technology will not be used in any location where its reliability might adversely impact on the reliability of supply or reduce safety. The Network will not be used as a test area for unproven technologies.

MLL keeps a close watch on new technologies and best industry practice by reviewing technical publications, membership of industry groups and by active participation in industry initiatives. Where new technologies or work practices, including asset management techniques, can improve operational efficiency, increase performance, reduce costs, improve safety or otherwise provide benefits to MLL or its stakeholders, they will be thoroughly investigated and, if appropriate, adopted.

## **E.7 Disposal of Existing Assets**

MLL reviews the cost benefit of maintenance, environmental effects, safety, reliability and operational improvements before deciding to dismantle, dispose or replace existing assets. Any disposal of materials such as oil or lead will be undertaken by suitably accredited contractors.

## **E.8 Safety**

MLL is committed to providing a safe environment for staff, customers and the public. Minimum standards are set by the relevant legislation: the Electricity Act 1992, the Electricity Regulations 2003, the Health and Safety in Employment Act 1992 and the Health and Safety in Employment regulations 1995.

One key area within the ISO 9001:2000 and ISO 14001:1996 quality and environment systems, is safety. Procedures have been developed to cover hazard management, fire evacuation, oil spill, accidents, and earthquakes. Operational procedures cover additional areas such as Hiab and EPV operation, construction blasting, traffic management and ladder testing.

MLL has been recognised by the Department of Labour as successfully implementing all of the management systems promoted in the Department's Achiever programme. In addition, MLL has now achieved Tertiary level status for the ACC Work Place Safety Management Practices program.

MLL has systems in place to ensure all persons undertaking work on Network assets have appropriate qualifications, training and experience for the work being undertaken. Authorisation Holders Certificates document each person's competencies. All practical steps are taken to provide all employees and all contractors' employees with good, safe working conditions.

## **E.9 Tangata Whenua**

MLL is committed to Te Tiriti o Waitangi/Treaty of Waitangi and recognises the unique role of tangata whenua as kaitiaki of the country's natural environment. Where appropriate, consultation will be held on any matters that affect Maori. In particular MLL recognises the need for consultation on Wahi Tapu sites or areas. MLL has an accidental discovery protocol and recognises the need to safeguard NZ's archaeological sites.

MLL has an ongoing relationship with Marlborough Iwi.

## E.10 Easements

To protect the viability of the Network, easements are required in the following circumstances:

- **Relocation of existing assets:** Where a landowner requests that a line or other asset owned by MLL that supplies other customers or crosses other owners property is moved, an easement, of acceptable form to and in favour of MLL is required prior to relocation of the line.
- **New Assets where ownership is to be transferred to MLL:** Where ownership of new assets is to be transferred to MLL, an easement of acceptable form to, and in favour of, MLL is required.

Easements are recommended, but not mandatory where the assets are:

- of the voltage at which the consumer takes supply (generally 230/400V); and
- supply a single installation only; and
- are entirely located on a single title; and
- the landowner is the person responsible for their construction.

Easements must be provided before any future installation can be connected.

MLL monitors subdivision resource consent applications and recommends easements as part of the subdivision. This policy reduces the cost of establishing electricity supply, but does impose some risk on future landowners. Should subdivision occur without easements, it is possible that a future person may require the assets to be removed, thereby removing supply.

**New Subdivisions:** Whenever practical any transformer required to supply the subdivision is installed on a small section that is converted to legal road as part of the subdivision completion. Whenever Network assets are to be located on private land, easements for these are obtained at the developer's cost as part of the final survey of the subdivision.

Where required, easements must be surveyed, signed, and ready for registration before connection to the Network will be allowed.

## E.11 Capital Repayments

Where customers wish to connect to recently constructed assets, and where those assets were funded in part or whole by the existing customers, capital repayments to the original customers are due. These vary according to the value of the original works, and the percentage of the original work being used by the new connection. Repayments will be made for up to five years after construction.

The value of the original works is determined by using the ODV handbook published by the Commerce Commission. Repayments are based on the number of parties sharing the assets. A new connection is charged an equal share of the value of the assets and this is distributed to the parties with an interest in the assets.



## **E.12 Sounds Contribution**

As a result of past Government policies and legislation, MLL and its predecessors, Marlborough Electric and the Marlborough Electric Power Board have contributed considerable amounts of capital to establishing and maintaining supply into the Marlborough Sounds. In order to provide MLL with a small return on the capital put into this area, all new connections must pay a connection fee to MLL. In addition to this fee, some new connections require capital repayments to the customers who originally contributed to the cost of installing the works.

## **E.13 Network Enhancement Contribution**

A contribution to the cost of providing the Network may be charged for new connections. The contribution is based on the area, the distance from the 33/11kV substation and the connected capacity.

## **E.14 Mobile Generators**

Marlborough Lines has a number of mobile generators available to reduce interruptions in the Network. At its sole discretion MLL will use mobile generators to provide supply where:

- More than 20 customers can be supplied
- One or more group 4 customer can be supplied
- For hospitals, schools and or/rest homes.

Provided that the load is sufficient to load the generator to more than 15% of its rating and the interruption is 2 hours or longer.

Aside from customers identified above, generators will not be generally supplied to individual customers. Where Marlborough Lines are undertaking work as part of a shutdown, Marlborough Lines will connect and disconnect customer supplied generators, subject to reasonable notice and sufficient information and access being provided.

## **E.15 Live Line Work**

Live Line work assists in reducing interruptions of supply. Within the Network, Live Line techniques have been utilised for:

- Line taps for spur lines and/or transformer connections
- Cross-arm changes
- Bird-spike installation
- Air break switch changing
- Pole changing
- Insulator changing
- Hardware tightening
- Tree cutting

In general, Live Line techniques are more costly than conventional shutdowns, if the costs of non-supply to customers are ignored. MLL uses Live Lines techniques when:

- It is practical and safe to do so (i.e. earth blocks are available and appropriate procedures exist); and
- Costs are less than for a conventional shutdown; or
- More than 100 customer hours would be lost during a shutdown; or
- Major customers would be shutdown.
- It is not practical to use mobile generators.

## **E.16 Maintenance**

Maintenance is undertaken in order to preserve the function of existing assets. When considering maintenance, aspects including safety, capacity, security of supply and reliability are considered. Reviews of the condition assessment information, coupled with fault and reliability data enable maintenance to be directed into areas where maximum benefit can be gained. MLL recognises the legislative requirement to maintain all existing supplies, and appropriate levels of maintenance are provided.

## **E.17 Line Charges**

The current line charging structure is ICP based, under Interposed Use of System Agreements with retailers. With this structure of charges, retailers are billed line charges for individual ICPs connected to the Network.

## **E.18 Access on to Private Property**

MLL's Network has many kilometres of line located on private property. Where the lines were constructed before 1993, MLL is authorised by the Electricity Act 1992 to enter the property to undertake maintenance. Where lines have been constructed after 1993, easements are essential to protect the ability of MLL to provide supply to customers further down the line.

Existing lines can only be upgraded with the consent of the landowner or if the land is not affected. Unfortunately if this is not possible, it may lead to the Network being unable to maintain good supplies and/or accept further expansion in outlying areas.

At all times, MLL is aware of the need to take care when entering private property, to protect the landowner's rights to use and enjoy their properties.

## **E.19 Access to Network**

Retailer Access to the Network is provided via a Use of System Agreement. This is available to any Retailer.

Access for work is available to contractors who hold Authorised Holder Certification for MLL Network. This essentially requires that the contractor is appropriately qualified, has competent staff and appropriate safety systems. Further details on the Authorised Holder Certification system are available from the Operation Manager. Approval is required prior to any work being commenced and notification of all completed works must be given.

## **E.20 22kV Construction**

With the increasing loads in the rural areas and the low marginal cost of using 22kV insulated equipment, the company has introduced a requirement that all new construction to be connected to the 11kV Network in rural areas must be insulated to 22kV levels.

## **E.21 Pole Types**

Due to problems with the quality of timber poles, all new construction must use pre-stressed concrete poles, except where specific conditions exist and approval is obtained from MLL.

## **E.22 Ownership of Assets**

For the ownership and therefore maintenance responsibilities for any new assets to be transferred to MLL, the following must occur:

- The assets must be constructed of suitable materials and in accordance with good industry practice; and
- Easements must be established if required; and
- The contractor must warrant that the work is free from defects and provide suitable guarantees to repair any defects arising from poor workmanship or sub-standard materials that occur within the first ten years after construction.

## **E.23 Overhead or Underground Construction**

Overhead construction is much lower cost than underground construction (typically 1/6 to 1/3 of the cost of underground). Overhead lines tend to have higher maintenance costs, although faults in an underground system can be difficult to locate and expensive to repair. Marlborough District Council District planning requirements require all new construction in the urban areas to be underground. Elsewhere, overhead construction is preferred because of the lower costs.

Most of the central business district in Blenheim, Picton, Renwick and Havelock is reticulated by way of underground cabling. The Company, in conjunction with the Marlborough District Council has converted most of the reticulation on the main roads leading into Blenheim to underground.

Further underground conversions will only be undertaken in areas where the Territorial Authorities require the overhead reticulation to be removed and costs are met. The value restrictions of the ODV valuation criteria are such that the full cost of underground reticulation cannot be included in the ODV. Until this unsatisfactory situation is addressed, further overhead to underground reticulation will not be undertaken.

## **E.24 Stores**

The items held in stock in the MLL Store include, emergency spares for the Network, stock for work due to proceed, and stock for contracting purposes. Items that do not fall into one of these categories are not required to be maintained in the Store and will be scrapped or sold as appropriate.

Operation of the Store adheres to the ISO 9001:2000 quality assurance system. Procedures are in place to control the way products are purchased and stored. The stock is comprehensive and stored in purpose-built, alarmed, secure buildings. The total inventory is recorded within MLL's accounting computer system. This includes programs for purchase, storage and issue of goods, and gives real-time indication of stock status. The system provides for stock-out notification to ensure that products are replaced as needed and to ensure that adequate emergency stock levels are maintained.

Where appropriate, backup supply of some items has been arranged with key suppliers. For example, concrete poles are held both in our own storage area and with the local manufacturer. The Store is manned during normal working hours and emergency staff have access outside these hours.

Most items contained in the Store stock are laid out in sequential bays with descriptions on each bin and computer inventory numbers. Details such as suppliers and stock movements are recorded in a database to allow quick access to information on the various components used within the Network.

## **E.25 Fault Service**

MLL operates a 365 day, 24 hr a day fault service. Repairs to Network equipment are carried out at no cost to affected customers. Where any person damages Network equipment, the full cost of repair will be sought from the person causing the damage. Where repairs are required within the customer's installation, all work is chargeable to the customer.

# F Single Line Diagrams

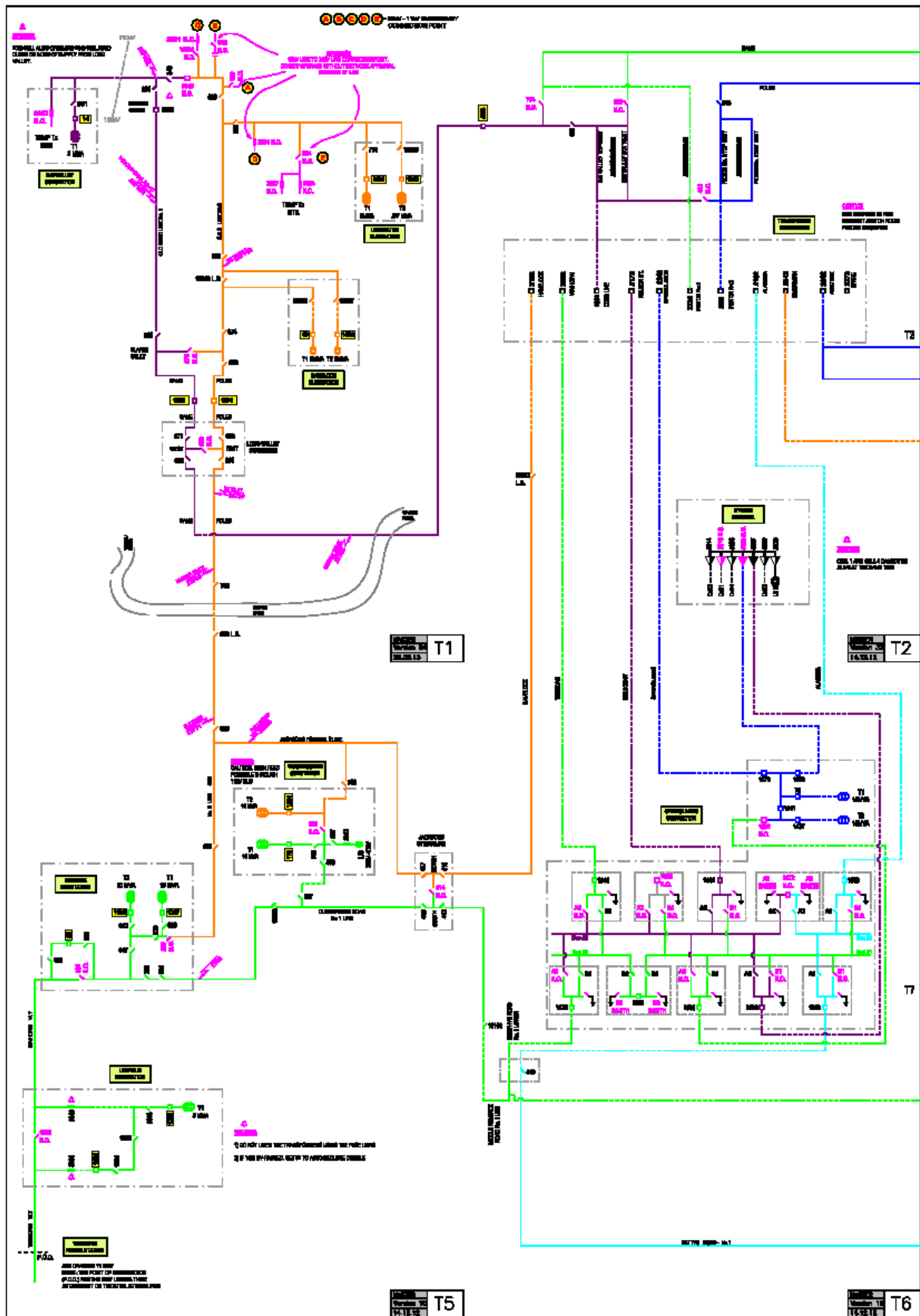



## G Liquefaction and Tsunami Zones

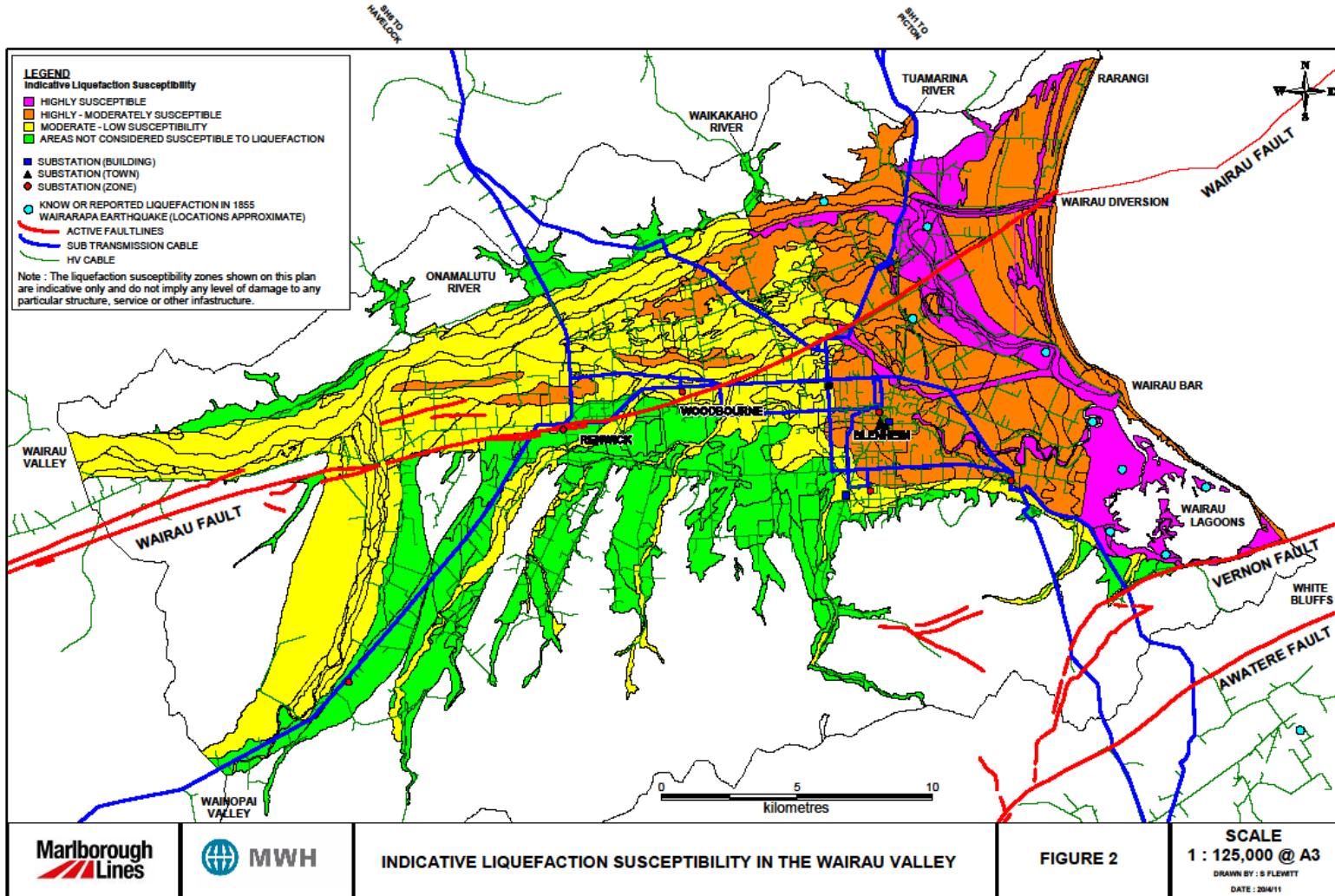

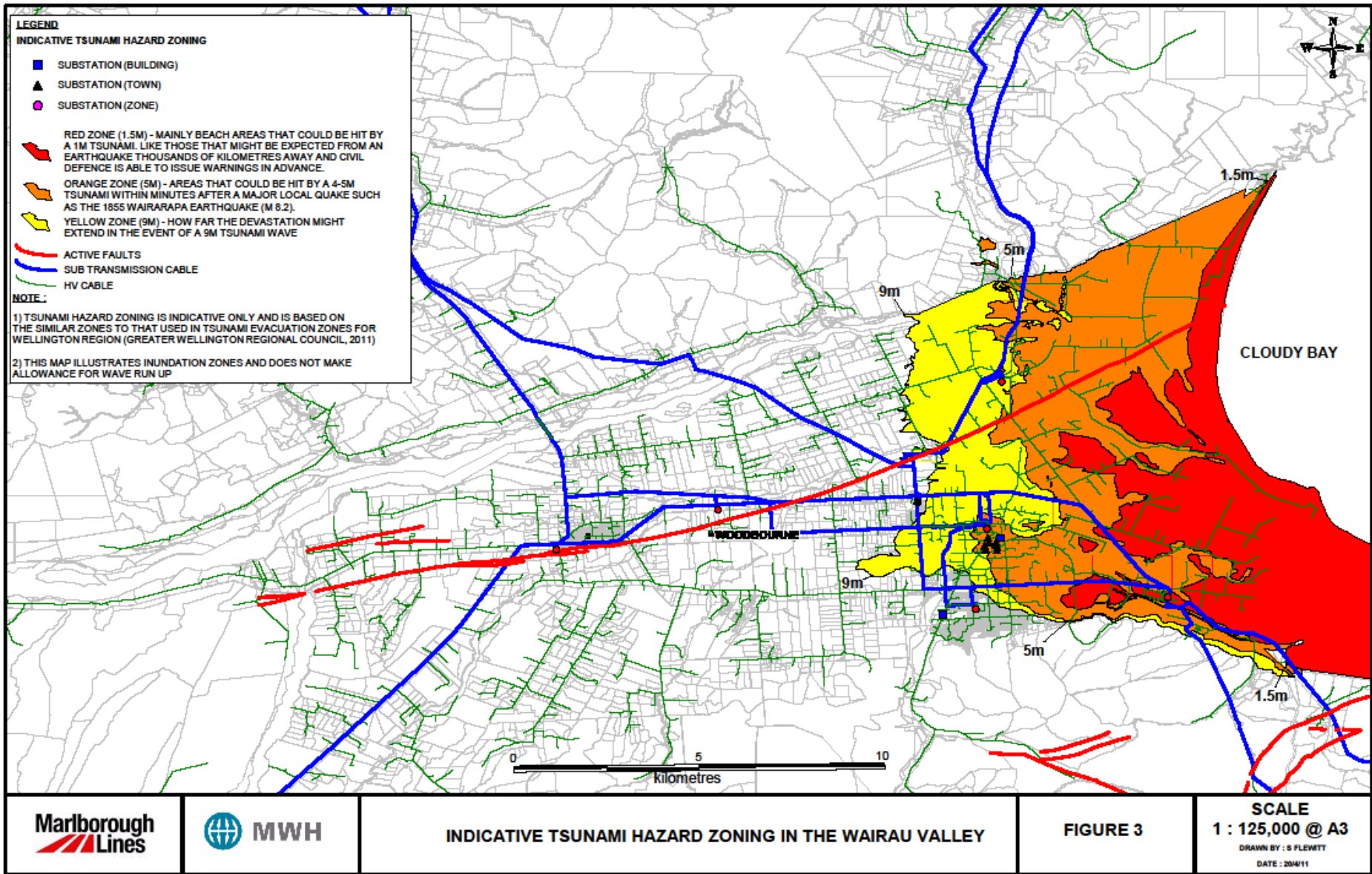



## H Glossary of Terms

|   |  |
|---|--|
| <b>AAAC</b>   | All aluminium alloy conductor.   |
| <b>ABS</b>  | Air Break Switch – used in the 33kV and 11kV Networks.   |
| <b>ACR</b>  | Asset Critically, a measure of important of asset for providing service.   |
| <b>AMP</b>  | Asset Management Plan.   |
| <b>GAAP</b>   | Generally Accepted Accounting Principles.  |
| <b>GIS</b>  | Geographic Information System – a way of storing information in a computer such that the location of the equipment is also stored and various maps/views can be produced.  |
| <b>GPS</b>  | Global Positioning System. Receivers utilise satellites to accurately locate themselves on the earth’s surface. This information is then used to locate items such as power poles.   |
| <b>CAIDI</b>  | <p>For the Total of All Interruptions (Customer Average Interruption Duration Index).</p> <p>CAIDI is the average duration of an interruption of supply for consumers who experienced an interruption of supply in the period. The CAIDI for the total of all interruptions is the sum obtained by adding together the interruption duration factors for all interruptions <i>divided by</i> the sum obtained by adding together the number of electricity consumers affected by each of those interruptions.</p> $\text{CAIDI} = \frac{\text{Sum of [No. of Interrupted Consumers x Interruption Duration]}}{\text{Sum of [No. of Interrupted Consumers]}}$ <p style="text-align: center;"><i>in minutes/consumer interrupted</i></p> |
| <b>CDMA</b>   | Data system provided by Telecom, uses Cell Network, MLL uses this for some SCADA communications.   |
| <b>DOC</b>  | Department of Conservation.  |
| <b>EPV</b>  | Elevating Platform Vehicle – Used in Live Line work and for ease of maintenance on various assets.   |
| <b>GFC</b>  | Global Financial Crisis.   |
| <b>GXP</b>  | Grid Exit Point, connection between Distribution Network and National Grid.  |
| <b>Hiab</b>   | Trade Name for truck mounted hydraulic crane.  |
| <b>kVA</b>  | 10 <sup>3</sup> VA. Measure of apparent power.   |
| <b>kWh</b>  | 10 <sup>3</sup> Wh measure of energy.  |
| <b>Live Line</b>  | Various techniques for working on the Network with the power on. Procedures range from connection of transformers to complete pole replacement.  |
| <b>MapInfo.</b>   | GIS software currently used by MLL.  |
| <b>MDC</b>  | Marlborough District Council.  |
| <b>MLL</b>  | Marlborough Lines Limited.   |
| <b>MVA</b>  | <p>10<sup>6</sup> VA. Measure of apparent power.</p> <p>N level security, any one failure causes loss of supply.</p> <p>N-1 level security, two failures required before loss of supply.</p>   |
| <b>Number of Faults per 100km of Prescribed Voltage</b> | This is a measure of the number of faults in relation to the total length of the network 6.6kV and above. Lower frequency for line related faults, than for a similar line business, would suggest more effective line maintenance, though a very low figure   |

|                       |  |
|-----------------------|--|
| <b>Line</b>           | could indicate over investment.  |
| <b>NZTA</b>           | New Zealand Transport Agency.  |
| <b>ODV</b>            | Optimised Deprival Value, a method of valuing assets laid down in regulations.   |
| <b>PSTN</b>           | Public Switched Telephone Network, i.e. standard telephone system.   |
| <b>Ripple Control</b> | System which uses frequencies >50Hz to transmit information across power system. Mainly used to control water heating/night store loads and street lighting.   |
| <b>SAIDI</b>          | <p>For Total of Interruptions (System Average Interruption Duration Index).</p> <p>SAIDI is the average total duration of interruptions of supply that a customer experiences in the period. The SAIDI for the total of interruptions is the sum obtained by adding together the interruption duration factors for all interruptions <i>divided by</i> the total customers.</p> <p>SAIDI = <math display="block">\frac{\text{Sum of [No. of Interrupted Consumers x Interruption Duration]}}{\text{Total Number of Connected Consumers}}</math><br/><i>in minutes/connected consumer/year</i></p>              |
| <b>SAIFI</b>          | <p>For the Total Number of Interruptions (System Average Interruption Frequency Index).</p> <p>SAIFI is the average number of interruptions of supply that a consumer experiences in the period. The SAIFI for the total number of interruptions is the sum obtained by adding together the number of electricity consumers affected by each of those interruptions <i>divided by</i> the total consumers.</p> <p>SAIFI = <math display="block">\frac{\text{Sum of [No. of Interrupted Consumers]}}{\text{Total Number of Connected Consumers}}</math><br/><i>in interruptions/connected consumer/year</i></p> |
| <b>SCADA</b>          | Supervisory Control and Data Acquisition, computer and communications system to monitor and control equipment in the Network, e.g. circuit breakers.   |
| <b>SCI</b>            | Statement of Corporate Intent. Standard NZ Voltages, 230V/400V. Transformers output 240V/415V to allow for voltage reduction along lines/cables.   |
| <b>SWER</b>           | Single Wire Earth Return. A system which uses a single wire (compared with two for convectional single phase or three for three phase) to transmit power. MLL uses this system at 11 kV.   |
| <b>TCR</b>            | Task Critically, a measure how urgently maintenance or repair is required.   |
| <b>Thermovision</b>   | Using infra-red technologies to locate hot spots/faults in Network Assets.   |
| <b>VHF</b>            | Very High Frequency, radio frequency used by MLL primarily for voice communications.   |
| <b>WASP</b>           | Asset management and works management software from EMS Solutions Ltd.   |

## I Reader Survey Form

We hope that you have found this document useful and informative. To assist us in refining the document or in reviewing our asset management practices we would welcome your feedback. Please complete any relevant sections of the form below and return it to us:

|                                |  |
|--------------------------------|--|
| <b>Name</b>                    |  |
| <b>Company (if applicable)</b> |  |
| <b>Address</b>                 |  |
| <b>Phone</b>                   |  |
| <b>Fax</b>                     |  |
| <b>Email</b>                   |  |

### Suggestions for improving the report

|  |
|--|
|  |
|--|

### Suggestions for improving our asset management practices

|  |
|--|
|  |
|--|

**CERTIFICATION FOR YEAR-BEGINNING DISCLOSURES**

**Pursuant to Schedule 17**

We, David William Richard Dew and Kenneth John Forrest, being directors of Marlborough Lines Limited certify that, having made all reasonable enquiry, to the best of our knowledge:

- (a) The attached Asset Management Plan of Marlborough Lines Limited prepared for the purposes of clause 2.4.1, clause 2.6.1 and subclauses 2.6.3(4) and 2.6.5(3) of the Commerce Commission's Electricity Distribution Information Disclosure Determination 2012 complies with those determinations.
- (b) The prospective financial or non-financial information included in the attached information has been measured on a basis consistent with regulatory requirements or recognised industry standards.

Signed by:

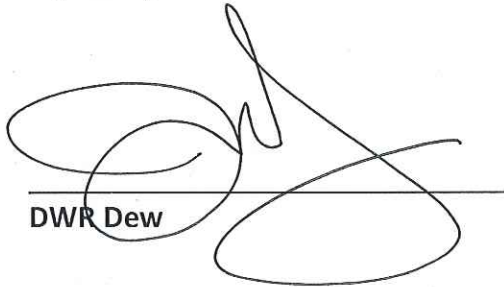

DWR Dew

31/03/15

---

Date

KJ Forrest

---

KJ Forrest

31 March 2015

Date